

THE UNIVERSITY OF HULL

OFFSHORE MARINE VISUALIZATION

being a Thesis submitted for the Degree of Doctor of Philosophy
in the University of Hull

By
Paul M. Chapman, MSc

DECEMBER 2003

*This thesis is dedicated to my Father
Michael R. Chapman.*

Table of Contents

Table of Contents	iii
List of Figures	viii
Abstract	xiii
Acknowledgements	xiv
Relevant Publications	xvi
1 Introduction	1
1.1 Aim and Objectives of Thesis	3
1.2 Thesis Outline	4
2 Offshore Industry and Sonar Review	6
2.1 Shipwreck Inspection	6
2.2 Pipeline Inspection	7
2.3 Route Survey	8
2.4 Dredging Surveys	8
2.5 Debris Search and Recovery	8
2.6 Marine Data Acquisition Methods	9
2.6.1 Earth Orbiting Satellites	9
2.6.2 Photography and Video Footage	10
2.6.3 Airborne Lidar Bathymetry	11
2.6.4 Sonar Technology	12
2.7 Evaluation of Acquisition Techniques	23
3 Visualization	25
3.1 Visualization Reference Models	26
3.1.1 Upson et al's Reference Model	26
3.1.2 Haber and McNabb's Reference Model	27
3.1.3 User Feedback	28
3.2 Categorising Visualization Systems	29
3.2.1 Turnkey Visualization Systems	29

3.2.2	Modular Visualization Environments	29
3.3	Summary	30
4	Seabed Visualization Systems Review	32
4.1	Essential and Desirable Requirements for an Offshore Marine Visualization System	32
4.1.1	3D Rendering	33
4.1.2	Visualization and Interaction with Multiple Datasets	33
4.1.3	Real-time 3D Visualization of Offshore Activities	33
4.1.4	System Flexibility	34
4.2	Review of Contemporary Marine Visualization Techniques	34
4.2.1	Generic Visualization Software	35
4.2.2	Geographical Information Systems	39
4.2.3	Purpose Built Turnkey Marine Visualization Systems	42
4.2.4	Custom Built Marine Visualization Systems - DIY	48
4.3	Evaluation of Contemporary Marine Visualization Systems	51
4.4	Proposed Marine Visualization System	52
4.4.1	Post-survey 3D Visualization of Bathymetric Sonar Data	52
4.4.2	Mapping Computer Generated Objects onto Sonar Data	53
4.4.3	Geometrical Reduction of Models for Rendering Efficiency	53
4.4.4	Encapsulation of Multiple Datasets Relating to a Single Survey	53
4.4.5	Proof of Concept of Real-time 3D Marine Visualization	54
4.4.6	Visualization of Complex Offshore Environments with Multiple Real-time Data Streams	54
4.4.7	Real-time High Resolution Sonar per-ping Visualization in 3D	54
5	WFM System Architecture	56
5.1	WFM Hardware Implementation	56
5.1.1	Graphics Processor Technology	57
5.2	WFM Software Development	57
5.3	WFM Visualization Pipeline	58
5.3.1	Extending the Model	61
5.4	Summary	63
5.4.1	WFM Case Studies	63
6	Shipwreck Visualization	69
6.1	Introduction	70
6.2	The Survey	71
6.3	Traditional Shipwreck Data Acquisition and Visualization Methods	71
6.4	Shipwreck Visualization Architecture	74
6.5	Results	75
6.5.1	Visualization of ϵ_2^s Bathymetric Data	75
6.5.2	Integration of Computer Generated 3D Models with Sonar Data	76
6.5.3	Areas of Interest (AOIs) and Levels of Detail (LODs)	76

6.5.4	Realistic Underwater Rendering	80
6.5.5	User Interaction	81
6.6	Summary	81
7	Harbour Wall Visualization	83
7.1	Introduction	83
7.2	Harbour Model Construction	84
7.3	Architecture	85
7.4	Results	85
7.4.1	Extend WFM's Architecture for the Visualization of ϵ_3^p Sonar Data.	87
7.4.2	Consider how multiple computer generated 3D models can be integrated and overlaid with sonar data.	87
7.5	Summary	88
8	Pipeline Visualization	91
8.1	Introduction	93
8.2	Traditional Visualization Methods	94
8.3	Pipeline and Peripheral Seabed Data Acquisition	94
8.4	Post-survey Pipeline Visualization	98
8.4.1	3D Pipeline Model Generation	98
8.4.2	Post-survey Summary and Results	99
8.4.3	Model Validation	102
8.4.4	Post-survey WFM Architecture	103
8.5	Real-time Pipeline Visualization	105
8.5.1	The Zeebrugge Pipelay Project	106
8.5.2	Real-time Architecture	108
8.5.3	Real-time Summary and Results	110
8.6	Summary	112
9	Real-time Debris Clear-up Visualization	113
9.1	Introduction	114
9.2	The Clear-up Process	115
9.2.1	Clear-up Procedure	117
9.2.2	Complexity of Operations	119
9.3	Implementation	119
9.4	WFM Architecture	122
9.5	Problems Encountered	124
9.6	Results	125
9.6.1	Real-time Modelling of Machinery used in a Complex Debris Clear-up Operation	125
9.6.2	Consider the Real-time Modelling of Underwater Vehicles	126
9.6.3	Psychological Study of Offshore Staff Interfacing to a 3D Graphical Visualization of Complex Offshore Procedures	126
9.7	Summary	130

9.7.1	Architecture Evaluation	131
9.7.2	Real-time modelling of the Kursk Recovery	134
9.7.3	Case Study Evaluation Map Appraisal	137
10	Diamond-mining Visualization	138
10.1	Introduction	139
10.2	The MV Kovambo Diamond Mining Vessel	139
10.3	The Tool	141
10.4	Original Mining System	142
10.5	Proposed Visualization System	143
10.6	Diamond Mining Visualization Architecture	144
10.6.1	ProcessPings Filter Object	144
10.6.2	WFMTTool Mapping Object	144
10.6.3	WFMTerrainD Mapping Object	147
10.7	Results	149
10.7.1	To Consider Real-time per ping Updates to Seabed Terrain	150
10.7.2	Observations of Offshore Staff Interfacing to a 3D Graphical Visualization of the Diamond Mining Process	153
10.7.3	Tool Deployment and Recovery	155
10.8	Summary	155
11	Immersive Marine Visualization - Augmenting the WFM Architecture	158
11.1	Introduction to Immersive Technology	159
11.1.1	Stereo Projection	159
11.1.2	Head Mounted Displays (HMDs)	159
11.1.3	Hemispheric Displays	160
11.2	Current and Proposed Work with Immersive Marine Visualization Systems	161
11.2.1	BP Centre for Visualization	161
11.2.2	Future Immersive Marine Projects: Virtual Great Barrier Reef	162
11.3	The Practicalities of Real-time Immersive Offshore Visualization	163
11.3.1	Vessel 'Real Estate'	163
11.3.2	Stereo Eye Fatigue	164
11.3.3	Relocating the Real-time Marine Displays	165
11.4	Augmenting the WFM View Architecture to Accommodate Stereo and Fish-eye Distortion	166
11.4.1	Generating Stereo Views	166
11.4.2	Generating Fisheye Views	166
11.4.3	Immersive WFM Architecture	168
11.5	Immersive Technologies for Line Monitoring	168
11.5.1	Visualizing Offshore States	170
11.6	Immersive Technologies for Tele-operations	170
11.6.1	Immersive Tele-operations In Practice	171
11.7	Post-survey (non-real-time) Onshore Immersive Displays	171
11.7.1	Post Survey Stereo Pipeline Visualization	173

11.7.2 Post-survey Hemispheric Pipeline Visualization	173
11.8 Summary	174
12 Conclusions and Future Work	177
12.1 Review of Aims and Objectives	177
12.2 WFM Architecture Review	179
12.2.1 Alternatives to WFM	181
12.3 Reducing User Interpretive Delays with WFM Visualizations	183
12.3.1 Ingrained User Models	184
12.4 Future Work	184
12.4.1 Implementing a Stereo Marine Database	184
12.4.2 PDA Technology Visualization	185
12.4.3 Sonar Registration of 3D Objects and Future Projects	185
12.4.4 Predictive Scouring	186
12.4.5 Underwater Archaeological Site Visualization	186
12.5 Concluding Remarks	187
A Data Structures	189
A.1 DTM	189
A.2 DDT	191
A.3 PIF	191
A.3.1 Calculating a Transformation Matrix for a Pipe Section	192
A.3.2 Pipeline Cross-sections	193
B Dynamic Runtime Objects	194
C Colour Plates	197
References	221

List of Figures

2.1	Earth orbiting satellites (Pratson & Haxby 1997)	10
2.2	Deep Ocean Engineering's Phantom HD2+2 ROV	10
2.3	Video footage from an ROV survey ©2000 Stolt Colmex	11
2.4	Colladon's speed of sound experiments - Switzerland 1826 (Fish 1990)	13
2.5	SBP graphic of a buried pipe	16
2.6	Side scan sonar (Pratson 1997)	17
2.7	Modern side scan sonar imaging (Fish & Carr 2000)	17
2.8	Multibeam sonar (Pratson 1997)	18
2.9	SRD's SVS Sonar Architecture (SRD 1997)	19
2.10	Typical transducer configuration used for pipeline survey	20
2.11	POD analogue video signal	21
2.12	Range Bearing Parameters	22
2.13	A flat seabed pattern received from downward looking sonar	23
3.1	Upson et al. Visualization pipeline	27
3.2	Haber & McNabb Visualization pipeline	27
3.3	Haber & McNabb model with added user feedback	28
3.4	IRIS Explorer	30
4.1	Visualization possibilities for marine data	35
4.2	Iris Explorer visualization of the Montgomery (Courtesy of Christian Mathers, Department of Computer Science, University of Hull)	37
4.3	Example marine visualization using MatLab (MathWorks 2002)	38
4.4	Example real-time GIS marine navigation system ©2002 Maptech	41
4.5	Example screen shot from Fledermaus (Nautronix 2000)	44
4.6	CFloor bathymetric images (Smegvig 2000)	46

4.7	Sample screen shot from DredgePack (Coastalo 2000)	47
4.8	DredgePack profile window (Coastalo 2000)	47
5.1	Extended Haber-McNabb reference model	59
5.2	WFM Pipeline for a basic survey	59
5.3	Example digital terrain map rendered using WFM - 200m ²	61
5.4	Extended WFM Architecture	62
5.5	Area under investigation	68
6.1	Area under investigation	70
6.2	The SS Richard Montgomery	71
6.3	Modern day photograph of the SS Richard Montgomery	72
6.4	Ken Marshall's depiction of the ROV Jason Jr. entering the HMS Titanic	73
6.5	ROV Video image of the HMS Titanic	74
6.6	Ken Marshall's depiction of the HMS Titanic	74
6.7	SS Montgomery Visualization Architecture	75
6.8	Bathymetric data showing the Montgomery	76
6.9	Bathymetric data with accurately positioned shipwreck model	77
6.10	Colour image of wreck bathymetric data	77
6.11	High resolution data shipwreck lying on a reduced resolution seabed (Gouraud shaded)	79
6.12	High resolution data shipwreck lying on a reduced resolution seabed (wire-frame)	79
6.13	WFM Simulating a realistic underwater environment around the Montgomery wreck	80
7.1	Area under investigation	84
7.2	Photograph of blocked harbour wall at low tide	86
7.3	Harbour wall architecture	86
7.4	Harbour wall visualization EDT data	89
7.5	Harbour wall visualization	89
7.6	Virtual harbour wall environment	90
8.1	Area under investigation	92
8.2	Side scan image showing a free-spanning section of pipeline	94

8.3	Pipeline survey paper chart	95
8.4	Typical transducer configuration for pipeline survey	96
8.5	Pipeline categories	96
8.6	Exposed pipeline section	100
8.7	Buried pipeline section - Visible from the cross-section	100
8.8	Investigating pipeline exposure points	101
8.9	Real pipeline, real seabed, virtual screwed anchor	102
8.10	Model validation - Integrating ROV and virtual displays	104
8.11	Pipeline Architecture	104
8.12	Real-time pipeline visualization	107
8.13	State transition / data flow	107
8.14	Real-time WFM architecture	109
8.15	Iterative Dredging Process	111
9.1	Case study evaluation map	114
9.2	Photograph of original base	115
9.3	Depth coloured bathymetric plot	116
9.4	Photograph of barges used in the clear-up procedure	117
9.5	Debris clearance procedure	118
9.6	WFM real-time display of clear up operations	120
9.7	Grab breaking water level with debris flag set	121
9.8	WFM Debris clear-up architecture	123
9.9	WFM implementation in the ROV control cabin (bottom right monitor)	127
9.10	WFM implementation in crane control cabin (bottom right monitor)	127
9.11	Typical Party Chief selected view	130
9.12	Kursk Architecture Step 1	135
9.13	Kursk Architecture Step 2	137
10.1	Case study evaluation map	139
10.2	MV Kovambo Diamond mining vessel	140
10.3	Photographs of the 180 tonne crawler being deployed	141
10.4	Computer model of the tool including correctly scaled 6 foot diver	142
10.5	Tool control cabin	143
10.6	Sample screen shot from DredgePack (Coastalo 2000)	144

10.7	Diamond mining architecture	145
10.8	Tool with 0d heading, 90d slew, 0d pitch and 30d roll	146
10.9	Inserting a new face from a ping	148
10.10	Real-time WFM crawler visualization	150
10.11	Real-time dredging display	151
10.12	Real-time dredging display including crawler positional data (left)	151
10.13	Tool pilot using the WFM display (second display from top left) on board the MV Kovambo	152
10.14	Tool pilot using the WFM display (second display from top left) on board the MV Kovambo	153
10.15	Tool deployment visualization	156
10.16	DeBeers real-time diamond mining	157
11.1	BP Centre for Visualization (BP 2001)	162
11.2	Virtual Great Barrier Reef project (Refsland 1998)	163
11.3	WFM architecture implementing stereoscopic and hemispheric projections .	167
11.4	Proposed architecture for remote offshore visualization and monitoring . .	169
11.5	Proposed architecture for tele-operation offshore visualization and monitor- ing	172
11.6	WFM Stereographic view of an exposed section of pipeline (red-blue glasses required)	173
11.7	WFM Stereographic view of a free-spanning section of pipeline (red-blue glasses required)	174
11.8	WFM Hemispheric pipeline projection including wireframe hemisphere mesh	175
11.9	WFM Hemispheric pipeline projection	175
12.1	WFM Version 1.0	180
12.2	Real-time Pipelay Visualization	182
12.3	Real-time Pipelay Visualization	182
12.4	Reality and the user model	183
A.1	DTM Structure	190
A.2	DDT directory structure	191
B.1	CSimpleObject and CSimpleView (Smetak 1997)	196

C.1	Chapter 6 : Bathymetric data showing the SS Richard Montgomery	198
C.2	Chapter 6 : Bathymetric data with accurately positioned shipwreck model .	199
C.3	Chapter 6 : Coloured bathymetry with accurately positioned shipwreck model	200
C.4	Chapter 6 : Simulating a realistic underwater environment using fog	201
C.5	Chapter 6 : High resolution data shipwreck lying on a reduced resolution seabed (Gouraud shaded)	202
C.6	Chapter 6 : High resolution data shipwreck lying on a reduced resolution seabed (wireframe)	203
C.7	Chapter 7 : Harbour wall visualization EDT data	204
C.8	Chapter 7 : Virtual harbour wall environment	205
C.9	Chapter 8 : Investigating pipeline exposure points	206
C.10	Chapter 8 : Real pipeline, real seabed, virtual screwed anchor	207
C.11	Chapter 8 : Iterative Dredging Process	208
C.12	Chapter 8 : Model validation - Integrating ROV and virtual displays	209
C.13	Chapter 9 : Depth coloured bathymetric plot of Holy Loch	210
C.14	Chapter 9 : WFM real-time display of clear up operations	211
C.15	Chapter 9 : Grab breaking water level with debris flag set	212
C.16	Chapter 9 : Typical party chief selected view	213
C.17	Chapter 10 : Real-time WFM crawler visualization	214
C.18	Chapter 10 : Real-time dredging display including crawler positional data (left)	215
C.19	Chapter 10 : Tool deployment visualization	216
C.20	Stereographic view of an exposed section of pipeline (red-blue glasses required)	217
C.21	Stereographic view of a free-spanning section of pipeline (red-blue glasses required)	218
C.22	Hemispheric pipeline projection including wireframe hemisphere mesh . . .	219
C.23	Hemispheric pipeline projection	220

Abstract

In 85 B.C a Greek philosopher called Posidonius set sail to answer an age-old question: how deep is the ocean? By lowering a large rock tied to a very long length of rope he determined that the ocean was 2km deep. These line and sinker methods were used until the 1920s when oceanographers developed the first echo sounders that could measure the water's depth by reflecting sound waves off the seafloor. The subsequent increase in sonar depth soundings resulted in oceanologists finally being able to view the alien underwater landscape. Paper printouts and records dominated the industry for decades until the mid 1980s when new digital sonar systems enabled computers to process and render the captured data streams.

In the last five years, the offshore industry has been particularly slow to take advantage of the significant advancements made in computer and graphics technologies. Contemporary marine visualization systems still use outdated 2D representations of vessels positioned on digital charts and the potential for using 3D computer graphics for interacting with multidimensional marine data has not been fully investigated.

This thesis is concerned with the issues surrounding the visualization of offshore activities and data using interactive 3D computer graphics. It describes the development of a novel 3D marine visualization system and subsequent study of marine visualization techniques through a number of offshore case studies that typify the marine industry.

The results of this research demonstrate that presenting the offshore engineer or office based manager with a more intuitive and natural 3D computer generated viewing environment enables complex offshore tasks, activities and procedures to be more readily monitored and understood. The marine visualizations presented in this thesis take advantage of recent advancements in computer graphics technology and our extraordinary ability to interpret 3D data. These visual enhancements have improved offshore staffs' spatial and temporal understanding of marine data resulting in improved planning, decision making and real-time situation awareness of complex offshore data and activities.

Acknowledgements

I would like to thank the Teaching Company Directorate, Sonar Research and Development Ltd and the University of Hull for their support over the last six years.

The Teaching Company Directorate provided the necessary funding for an entertaining offshore survival training course that included underwater helicopter escape drills, fire fighting and first aid. Gaining my offshore certificate provided me with the necessary qualifications to work in the offshore industry and to develop and test first hand the marine visualizations described in this thesis.

From Sonar Research and Development Ltd particular recognition must go to Dr Peter Stevens, my industrial supervisor and former managing director of Sonar Research and Development. All the staff at SRD are to be thanked but particularly Rafe Montgomery whose friendship and intellect I will be forever grateful. Memories of helicopter escapes from the Namibian police (due to lack of diamond mining permits) will always bring a smile to my face. Rafe is also to be thanked for the use of his SRDV software which provided the foundations for my 3D marine visualization system. Special thanks also to Bill Austin, Brian Walker, Kevin Brown, John Smith, Mark Thomas, Mat the Cat, Mat the Kitten, Alan McClaud, Andy 'P', Paul Richards, Pete the Brummy, Adrian Machew, John Topham, Iain Kelwick, Anne Ryan, Dangerous Dave, Steve Sansom, Katie and Simon 'Money Man Hill'. Without all these people (and others) this work would not have been possible.

From the University of Hull's Department of Computer Science, first and foremost my academic supervisor Derek Wills (formally of British Aerospace) for his guidance and support over the years, Professor Graham Brookes for introducing me to the field of seabed visualization, Dr Helen Wright for her helpful conversations, support and advice (especially with delivering my first conference paper in the U.S.), James 'Wizard' Ward for always being there (again!) to share a cold beer and to answer those niggly programming questions.

Professor Min Chen and Dr Steve Treavett from the University of Swansea who convinced me to write this thesis in LaTeX thus saving me six man months of hair pulling.

Mark Taylor and Derek Lorrison for teaching me that 'Mamma don't allow'.

Edward Swift for his friendship, Papa Smurf singing and over a million cups of tea.

Dr Ivan Vaghi for believing in fresh and 'preposterous' ideas.

Cleggy, Jayne, Ethan and Hollie for everything - especially looking after me in the early years.

Finally I would like to thank my parents, Michael and Bernadette and my sister Katie for their constant support and encouragement. Last but not least, I would like to thank la mia principessa Cinzia, for her patience and understanding when I was offshore for months at a time, her constant 'have you worked on your thesis today?', her wonderful pasta con panna e prosciutto and her unfailing faith in my work.

Thank you all.



Paul Chapman

Hull, England

July 31, 2003

Relevant Publications

Refereed Conference Proceedings

Chapman, P. M., Wills, D., Stevens, P. and Brookes, G. (1998), Seabed Visualization, in D. Ebert, H. Hagen and H. Rushmeier, eds, *IEEE Visualization 98*, IEEE, pp. 479-481. ISBN 0-8186-9176-X.

Chapman, P. M., Wills, D., Stevens, P. and Brookes, G. (1999b), Whole Field Modelling - Effective Real-time and Post-survey Visualization of Underwater Pipelines, in M. G. David Ebert and B. Hamann, eds, *IEEE Visualization 99*, IEEE, pp. 445-448. ISBN 0-7803-5897-X.

Chapman, P. M., Wills, D., Stevens, P. and Brookes, G. (2000), Real-time Visualization of the Clear-up of a Former U.S. Naval Base, in M. G. David Ebert and B. Hamann, eds, *IEEE Visualization 2000*, IEEE, pp. 505-508. ISBN 0-7803-6478-3 (Awarded Best Conference Case Study Paper).

Chapman, P. M., Viant, W. J., Constructing Immersive Virtual Environments for the Visualization of Underwater Archaeological Sites, Submitted to CAA - Computer Applications and Quantitative Methods Archaeology Conference, Prato, Italy, 13-17 April 2004.

Refereed Journal Publications

Chapman, P. M., Wills, D., Stevens, P. and Brookes, G. (1999a), Visualizing Underwater Environments using Multi-frequency Sonar, *IEEE Computer Graphics and Applications* 19(5), 61-65. ISSN 0272-1716 (invited paper).

Chapman, P. M., Wills, D., Stevens, P. and Brookes, G. (2001), Visualization Viewpoints: Real-time Visualization in the Offshore Industry, *IEEE Computer Graphics and Applications* 21(4), 6-10. ISSN 0272-1716 (invited paper).

Non-refereed Publications

SRD, 2001, Revolutionary Control System Aids Subsea Diamond Mining, Underwater Contractor International, 5(1), 5-6.

Awards

Best Case Study Paper at the 10th IEEE Visualization Conference 2000 in Salt Lake City, Utah. (Chapman et al. 2000). www.erc.msstate.edu/conferences/vis00/index.html

The BP and Society for Underwater Technology International Underwater Image Competition 2001. 3rd Prize for Visualization of the SS Richard Montgomery by Paul Chapman, Sonar Research and Development Ltd (UK). The winning images can be viewed on the internet at: www.soc.soton.ac.uk/GDD/img2001/web2.html

The reserach outlined in this thesis was awarded a grade of 'Excellent' from its funding body: The Teaching Company Directorate.

Oceanology Presentations

Work contained within this thesis was also presented by the author to the public at the following annual International Oceanology conferences:

Oceanonlogy Conference 1998, The Metropole, Brighton.

Oceanonlogy Conference 1999, The World Trade Centre, Singapore.

Oceanonlogy Conference 2000, The Metropole, Brighton.

Internet Publication

The 2001 Computer Graphics and Applications 'Visualization Viewpoints' article (Chapman 2001) was chosen as a special case visualization and published on the IEEE Computer website for one week in September 2001. Online article is located at: www.computer.org/cga/homepage/offshore.htm

Chapter 1

Introduction

There is one feature that will surely increase the complexity of visualization systems in the years to come and that's real 3D visualization of the underwater environment, using digital terrain models, and three dimensional drawings of platforms and other structures. 3D is more intuitive to work with and will save both time and money.

Mr Bert Jeeninga, March 1998
General Positioning Systems
(Jeeninga 1998)

This thesis is concerned with the issues surrounding the visualization of offshore activities and marine data using interactive 3D computer graphics. Current marine visualization systems rely on outdated graphics technology and antiquated user interfaces that have not made allowances for recent advances in computer graphics and offshore marine technologies.

In the last five years, significant technological advancements have been made in the computer graphics industry resulting in the production of high speed / low cost graphics processing units (GPUs)¹. This has been specifically driven by an extremely competitive and dynamic games industry (Rollings 1999). The scientific software industry has taken full advantage of the advances in computer graphics technology and it is now possible

¹An example company that has significantly improved the quality of graphics technology is nVidia (Dang 2001) (nVidia 2002) Founded in 1993, nVidia has quickly become the worldwide leader in GPUs for the desktop PC.

for scientists to interact with large data-sets, such as MRI² volume data, using desktop computers and the latest GPU (previously this work would only have been possible using dedicated Silicon Graphics workstations).

Conversely, contemporary marine visualization systems have been particularly slow to incorporate the latest graphics technologies in their systems. Most marine visualization systems still use outdated 2D representations of vessel positions on digital charts and very few companies seem willing to investigate the use of 3D computer graphics for interacting with multi-dimensional marine data.

This thesis develops the hypothesis that presenting offshore engineers and office based management with more intuitive and natural computer generated viewing environments enables complex offshore tasks, activities and procedures to be more readily monitored and understood. The marine visualizations presented in this thesis take advantage of recent advancements in computer graphics technology and, more importantly, our extraordinary ability to interpret 3D spatial data (Malone 1983), (Spence 2001).

Research can be both quantitative and qualitative. Quantitative research originated in the natural sciences and is related to numbers, logic and the objective. For example, laboratory experiments and numerical methods such as mathematical modelling. Qualitative research which originated in the social sciences focusses on words, images and the subjective. For example, case study research and ethnography. The work outlined in this thesis is concerned with qualitative research as qualitative research is designed to help researchers understand people and the social and cultural contexts within which they live and work (Myers 1997). Kaplan & Maxwell (1994) state that the goal of understanding a phenomenon from the point of view of the participants and its particular social and institutional context is largely lost when textual data are quantified.

²Magnetic resonance imaging or MRI is an imaging technique used primarily in medical environments to produce high quality images of the inside of the human body.

1.1 Aim and Objectives of Thesis

The aim of the doctorate research is:

to research and demonstrate the effectiveness of 3D computer graphics environments for visualizing offshore marine activities and collected data, at both a planning pre/post-survey level and for real-time situation awareness.

The following objectives were identified as important for achieving this aim.

1. To investigate current marine visualization techniques and methods in order to determine the current state of today's marine visualization technology.
2. To describe the development and implementation of a 3D marine visualization methodology that addresses the limitations and deficiencies of contemporary marine systems described in item 1.
3. To verify the practicality and effectiveness of the developed marine visualization system through a wide range of case studies that apply the system to diverse real offshore scenarios such as shipwreck surveys in Sheerness, UK to Diamond mining in Namibia, South Africa.
4. To conduct a feasibility study into the use of stereoscopic displays and immersive virtual reality (VR) technologies for visualizing and interacting with offshore marine data. Immersive technologies will include items of hardware such as head mounted and hemispheric displays.
5. To research and report on any psychological end-user observations relating to items 3 and 4. This would address items such as observing how an 'alien' 3D marine visualization system could be integrated into an already functioning offshore vessel control-room. Observations may provide information relating to how offshore industry personnel with varying levels of experience interface to the marine visualization system. How can animosities and reluctance to change be overcome? How can this knowledge be used to further improve our interpretation of marine data and implementation of effective marine visualization systems?

1.2 Thesis Outline

Chapter 2 introduces the reader to the offshore industry and considers a sample set of activities that characterise the offshore industry. These include shipwreck and pipeline inspection, dredging surveys and debris search and recovery. Marine topography acquisition methods are also considered such as satellites, photography, lidar and sonar. Special attention is given to the use of sonar due to its relevance in later chapters.

Chapter 3 explores the relatively new scientific field of visualization. Visualization is primarily concerned with how computer graphics can be used to effectively impart insight and understanding into large quantities of numerical data. The chapter introduces a popular visualization reference model that is used in later chapters to support discussions of marine visualization and data flow systems.

Chapter 4 reports on the marine visualization tools that are currently available to the offshore engineer in order to visualize their aquatic data. The chapter identifies four possible visualization solutions: generic visualization software, geographical information systems, off-the-shelf marine visualization systems and purpose built 'DIY' solutions. The chapter defines a set of desirable characteristics for a marine visualization system and then evaluates how contemporary marine visualization systems perform against these criteria. The chapter concludes by proposing a high level specification for a new marine visualization system that addresses the deficiencies and limitations of the marine visualization systems identified previously in the chapter.

The high level specification for a marine visualization system (identified in Chapter 4) is then used for the design and implementation of a 3D marine visualization system, hereby referred to as the 'Whole Field Modelling System' or WFM. Chapter 5 identifies the hardware and software used for WFM's implementation and describes the dataflow needed to visualize a simple seabed terrain dataset gathered from an offshore marine survey.

Chapters 6 to 10 provide detailed descriptions of WFM's immersion into the offshore industry through a wide selection of case studies that epitomise the offshore industry. Specifically: shipwreck, harbour wall, pipeline monitoring, debris clear-up and diamond mining. Each new scenario increases in complexity and provides new challenges in the research and development of effective offshore marine visualizations. Psychological and end user notes

1.2 Thesis Outline

were made during all case study implementations and provide some interesting observations.

Chapter 11 considers the benefits of immersive VR techniques for improving our understanding of offshore operations. A modification to the WFM architecture is proposed that permits stereographic or 'fisheye' views to be displayed that can then be used with either stereo glasses, head mounted displays or hemispheric displays. Two real-time scenarios are proposed that use immersive marine visualization and a post survey stereographic visualization is also considered for the analysis of pipeline inspection data.

Chapter 12 reviews the aims and achievements of the research and highlights the main contributions of this doctorate research. Five areas of future offshore marine research are briefly considered: stereo marine databases, PDA marine visualizations, sonar registration of 3D objects, predictive scouring and underwater archeological visualization.

2.2 Pipeline Inspection

Other shipwreck inspections may involve the location of a ruptured hull leaking oil into the marine environment. For example, H.M.S Royal Oak was torpedoed and sunk in Scapa Flow in October 1939 (Lienhard 2000). In 1998 the vessel needed inspecting to locate, and plug a ruptured hull that was starting to leak significant amounts of oil into the environment. Live underwater video footage mounted on a remotely operated vehicle (ROV) facilitated the inspection process.

A more recent example of shipwreck inspection was the survey of the Russian submarine, The Kursk, which sank August 12, 2000 with the loss of all 117 crew members (Link 2000). Considerable damage to the 1st and 2nd bow compartments of the Kursk were revealed through video footage and high resolution sonar data. The data revealed that the conning tower and emerging camera were also damaged and that one cover of the missile trunk was torn off. This data was imperative for calculating and planning rescue attempts and further dives on the stricken submarine.

2.2 Pipeline Inspection

The seas and oceans contain a spaghetti-like labyrinth of underwater pipes and cables that criss-cross the seafloor, providing fuel and communications throughout the world. The condition and welfare of these pipelines remain the responsibility of the pipeline's asset owner. Companies generally arrange for inspection of these pipelines annually by commissioning an oceanographic survey company to gather data relating to the pipe's condition and surrounding seabed topography. Video footage captured from ROVs (Section 2.6.2) and 2D images from side scan sonar (Section 2.6.4) typify data acquisition methods for pipeline inspection.

The status of the pipe on the seabed may occupy one of three categories: buried, exposed or free-spanning (Chapman, Wills, Stevens & Brookes 1999a). Generally, a buried pipeline will stay fixed in its position protected from the underwater environment. However, as harsh underwater currents scour the seabed (Stride 1982), sections of pipeline become exposed. Further seabed scouring can remove all support from beneath the pipeline, leaving it free-spanning. Pipeline owners need to identify exposed and free-spanning pipelines as quickly as possible because of the increased strain on the pipeline that could ultimately result in a

2.3 Route Survey

fracture³.

2.3 Route Survey

Before the complex procedure of seabed pipe laying can be initiated, a route survey must be performed to determine the best route and resting place for a pipeline. Comprehensive, high quality surveys are essential to the planning and deployment of underwater pipelines. This is of particular importance at greater depths where both the complexity and cost of operations increase.

A poor survey, resulting in a pipe being positioned over undulating terrain, will put unnecessary strain on the pipe reducing its life-span and increasing the risk of an early fracture. By carefully surveying the proposed site for the pipe, an effective and safe path can be found. These same principles can be used to reposition an oil-rig from its construction site to its allocated deployment site.

2.4 Dredging Surveys

Dredging (OPL 1998) is the process of relocating silt and sand from the seabed. This process uses dedicated vessels called dredgers that use specially developed dredge arms that can be lowered down and positioned directly over the seafloor. The dredge-head at the end of the arm is carefully positioned over the area to be dredged and a suction pump activated. Dredging is typically used for deepening shipping channels and preparing a resting channel for a pipeline.

2.5 Debris Search and Recovery

Debris search and recovery is required for the location and possible removal of objects from the seabed for either environmental or commercial reasons. A recent example of debris search and recovery was the MOD cleanup operation in Holy Loch, Scotland (Chapman, Wills, Stevens & Brookes 2000). The loch contains a large amount of wreckage and debris

³A fractured pipeline can be extremely dangerous and costly due to the high pressures and potentially dangerous content. For example, in a matter of seconds, a ruptured oil pipe can leak thousands of gallons of crude oil into the sea, destroying a fragile marine ecosystem. A fractured pipeline carrying gas can bubble to the surface and poison a vessel's crew or explode if ignited.

2.6 Marine Data Acquisition Methods

left after the departure of a former U.S. Nuclear Submarine Base. Surveying the loch using sonar equipment allows the underwater debris to be precisely located. Typically, a large magnet or crane can then be positioned onto the debris to lift the material through the water and onto a waiting barge.

Search and recovery is not restricted to debris. It may include searching for an ejector seat from a military jet, searching for a lost shipwreck such as the Titanic (Ballard, Archbold & Crean 1995) or searching for a plane on the seafloor after it has disappeared from radar.

2.6 Marine Data Acquisition Methods

The offshore marine applications discussed in the previous section all have one thing in common: they all require accurate underwater seabed terrain mapping. This section briefly describes the main technologies used to gather submarine data, specifically information related to seabed topography.

The marine data acquisition methods considered in this section are earth orbiting satellites, photography and video footage, airborne lidar bathymetry and sonar systems. Sonar systems will be the main source of raw data input discussed in this thesis and will consequently be described in more detail⁴.

2.6.1 Earth Orbiting Satellites

Satellites cannot measure seafloor depth directly, but they can sense variations in the elevation of the water at the surface of the ocean as shown in Figure 2.1. The satellite will bounce radar pulses off the ocean below it and permit the sea-surface height to be calculated as the position of the satellite is known.

The earth's oceans can vary in relief by as much as 200m (Pratson & Haxby 1997) reflecting minute differences in the earth's gravity from place to place that cause water to distribute itself unevenly. These variations in ocean surface are due to variable seafloor topography. For example a large submerged volcano will pull water towards it producing a bulge in the ocean surface above it. Conversely, the ocean surface can downwarp over seabed trenches.

⁴Note that the visualization techniques discussed will still be applicable to the other survey techniques.

2.6 Marine Data Acquisition Methods

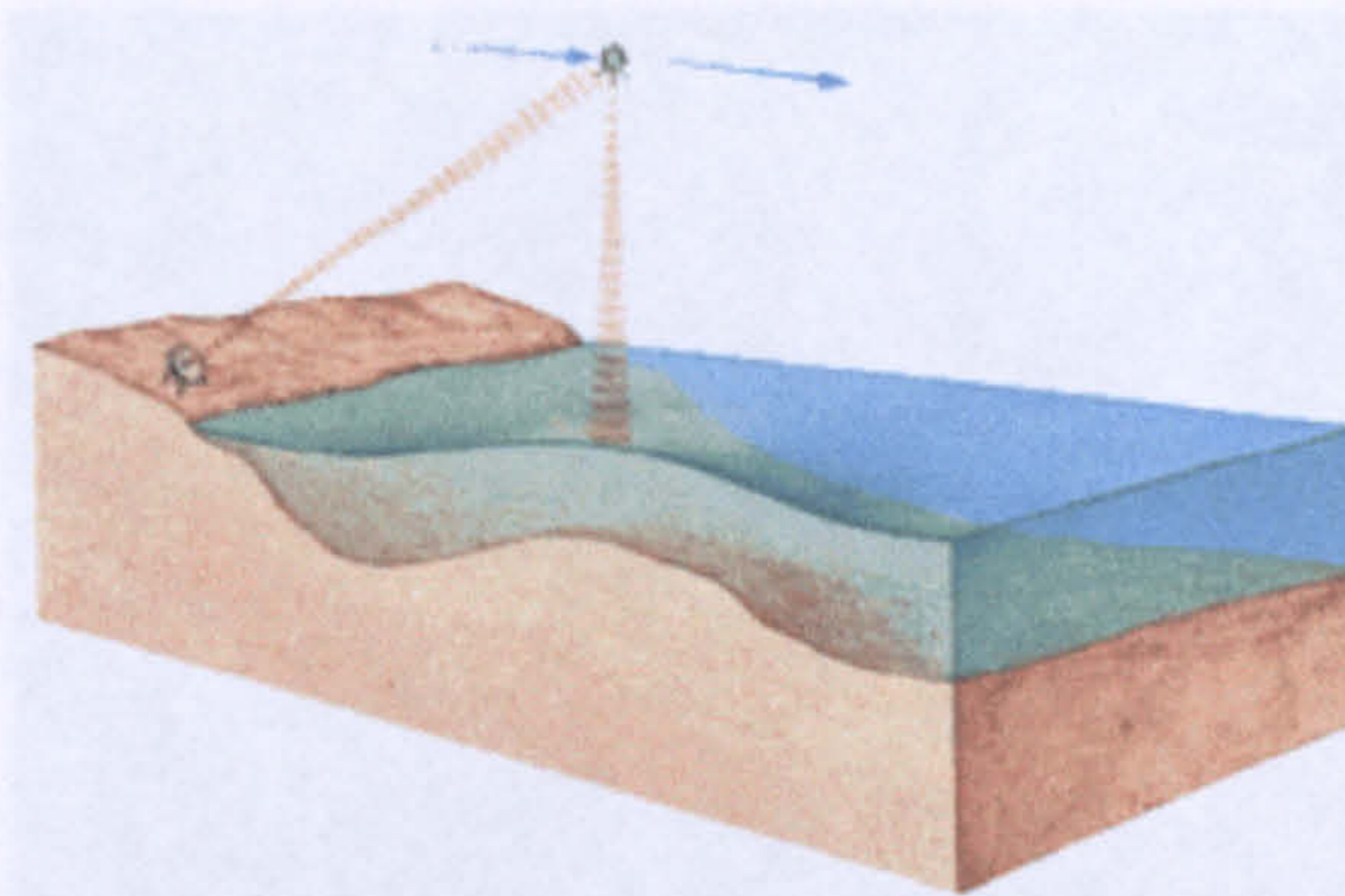

Figure 2.1: Earth orbiting satellites (Pratson & Haxby 1997)

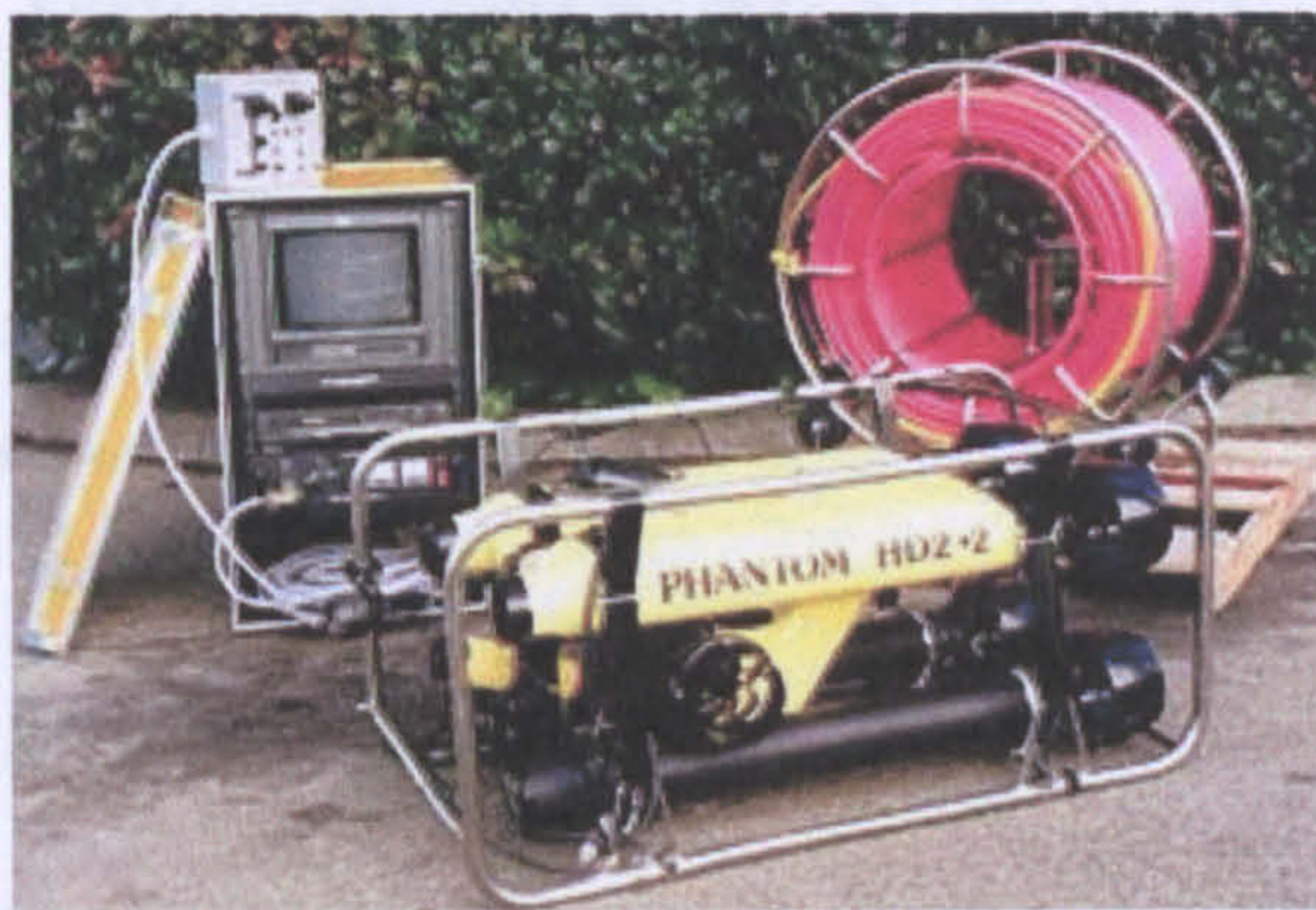

Figure 2.2: Deep Ocean Engineering's Phantom HD2+2 ROV

One problem with measuring the gravitational pull of the underwater topography are gravity variations. For example continental margins can reflect differences in the density of the submerged rock rather than in the seabed topography. The main advantage of satellites is that they permit large geographical areas to be surveyed and have been used to survey areas not studied using other techniques.

2.6.2 Photography and Video Footage

Underwater photography and video can provide the most detailed view of the seafloor (Pratson & Haxby 1997). Cameras are however limited to short distances as the artificial light does not penetrate the seawater effectively. This is due to the light reflecting back off the sediment, silt and algae in the water. These cameras are usually placed on a remotely operated vehicle or ROV (OPL 1999)(Figure 2.2).

2.6 Marine Data Acquisition Methods



Figure 2.3: Video footage from an ROV survey ©2000 Stolt Colmex

Figure 2.3 shows a video survey of a pipeline off the West coast of England. The image depicts significant damage to the concrete coating around the pipeline. Video from the mounted ROV cameras can provide extremely detailed information if the environmental conditions permit⁵.

2.6.3 Airborne Lidar Bathymetry

Airborne lidar bathymetres operate by emitting a pulse of light which travels from an airborne transmitter to the water surface where some energy is reflected at the sea surface and the remaining energy passes through the water column and reflects off the sea bottom. The reflected energy is recorded by an airborne receiver and the time difference between the water surface and sea-bottom returns provide the water depth. An example of airborne lidar bathymetry is the SHOALS system (Lillycrop, Irish & Parson 1997) which operates from a Bell 212 helicopter at an altitude and speed of 200m and 30m per second respectively. SHOALS emits 200 laser pulses per second and provides depth measurements over a 4m horizontal grid. This translates to high density survey coverage at a rate of 8km² per hour.

The difference in surveying speed between these airborne bathymetres and other technologies is significant. Using a conventional single beam acoustic system (Section 2.6.4) may require several days for a particular survey. The same survey area may be completed in a few hours using the airborne lidar bathymetric method. However, there is one major

⁵Apart from poor visibility due to silt and sand reflecting light from the ROV's halogen lamp, indirect problems relating to poor video results may include strong underwater currents making piloting the ROV extremely difficult.

2.6 Marine Data Acquisition Methods

constraint for any lidar bathymetric system and that is water clarity. Even in optically clear waters, SHOALS can only collect data to a depth of 40m which significantly limits the system's deployment possibilities. Nevertheless, these new systems are extremely powerful for shallow water wide area surveys.

2.6.4 Sonar Technology

Sonar technology is the preferred method for seabed imaging. Sonar, an acronym for Sound Navigation and Ranging, is a technique for determining the distance and direction of underwater objects by acoustic means (Fish & Carr 1990) (Urlick 1975). Sound waves are reflected (or emitted) from the object and are detected by sonar apparatus and analysed for the information they contain. Sonar was initially considered as a method for the detection of submarines and icebergs. By 1918 an operational system had been built by U.S and British scientists.

Leonardo da Vinci is credited with the earliest known reference to underwater sound (Urlick 1975). In a logbook dated 1490 he noted that listening to one end of a long tube with the other end in the sea, ships could be heard over a great distance. Historically, mariners have always noted that sound travels well in the dense underwater environment.

Speed of Sound in Water

Nearly all underwater systems rely on the accurate prediction of the speed of sound in water. Underwater acoustics as a research discipline began in 1826 when Daniel Colladon (Fish & Carr 1990) measured the speed of sound in water on Lake Geneva, Switzerland (depicted below in Figure 2.4). Colladon positioned two boats 16km apart. On the first boat, he fastened a large trumpet fitted with a membrane that would respond to underwater sound. In the second boat he suspended a large bell underwater. The second boat also contained a small pan of flash powder and a flare attached to a large hammer (also suspended underwater) all controlled by a bell-ringer in the boat.

Colladon's plan was to simultaneously ignite the flash powder and hit the bell with the hammer. His theory assumed that the light from the powder would travel the 16km instantaneously, while the sound of the ringing bell would take some time to travel the distance. In the second boat, Colladon started a clock timer when he saw the bright flash.

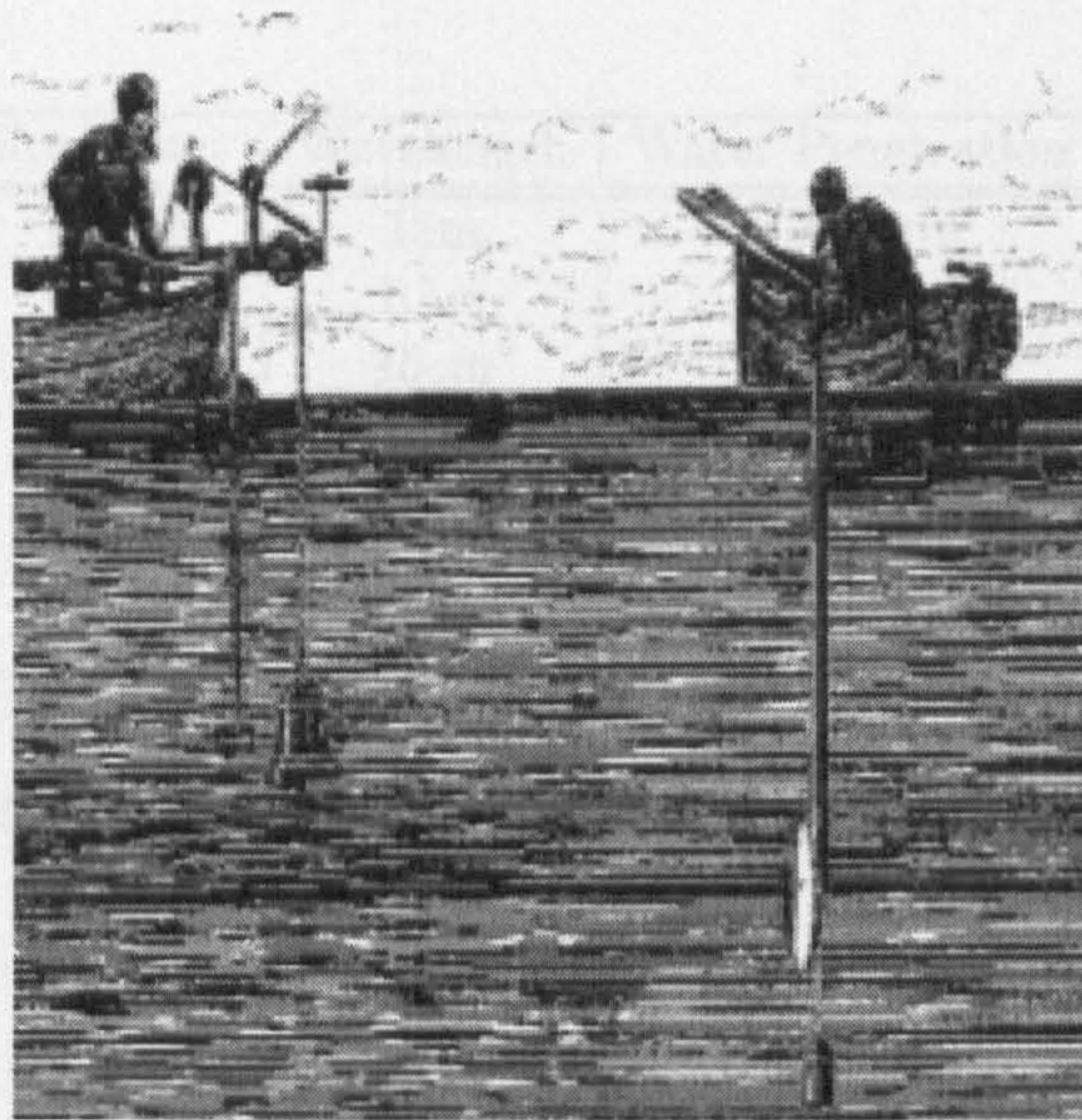

Figure 2.4: Colladon's speed of sound experiments - Switzerland 1826 (Fish 1990)

He stopped the clock when he heard the sound through the trumpet about ten seconds later.

Colladon empirically calculated the speed of sound in water as 1435m per second at a water temperature of 8C. This is within 0.21% of the currently accepted value of 1438m per second, which is quite an achievement considering the limited resources available to him.

This section now introduces the main forms of sonar in use today. Specifically: simple echo sounders, sub-bottom profilers, side scan sonar, multibeam sonar, forward looking sonar and swathe bathymetry systems.

Echo Sounders

Echo sounders are the simplest form of sonar. They calculate the depth of the water directly underneath the vessel by timing the duration of a single ping to the surface and back.

The basic single beam echo sounder operates by applying an electrical pulse to a piezo-electric transducer. The transducer converts the electrical energy into sound energy which is directed towards the seabed. The sound energy is then reflected off the seabed and travels back towards the transducer.

The distance between the transducer and the seabed is calculated using Equation 2.6.1 where D = Distance, V = Velocity of sound in water and T = Time signal between transmit

2.6 Marine Data Acquisition Methods

Frequency	Wavelength	Water Penetration
100Hz	15m	>1000km
1KHz	1.5m	>100km
10KHz	15cm	10km
25KHz	6cm	3km
100KHz	1.5cm	600m
500KHz	3mm	150m
1MHz	1.5mm	50m

Table 2.1: Relationship between frequency, wavelength and distance

and receive.

$$D = \frac{V \cdot T}{2} \quad (2.6.1)$$

The frequency of the sound wave determines the range of the echo sounder. The lower the frequency, the greater the range. The wavelength of the transmitted signal determines the resolution of the echo sounder; a shorter wavelength results in a greater resolution.

Frequency and wavelength are associated by Equation 2.6.2 where λ = wavelength, V = Velocity of sound in water and F = Frequency.

$$\lambda = \frac{V}{F} \quad (2.6.2)$$

It can be seen from Equation 2.6.2 that the wavelength and frequency are inversely proportional, i.e. a higher frequency results in higher resolution. An ideal echo sounder would have a multiple frequency capability. For example, 210KHz for short range high resolution surveys and 33KHz for surveys at 1km depth.

The relationship between frequency, wavelength and range is illustrated in Table 2.1 which assumes a fixed sound velocity of 1500m/s (SRD 1990).

The water depth determines the number of pings that can be transmitted per second ('pps' or 'ping rate'). In one second, sound travels 1500m underwater therefore it takes 0.66ms for sound energy to travel 1m (Equation 2.6.3).

$$\frac{1000ms}{1500mps} = 0.66ms \quad (2.6.3)$$

2.6 Marine Data Acquisition Methods

The ping needs to travel back to the transducer so the distance travelled is actually 200m therefore 133ms is required for 100m water depth.

The ping rate for 100m of water can therefore be calculated as 7.5 pings per second.

$$\frac{1000ms}{133} \approx 7.5pps \quad (2.6.4)$$

Other factors also need to be taken into account when performing surveys but are beyond the scope of this thesis. For example, the speed of the vessel and survey line separation all determine the gathered data density (Fish & Carr 1990).

Sub Bottom Profiler

Sub bottom profilers (SBPs) provide an image of the makeup of the seabed itself. They emit a low frequency signal capable of penetrating deep into the seafloor. Data collected can be used to identify the ground composition (mud, sand, clay etc) which is useful for activities such as determining a suitable seabed composition for an oilrig platform. SBPs are also used to calculate the depth of a buried pipe as the pipe material (usually a concrete jacket) will give a much harder return than its sandy neighbour.

SBP data can now be recorded digitally and post-processed to enhance the signal and remove non-coherent noise. Seismic imaging produces cross-sections of the seafloor which can be as deep as 10,000m but these rely on extremely low frequencies to achieve the penetration.

The SBP image shown in Figure 2.5, shows a parabola formed by a buried pipe that would not be detectable using conventional sonar. The lower frequency sound has travelled through the seabed and reflected off the pipe. The top of the parabola represents the top of the pipe. To image a buried pipeline using a SBP, the pipeline must be approached at right angles to the pipeline's lay. Consequently, as the survey vessel approaches the pipe, the pipeline returns will be drawn closer to the top of the rendered output as the returned echoes arrive much faster. As the vessel passes over the pipeline, the shortest distance between SBP and pipe is attained (the top of the parabola). Assuming the vessel passes the pipe at a constant speed and perfectly orthogonal to the pipeline's direction, then a perfect parabola will be drawn providing the survey team with an accurate position of the

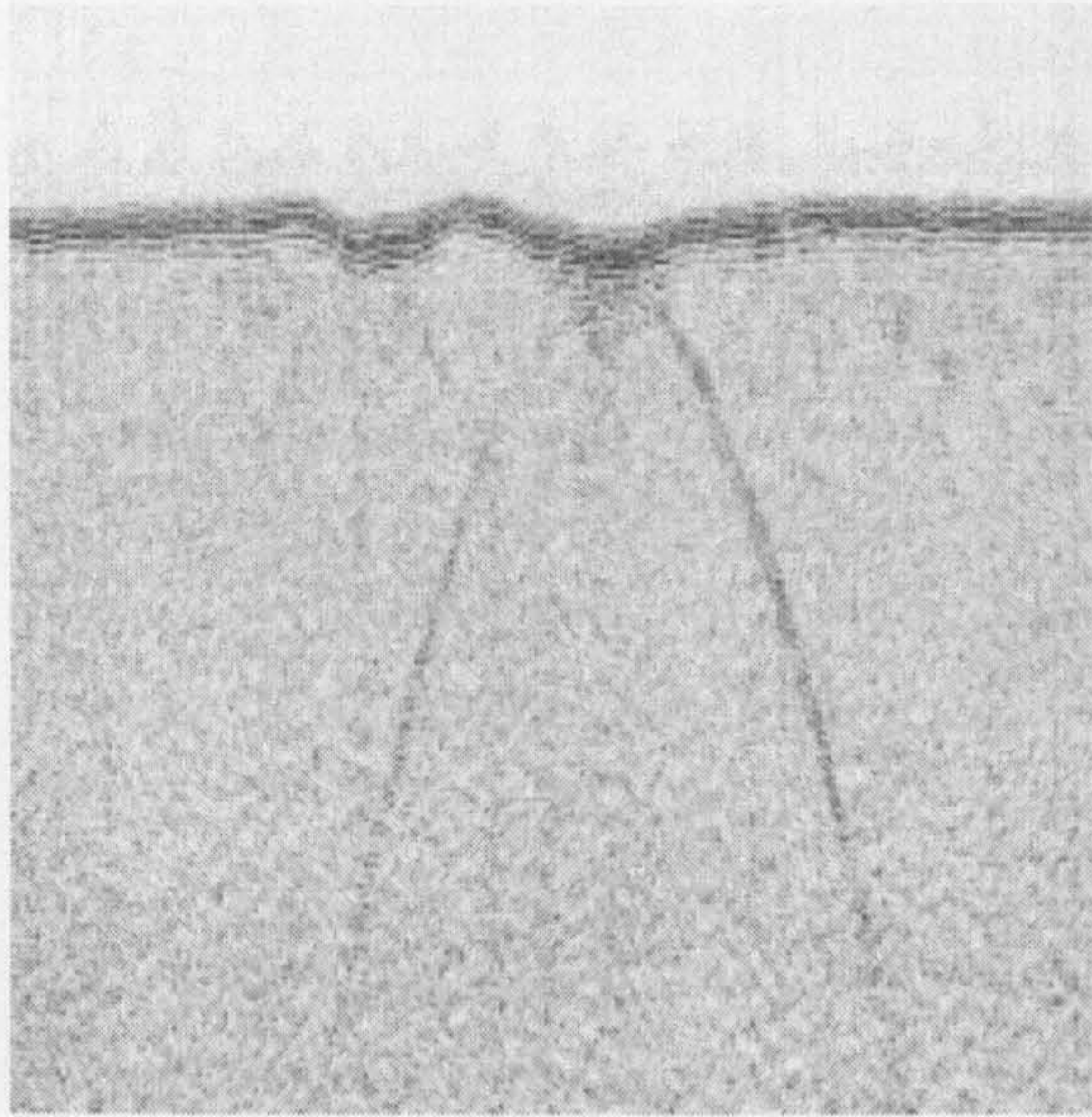

Figure 2.5: SBP graphic of a buried pipe

buried pipeline. The frequency of these pipeline crossings generally range from 50 to 100m intervals along the pipe. If the ship is not orthogonal to the pipe, the parabola will be lost⁶.

Side Scan Sonar

Side scan sonar provides yet another perspective of the seafloor. Two sonar units are attached to a towfish or sled (Figure 2.6) and act as both sound sources and listening devices. These units emit bursts of sound outward to either side. If the seafloor is flat and smooth, none of the energy emitted will be reflected back. If the seafloor is rough, the sound hitting the bottom will be scattered in all directions, and some will return to the sonar towfish. By equating the amplitude (volume) of the recorded echoes to different shades of grey and displaying the results to show the distance from the towfish, scientists can obtain an image of the texture of the seafloor that looks similar to a black and white photograph. A side scan image does not indicate the direct altitude of the underwater terrain although height calculations can be made using shadows (Fish & Carr 1990).

Figure 2.7 shows a modern digitised side scan sonar image of three shipwrecks resting

⁶The SBP graphic is formed over time (x axis) and distance from the responder (y axis). Therefore the parabola's peak shows the shortest distance to the responder. The granularity of the pixels dictate the strength of the returned signal (hence a hard concrete pipe coating is represented by a dark parabola). The final dataset equates to a 2D scalar dataset or ε_2^s .

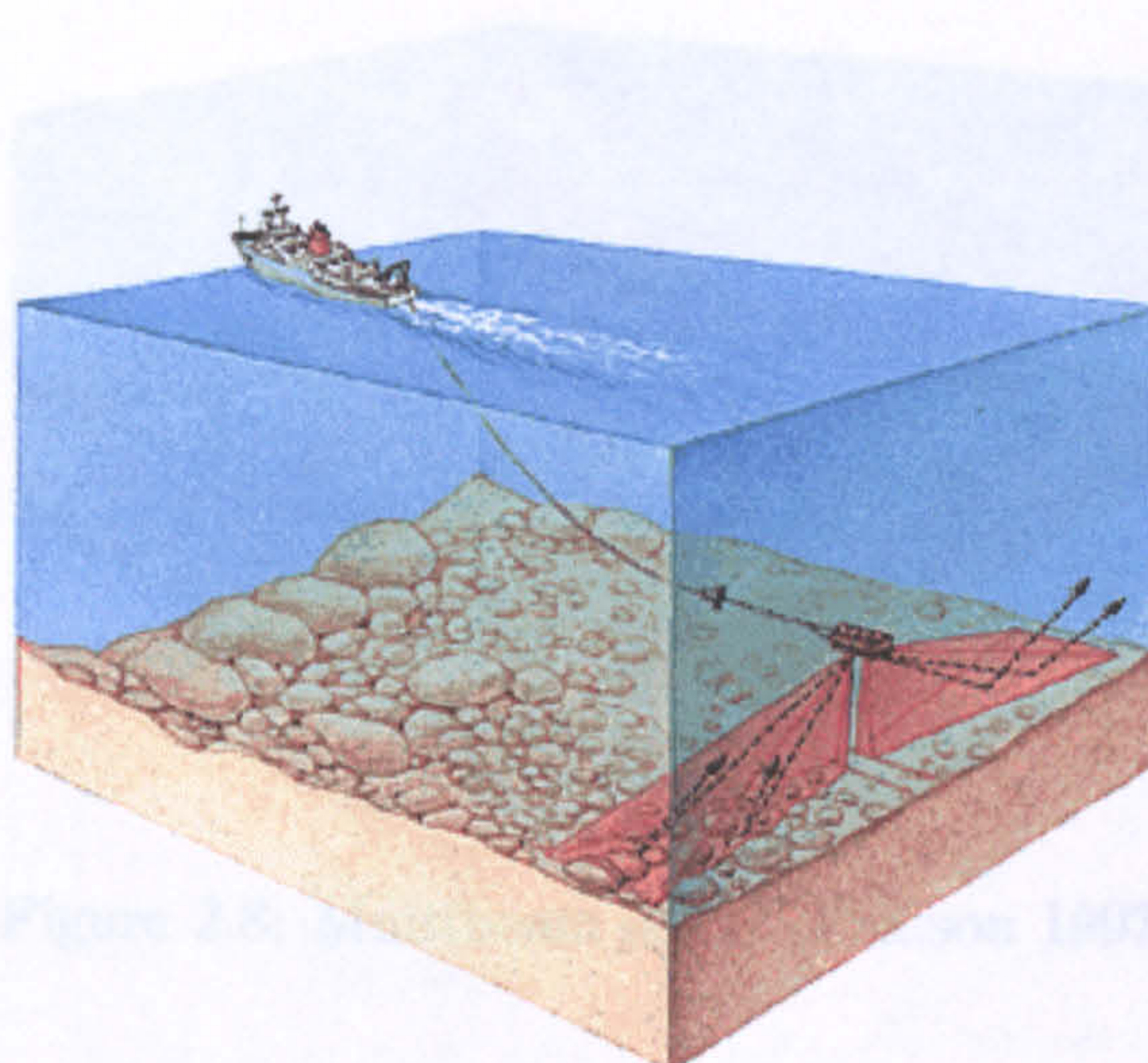

Figure 2.6: Side scan sonar (Pratson 1997)



Figure 2.7: Modern side scan sonar imaging (Fish & Carr 2000)

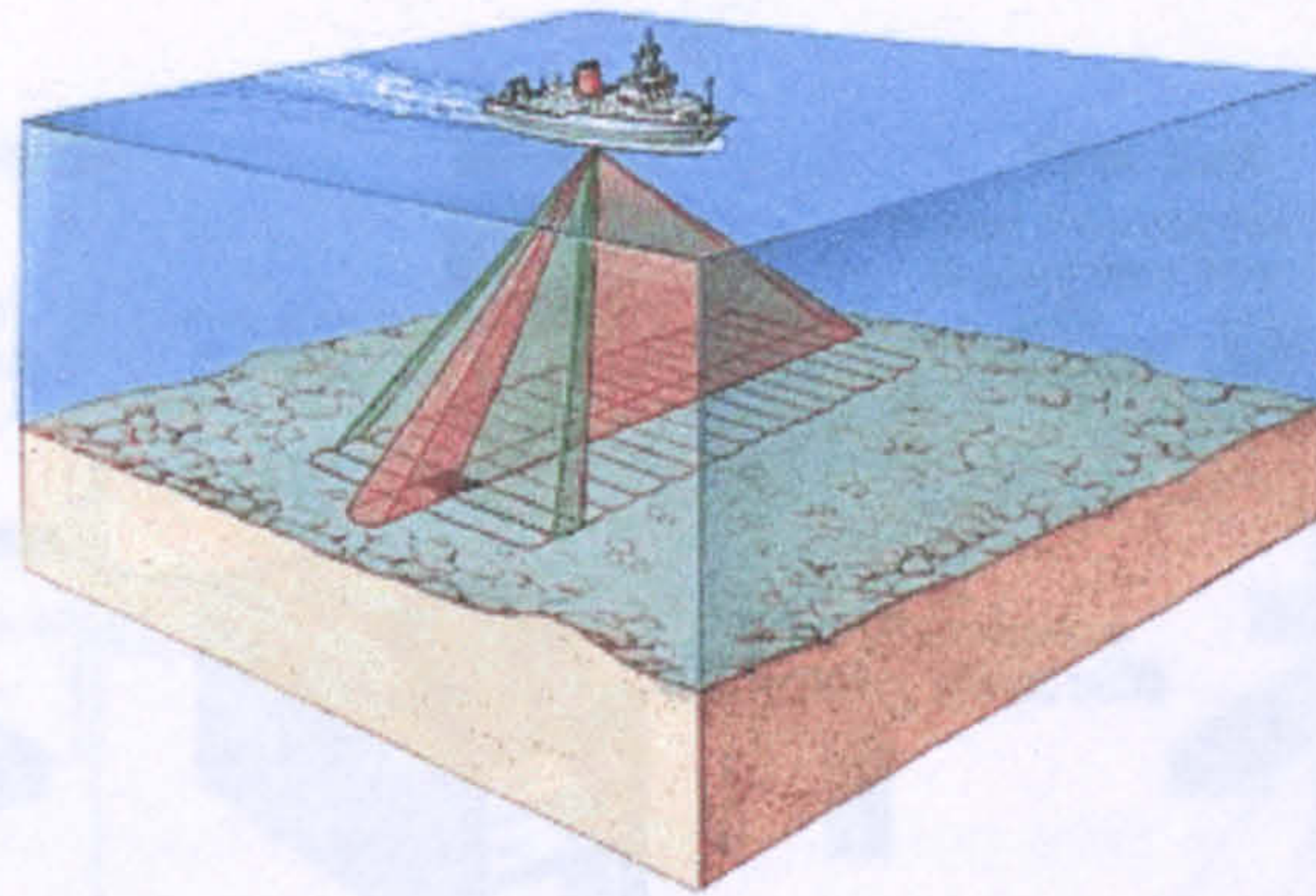

Figure 2.8: Multibeam sonar (Pratson 1997)

on the seabed off the coast of Chile, South America (Fish & Carr 2000). The image was captured using a DF-1000 digital towfish. Digitising the image allows specific colours to be applied to varying amplitudes. For example in Figure 2.7 the shadows have been negated so that they are black as opposed to the traditional paper white shadows that can be found in conventional paper displays.

Multibeam Sonar

Multibeam sonar reflects sound off the seafloor to determine ocean depth as opposed to measuring the amplitude of the returned signal used in side scan sonar. In contrast to echosounders, this technique uses an array of sound sources and listening devices mounted on the hull of the survey vessel as shown in Figure 2.8. Every few seconds the sources emit a burst of sound energy that reaches only a slim strip of seafloor aligned perpendicularly to the direction that the ship is moving (Pratson & Haxby 1997).

At the same time the listening devices begin recording the reflected sound from the seabed. This equipment is arranged to detect sounds specifically emanating from within a series of narrow seafloor corridors aligned parallel to the ship's direction. The sound reflections received at the ship emanate from seabed regions where the strip of transmitted sound and the listening corridors overlap. The timing of these reflections provides a profile of seafloor depth and by recording such profiles every few seconds allows a survey ship to build up a continuous swath of coverage along the ship's track. Multibeam sonar can therefore provide 3D images of the seabed.

2.6 Marine Data Acquisition Methods

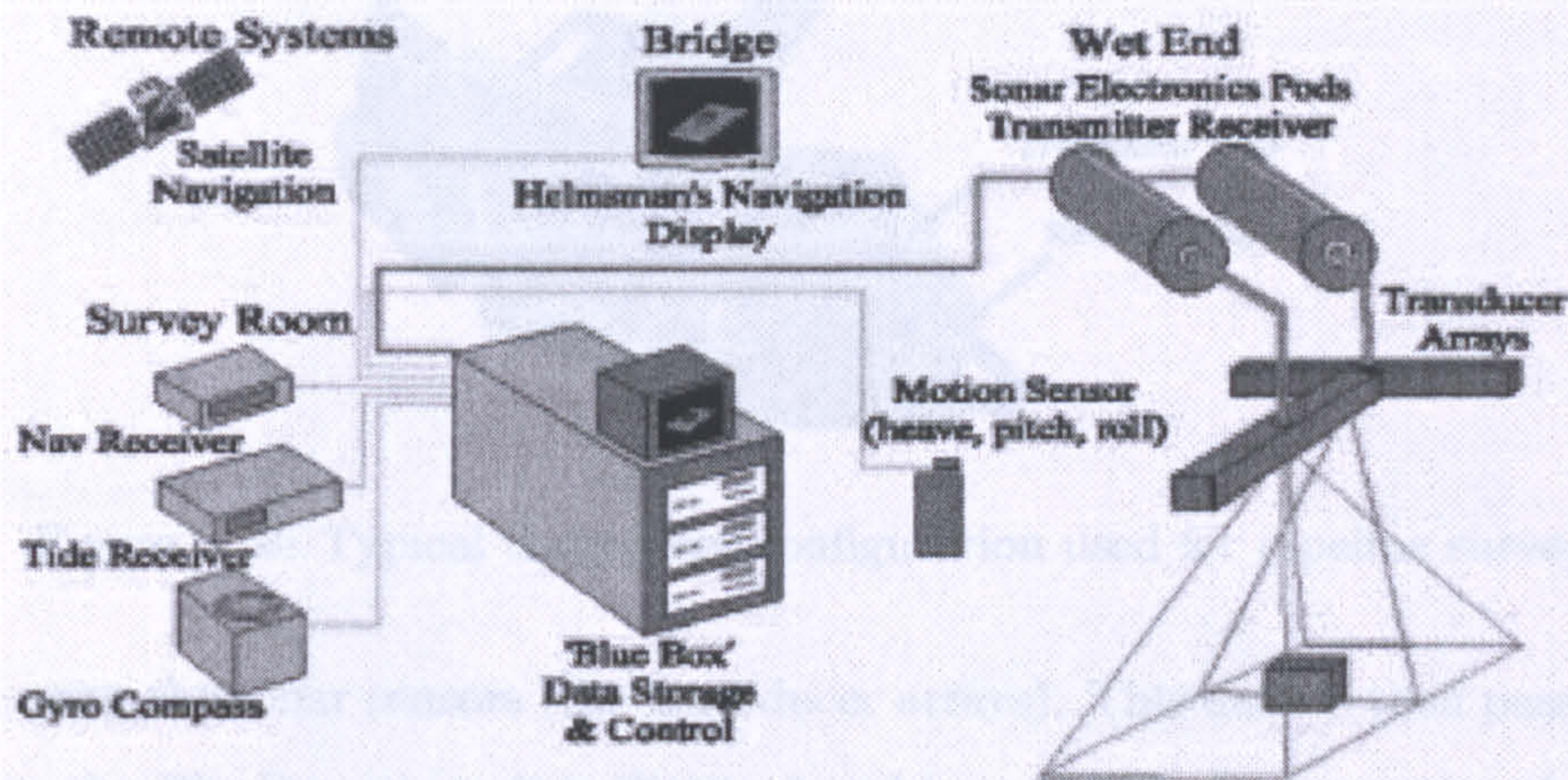

Figure 2.9: SRD's SVS Sonar Architecture (SRD 1997)

Forward Looking Sonar

Forward Looking Sonar (also known as ahead-look scan) is another sonar system configuration not too dissimilar to the side scan system already described above. Forward looking sonar is commonly hull-mounted and is used for obstacle detection or avoidance and imaging. Forward looking sonar has also been used for rendezvous positioning in submersibles and for mine detection. This sonar technique is imperative for many ROV operations, especially those conducted in poor visibility where video cameras prove to be ineffective.

Swathe Bathymetry

This section describes how a swathe bathymetry system works. SRD Ltd has developed a high-speed multi-frequency continuous scan sonar that implements a single sweep system that collects high-resolution bathymetric data. The original multibeam sonar consists of an array of single beam echo sounders, all transmitting and receiving at the same time and each pointing in a separate direction. A multibeam echo sounder may contain 60 beams, each with a beam width of 3 degrees, covering a sector of 90 degrees. The seabed visualization system (SVS) is a continuously scanning swathe system. This differs from a multibeam system in that the transmit pulse illuminates a thin strip of seabed using a single shaped beam.

SRD's SVS architecture can be seen in Figure 2.9. Initially the raw sonar data is

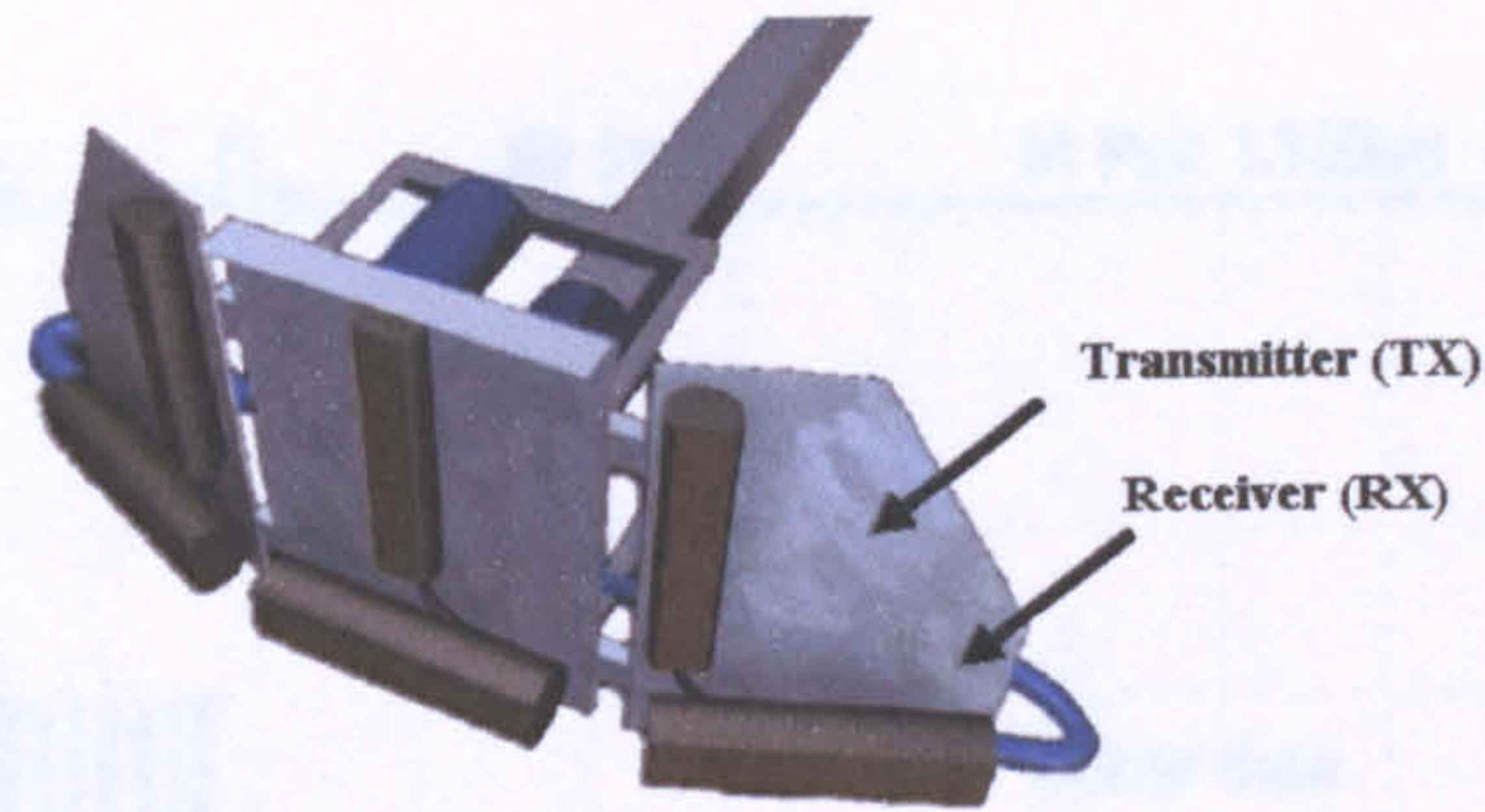

Figure 2.10: Typical transducer configuration used for pipeline survey

gathered using the sonar sensors (the transducer arrays). This data is then passed through the Pod to the BlueBox where it is digitised and logged. The Pod contains the necessary electronics for controlling the transducers and receivers, acting as an intermediary between the sonar sensors and the BlueBox.

The BlueBox shown in Figure 2.9 is the nucleus of the SVS data acquisition operations. It contains three computers: a Map, Scan and Pos (Positional) PC, each with dedicated responsibilities discussed below.

The Raw Sonar Image

The SVS sonar system consists of a transmitter (transducer - Tx) and a receiver (hydrophone - Rx). A typical configuration for the transducers is shown in Figure 2.10. The transmitter and receiver each consist of 36 piezoelectric elements. The transmitter emits an acoustic echo at a definable frequency: 80kHz, 150kHz, 240kHz or 300kHz. The transmitter works by emitting a pulse of sound that lasts for $100\mu\text{s}$. The Scan PC controls the pulse length frequency of the transmitter.

The user sets the required parameters on the Scan PC which sends the control commands via a serial cable to the Pod. The Pod processes these commands and configures the transmitter to the user specification.

The receiver is electronically controlled, and is continuously scanning from left to right to detect acoustic returns. Each left to right scan takes exactly $100\mu\text{s}$. The receiver will eventually detect the transmitted sound reflected off the seabed. Each of the 36 piezoelectric elements in the receiver correspond to a channel in the Pod. The Pod sums its channel inputs to produce a phase shift for the received acoustic echo. The summing algorithm enables the

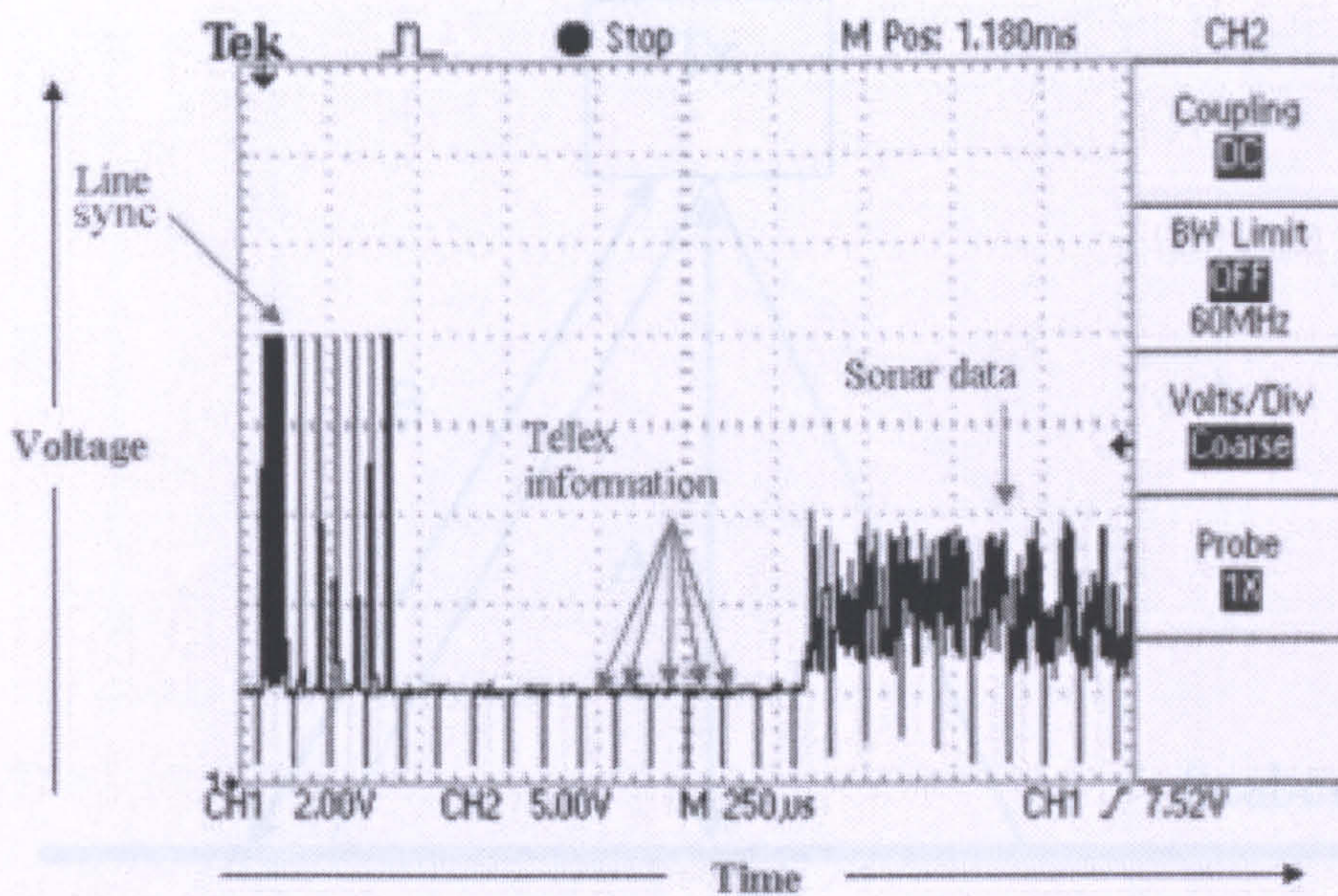

Figure 2.11: POD analogue video signal

The video signal contains three pieces of combined information:

1. Line-sync (between 0 and 2 volts).
2. Sonar data (between 2 and 8 volts).
3. Telex information (between 8 and 12 volts).

The teletext information contains the Pod’s current configuration. When no echoes are being received the data signal is flat. As soon as the hydrophone detects returned signals from the seabed, voltage fluctuations are received on the data channel. Figure 2.11 shows a graphic of the analogue video signal captured from a digital oscilloscope.

The Scan PC then dissects the analogue video signal apart into its three source components. The Scan PC software digitises the incoming data signal from the Pod and the digitised sonar echo is displayed as a range/bearing graph. Figure 2.12 and Figure 2.13 show the range and bearing parameters and the pattern that is received from a downward

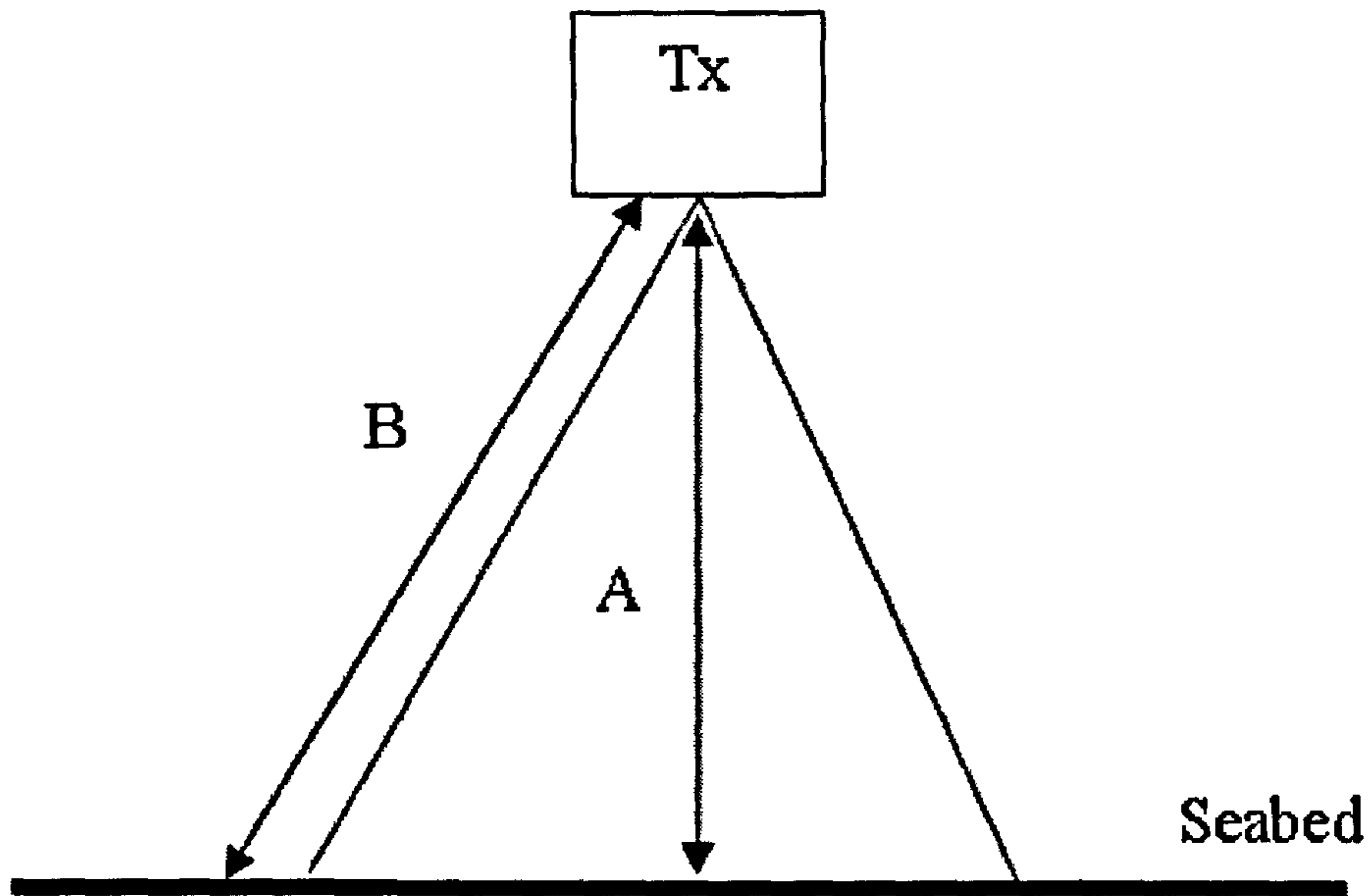

Figure 2.12: Range Bearing Parameters

looking sonar. The display is curved because the distance to the seabed is greater at the scan limits than the midway point 'A'.

The following positional data is received by the Pos PC:

1. Ship's position from positional systems (normally GPS).
2. Heave, pitch and roll data from the ship's motion sensors.
3. Tide data sent from a tide gauge.
4. Heading information from the ship's gyro compass.
5. Any auxiliary information needed for the survey.

The software on the Pos PC calculates the precise position of the vessel based on these input streams. The Pos PC then sends the position and timing information to the Scan PC. The digitised display points from the Scan PC are then sent along with all the positional data from the Pos PC to the Map PC. The Map PC calculates the real world co-ordinates of the echo and provides the survey team with corrected scans and sensor data plots. The Map PC also handles all the operational logging facilities. When logging is switched on, three different types of file are created:

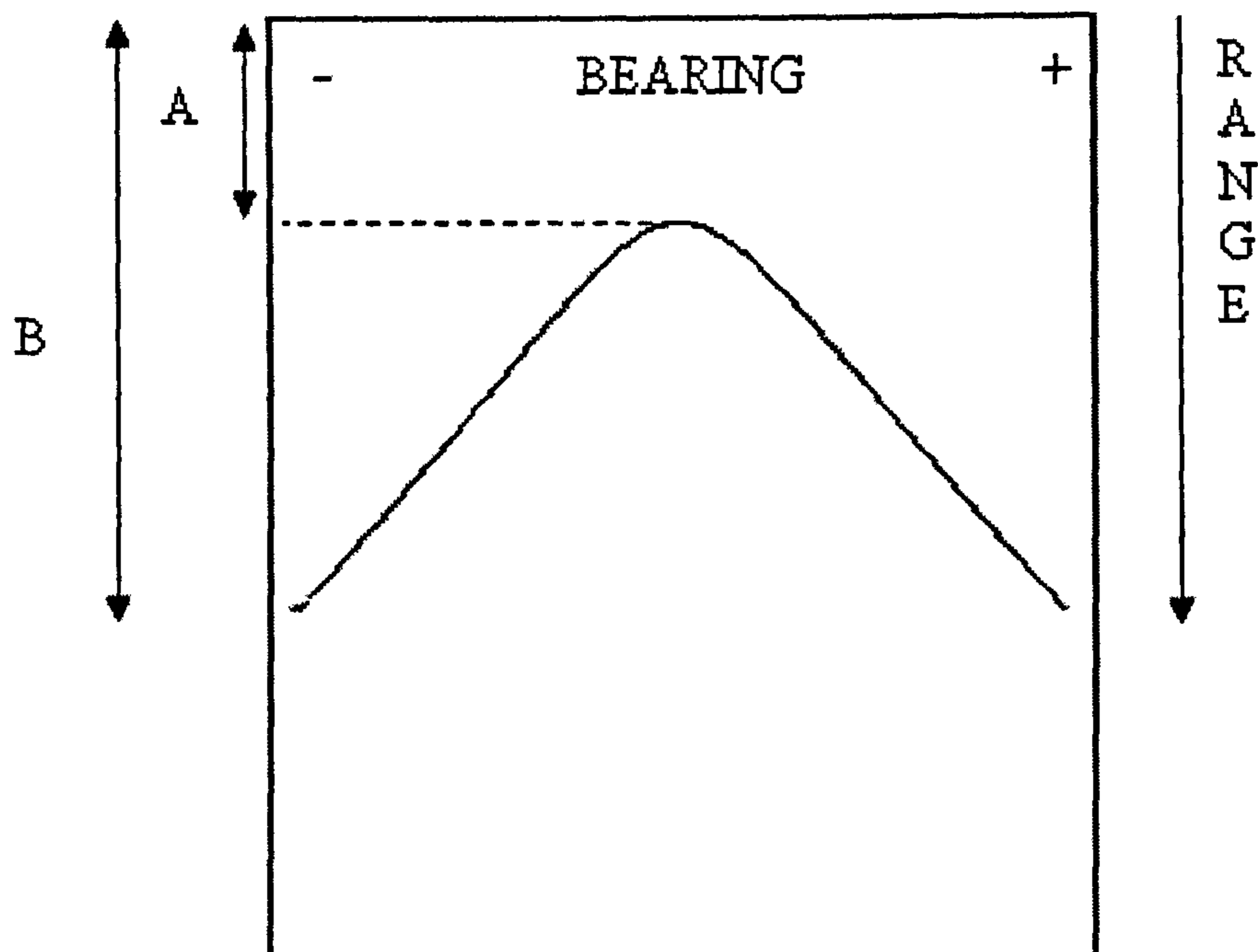

Figure 2.13: A flat seabed pattern received from downward looking sonar

1. RSD Raw Sensor Data.
2. RPD Raw Ping Data.
3. DTF Digital Terrain Files.

The raw sensor data files are ASCII files containing raw sensor data and timing relationship information. The raw ping data files are compressed binary files containing the raw data from the Scan PC in range and bearing coordinates along with all the sensor information from the Pos PC. The DTF raw data files are the primary input used for marine visualization in later chapters.

2.7 Evaluation of Acquisition Techniques

Table 2.2 provides a summary of the various techniques available for gathering submarine terrain data considered in this chapter. Each row describes a data acquisition technique's speed and accuracy (0-5max) and suggests whether such a technique is applicable to each

2.7 Evaluation of Acquisition Techniques

Acquisition	Accuracy	Speed	Shipwreck	Pipeline	Route	Dredging	Debris
Satellite	1	5	×	×	×	×	×
Photography	4	3	✓	✓	✓	✓	✓
Lidar	2	5	×	×	×	×	×
SBP	4	3	×	✓	✓	✓	×
Side scan	5	5	✓	✓	✓	✓	✓
Bathymetry	5	5	✓	✓	✓	✓	✓

Table 2.2: Evaluation of the speed and accuracy of various survey techniques and their applicability to a variety of offshore activities

of the five offshore activities described earlier. Note that the accuracy of the system is measured in terms of accuracy relating to small offshore surveys and not global surveys (such as mapping continental margins (Pratson & Haxby 1997)).

It is rare that a single acquisition method is used for an entire survey and the author's experience in the field has shown that survey techniques will often complement each other. For example, a side scan survey may be used to locate a ship wreck and an ROV would then be used to gather high resolution video data from the wreck. Another example would be the use of a SBP for the precise location of a buried pipeline coupled with a side scan or swathe bathymetry survey to gather terrain and exposed pipeline data. It is not therefore feasible to apply a single marine acquisition technology across all offshore activities.

Considering the applicability of survey techniques shown in Table 2.2, it can be seen that side scan sonar and swathe bathymetry are the most effective acquisition techniques over all five offshore activities⁷. Swathe bathymetry has been chosen as the main form of data acquisition within this thesis due to the system's ability to capture true bathymetric data enabling 3D rendering of the seabed which is a focal point within this thesis (side scan does not return 3D bathymetric data).

However, due to the complementary nature of the survey techniques described above⁸, research will also consider the visual integration of different forms of survey data.

⁷The author has also noted that these two surveying techniques are among the most popular technologies on show at the annual Oceanology trade fairs held in Brighton and Singapore.

⁸For example, a SBP will complement a bathymetric survey when performing a pipeline survey.

2.8 Summary

This chapter has introduced some characteristic offshore activities and has considered the various techniques used for gathering data relating to seabed topography. Sonar imaging techniques were considered in detail focussing on a continuously scanning swathe system (SRD's SVS marine visualization system). This system will be the main form of data acquisition used within this thesis as this chapter has evaluated it as the most applicable data acquisition technique for the characteristic offshore activities described previously.

This thesis will investigate if informed decisions and insight into the collected data can be improved with effective 3D visualization of the bathymetric data collected from a swathe bathymetry sonar system. Chapter 3 introduces the reader to this relatively new science of visualization and introduces a visualization pipeline that will be used in later chapters for supporting a marine visualization architecture.

Chapter 3

Visualization

Visualization is concerned with exploring data and information graphically as a means of gaining understanding and insight into data. Visualization systems transform data or information into pictures for our eyes which are the primary human sensory apparatus. It has been estimated that around fifty percent of the brain's neurones are associated with vision (McCormick, DeFanti & Brown 1987). Visualization aims to put that neurological apparatus to work.

Visualization was first recognised as a formal discipline in the 1987 NSF report Visualization in Scientific Computing (McCormick et al. 1987). In recent years, the field of visualization has grown enormously with major conferences dedicated to this area, such as the IEEE Visualization (IEEE 2000) and ACM SIGGRAPH (ACM 2002).

Brian Collins provides a historical review of visualization in his paper: Data Visualization - Has it all been done before? (Collins 1993). Visualization is not a new subject and scientists have been using the 'visual process' without the aid of computers for centuries. Collins states that in 1686, the famous English astronomer, Edward Halley, was reducing large amounts of numerical data such as mortality tables and meteorological data into meaningful charts and representations. In fact, as long ago as 1637, the French Philosopher, Rene Descartes was reporting on the crucial role that diagrams play in scientific investigation (Collins 1993).

Collins suggests that the first probable use of computer graphics for visualizing data was the SAGE air defence system developed in 1949, with the first installation in 1958. The system processed radar data and displayed aircraft movements on a cathode ray tube.

Recent visualization techniques were developed as a reaction to coping with the vast



3.1 Visualization Reference Models

quantity of data being generated in science during the mid 1980s. These ‘fire hoses of data’ (McCormick et al. 1987) were generated by systems such as super computers, orbiting satellites returning large quantities of data such as weather data, spacecraft sending planetary and interplanetary data and medical scanners employing various imaging techniques.

Present day scientific and engineering investigators are confronted with research problems that depend on gaining insight into complex and voluminous data. Immediate visual feedback of the data (which cannot be comprehended by the brain in its numerical format) can help researchers gain insight into scientific processes and abnormalities.

3.1 Visualization Reference Models

A reference model is a standard for imitation and comparison and provides a pattern on which to base an artifact (Duce & Hopgood 1990). A reference model can offer a common terminology which is unambiguous and provides the ability to distinguish and describe different modes of working within a common framework. This chapter introduces two reference models for the visualization process that will be used to facilitate discussions and comparisons of marine visualization systems in later chapters.

3.1.1 Upson et al’s Reference Model

In 1989, a number of scientists from Stellar Computing wrote an article describing a software system for developing interactive scientific visualization applications (Upson, Jr, Kamins, Laidlaw, Schlegel, Vroom, Gurwitz & VanDam 1989). Their Application Visualization System (AVS) was designed around the concept of software building blocks that could be interconnected to form visualization applications.

Their software allowed flow networks of existing modules to be connected using a simple user interface. The connected modules defined a ‘visualization pipeline’ where raw data could be transformed through a series of modules into an image. Their AVS visualization system was built around this architecture (Figure 3.1) and was the first true modular visualization environment incorporating the dataflow pipeline.

The Filter, Map and Render functions (shown in Figure 3.1) can be explained by considering an example visualization of seabed topography where raw data gathered from a sonar system needs to be visualized.

3.1 Visualization Reference Models



Figure 3.1: Upson et al. Visualization pipeline

Filter

Data of interest are derived from the raw sonar data, for example, an interpolation of scattered data onto a regular grid such as a digital terrain map (DTM) (an elevation grid for the survey area).

Map

The map process converts the DTMs into geometric primitives which can be rendered, for example, a polygon mesh based on the spatial data stored within the terrain maps. Each polygon is constructed from data points within the DTM and each polygon may be textured or coloured.

Render

The final process involves rendering the mapped data into pictures.

3.1.2 Haber and McNabb's Reference Model

Just a few months after Upson et al's publication, at the 1990 IEEE conference on Visualization, Robert Haber and David McNabb presented their much cited conceptual model for scientific visualization (Haber & McNabb 1990). They described a similar pipeline system to Upson et al yet proposed a data driven model as opposed to the process driven architecture proposed by Upson et al.

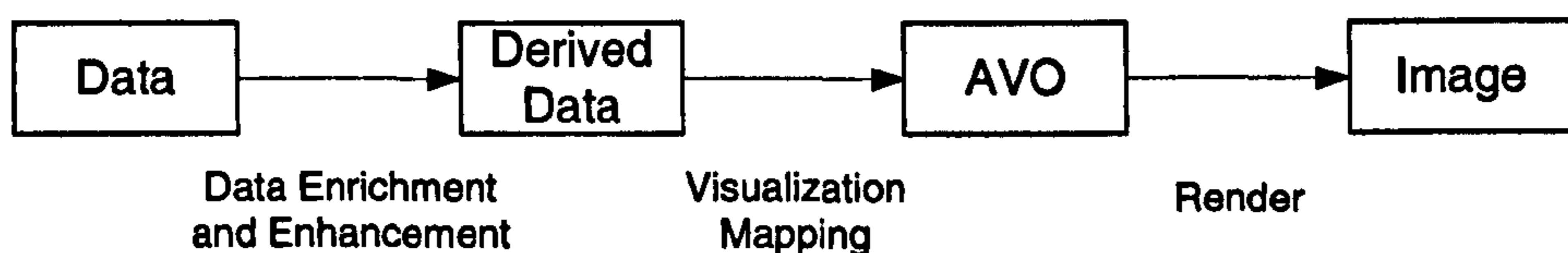

Figure 3.2: Haber & McNabb Visualization pipeline

Haber and McNabb identified three processes in the visualization pipeline (Figure 3.2.)

3.1 Visualization Reference Models

Data enrichment / enhancement, visualization mapping and rendering. These three processes equate to Upson et al's Filter, Map and Render. The AVO or Abstract Visualization Object describes an imaginary object in time and space that is the result of the previous visualization mapping.

3.1.3 User Feedback

The visualization models described above are very similar and are often treated as the same model. However, one important element is missing from both models: user feedback. Visualization is a cyclic process (Brodie, Carpenter, Earnshaw, Gallop, Hubbard, Mumford, Osland & Quarendon 1992) and user feedback is essential to permit exploration of the data. Later visualization reference models incorporated user feedback (Osland 1992) (Card, Mackinlay & Shneiderman 1999) but increased in complexity.

This thesis adopts the Upson et al model described previously but extends the model by providing user feedback into the processes as shown in Figure 3.3.

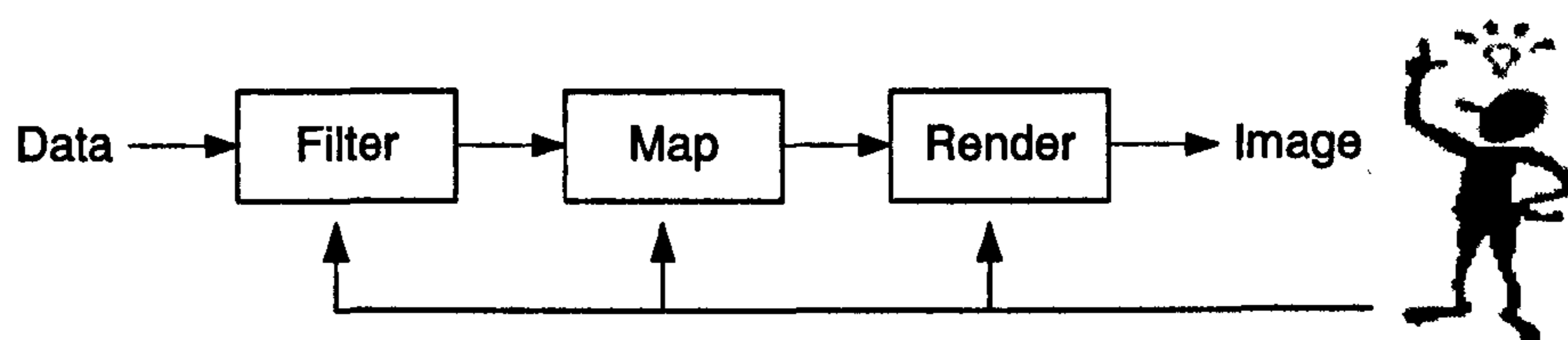

Figure 3.3: Haber & McNabb model with added user feedback

It is now possible for the user to modify parameters at all stages within the visualization pipeline. Returning to the seabed visualization example, user feedback for each of the filter, map and render processes can be considered. Filter parameters can be modified to improve the removal of 'spikes' from the raw data resulting in better quality terrain maps. Modifications to the Map process may involve modifying a colour palette used to represent the different depths on the seafloor (hypsonetric hints). Scrolling the palette enables seabed anomalies to be identified quickly. Modifying render parameters may involve changing camera or eye positions to look in more detail at an area of interest on the seabed, for example, clay ridges or deep scour marks on the sea floor.

3.2 Categorising Visualization Systems

Over the last 20 years, visualization systems have generally evolved into two categories: Turnkey and Modular Visualization Environments (MVEs).

3.2.1 Turnkey Visualization Systems

Turnkey visualization systems provide a fixed set of visualization techniques to the investigator. The investigator does not have the freedom to alter the techniques provided, but does have the advantages associated with the software coming from one source. Since everything is under their control, the supplier has the opportunity to produce a package that is efficient and responds to the needs of particular applications.

The major disadvantage with turnkey systems is that the facilities provided are finite, yet requirements for visualization systems can be extremely diverse. The advantage of turnkey systems is that they are generally low cost. Examples of turnkey systems are Data Visualizer (Wills 2001) , PV Wave (Numerics 2001), Uniras Interactive Programs (Thirugnanasothy 2001) and Spyglass (Spyglass 2001).

3.2.2 Modular Visualization Environments

Modular Visualization Environments (also known as Dataflow systems and Application Builders) are powerful visualization systems that allow the investigator to control the flow of data through a network of processing modules. Each module is represented as a graphical object called a glyph and is generally dedicated to a filter, map or render process. These glyphs are connected together to produce the visualization pipeline required for a specific visualization. MVEs share a number of features:

- **Modular Approach.** Modules can be selected and combined by the investigator for a particular visualization task.
- **Network.** A network of modules may be composed by using a visual interface.
- **Extensible.** A large number of modules are provided by the system and others can be added by the investigator.

3.3 Summary

Examples of MVEs include AVS (Lord 1995), IRIS Explorer (Foulser 1995), IBM Data Explorer (Abram & Trenish 1995) and Khoros (Young, Argiro & Kubuca 1995).

MVEs are more popular than turnkey systems with today's scientific community although they generally have a steeper learning curve and are more expensive than their turnkey counterparts.

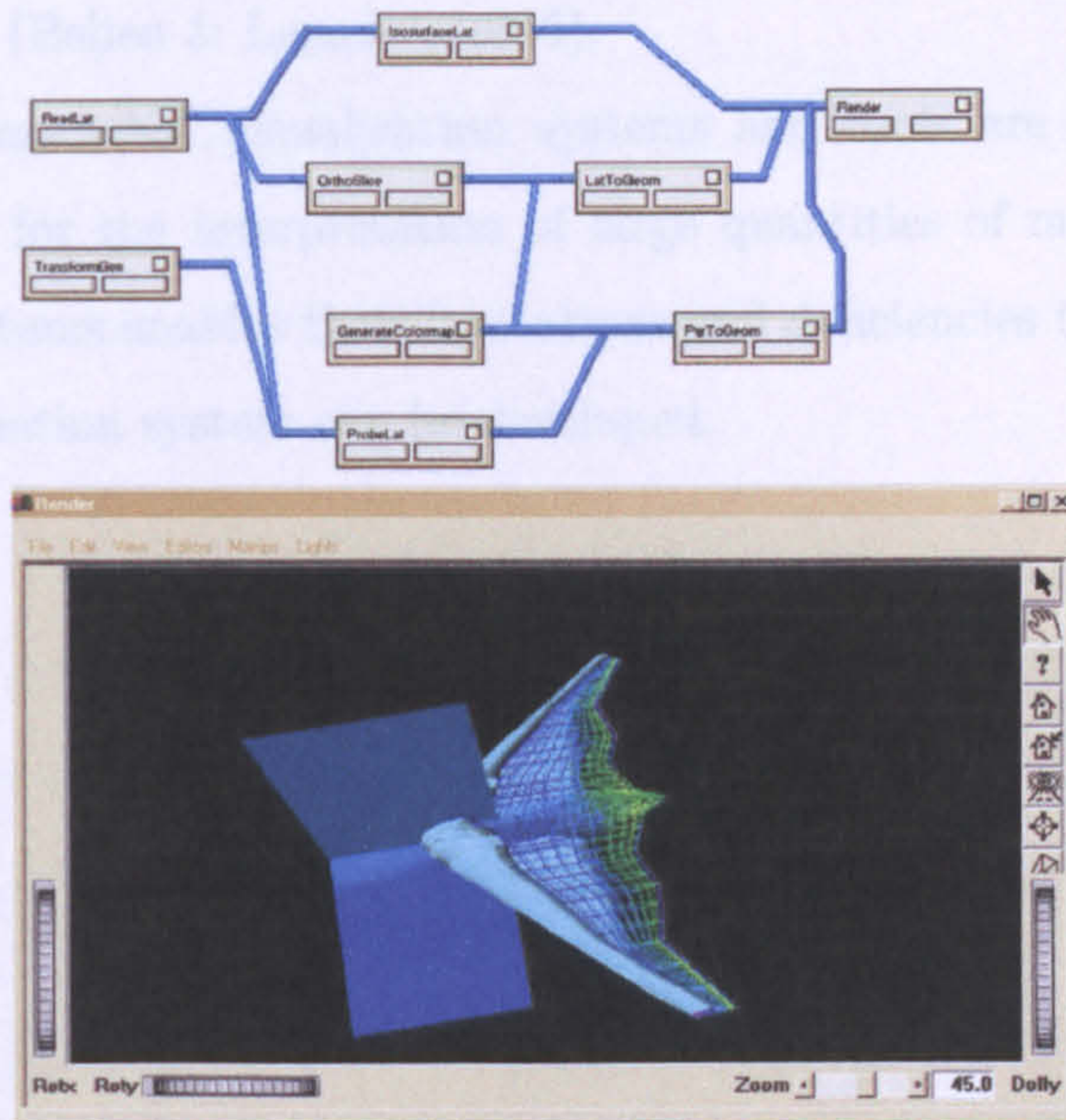

Figure 3.4: IRIS Explorer

Figure 3.4 shows a snapshot from the IRIS Explorer toolkit. Note the visualization pipeline in the top half of the diagram defining the flow of data for the visualization. The bottom half of the diagram shows the final rendered output (which is the final module on the right of the visualization pipeline).

3.3 Summary

Visualization is concerned with exploring data and information graphically as a means of gaining understanding and insight into data. Visualization systems provide the facilities to display and interrogate the data in a format that effectively utilises the large processing bandwidth of our eyes and brain.

This chapter has described a popular reference model for the visualization process proposed by Upson et al and Haber and McNabb. Their filter, map and render pipeline will be

3.3 Summary

used as an implementation model to support later discussions of marine visualization data flow systems.

More information on visualization systems can be found in 'The Advisory Group on Computer Graphics' (AGCG) (Brodie, Gallop, Grant, J.Haswell, Hewitt, Larkin, Lilley, Morphet, Townsend, Wood & Wright 1995) and 'SARA Comparison of Visualization Techniques and Packages' (Belien & Leenders 1995).

Chapter 4 considers what visualization systems and tools are currently available to the offshore engineer for the interpretation of large quantities of marine data. A critical appraisal of these systems enables their limitations and deficiencies to be identified so that a new marine visualization system can be developed.

Chapter 4

Seabed Visualization Systems Review

This chapter proposes a set of essential and desirable characteristics required in a seabed visualization system (hereby referred to as SystemX). These characteristics have been selected based on a knowledge of the visualization process (Chapter 3) and the offshore industry (Chapter 2). Contemporary marine visualization systems are then evaluated against these criteria.

The chapter concludes by broadly describing some high level requirements for a new offshore marine visualization system which have been constructed based on the shortfalls of today's visualization tools and the essential and desirable characteristics proposed in this chapter. These high level requirements provide the initial building blocks for the subsequent chapter on system architecture.

4.1 Essential and Desirable Requirements for an Offshore Marine Visualization System

This section describes four desirable requirements and characteristics for a marine visualization system. These characteristics have been selected based on a knowledge of the offshore industry and the visualization process where computer graphics are used to facilitate the user's comprehension of large complex datasets.

4.1 Essential and Desirable Requirements for an Offshore Marine Visualization System

4.1.1 3D Rendering

Datasets gathered from offshore surveys are physically based and are already naturally defined spatially in three dimensions¹. The first desirable characteristic for SystemX is to take advantage of the human brain's powerful spatial processing ability (McCormick et al. 1987) in order to facilitate the interpretation of data by providing data in as natural a viewing environment as possible. Data abstractions will be permitted but the dimensionality of any visualizations should equate to the dimensionality of the original survey.

4.1.2 Visualization and Interaction with Multiple Datasets

The wide variety of hardware used offshore and the inherent complexity of offshore operations results in numerous datasets being produced from a single survey. Chapter 2 described some typical offshore activities and identified a large variety and quantity of generated data. For example, a pipeline survey (Section 2.2) may produce ROV video footage, bathymetric, side scan and sub-bottom-profile data. Consequently, even a simple offshore activity can result in the collection of large amounts of multi-dimensional data that must all be interpreted.

A desirable characteristic for an offshore marine visualization system (and the second requirement for SystemX) is the seamless integration of multiple and disparate data into a single and succinct user interface that provides a unified database of information. Typical user interaction with the pipeline survey data described above should provide the user with visual interpretations of 3D bathymetry, 2D side scan sonar images, sub-bottom-profile data, ROV video footage and numerous positional information (all within a single interface).

4.1.3 Real-time 3D Visualization of Offshore Activities

The offshore activities described in Chapter 2 described a range of tasks that varied quite significantly in complexity. For example, a survey may require the simple gathering of bathymetric data for a shipwreck and surrounding area. The data would not necessarily be required for visualization and interpretation on the job (except for verification that the data was being collected correctly) as the data would be analysed post-survey in the

¹The fact that spatial scientific data is being visualized links offshore marine visualization to scientific visualization rather than the more abstract renderings associated with information visualization. Either way, marine visualization is planted firmly in both sciences albeit with deeper roots in the scientific domain.

4.2 Review of Contemporary Marine Visualization Techniques

office. These visualizations can be defined ‘post-survey visualizations’. Chapter 2 described more complex surveys that might include many complex operations executing in parallel. SystemX should not only provide post-survey static visualizations but should also have the potential to provide the viewer with real-time 3D rendering of complex offshore activities. It is feasible that real-time intuitive 3D visualizations could improve the viewer’s spatial awareness and understanding of complex (and dangerous) offshore work environments.

4.1.4 System Flexibility

Chapter 2 also highlighted the diverse nature of activities faced by the offshore industry. Consequently, the system must be constructed using a modular architecture in order to provide a generic visualization tool for all offshore visualization problems.

The SystemX architecture should allow the user to effectively tailor the marine visualization tool to a specific task permitting the user to move away from static turnkey marine system architectures. A flexible modular architecture would enable the user to plug various modules together resulting in a problem specific pipeline architecture such as the MVE systems described in Chapter 3.

The above requirements have highlighted a number of characteristics for an ideal marine system (SystemX). These include the ability to render a marine environment in 3D based on the integration of multiple datasets with real-time visualization possibilities. An adaptable flexible system is also desirable given the diverse nature of requirements within the offshore industry. Other less essential requirements for an ideal system would include moderate financial costs and development / training times (referred to as temporal expense).

Section 4.2 below reviews the tools currently available to offshore engineers and management in order to visualize the large amounts of data returned from offshore surveys. Each system is evaluated against the above SystemX desirable characteristics.

4.2 Review of Contemporary Marine Visualization Techniques

Although sonar has been in use since the early 1920s, it has only been recently that this data has been digitised allowing computers to process and visualize the collected data².

²Although the technology for digitising the data has been available for some time, the sheer quantity of data returned from a survey and the computing power required to process it has been the limiting factor

4.2 Review of Contemporary Marine Visualization Techniques

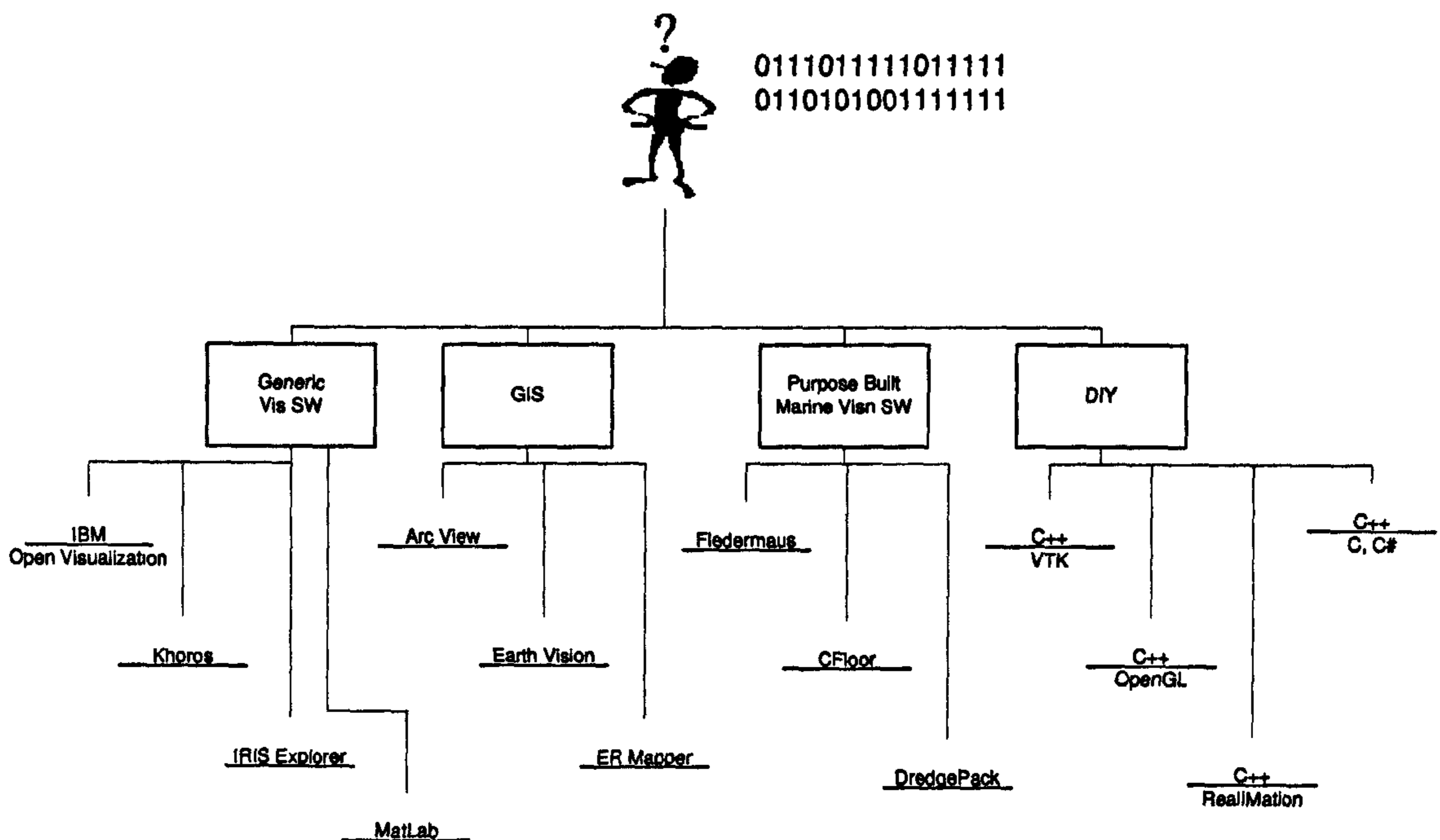

Figure 4.1: Visualization possibilities for marine data

Figure 4.1 suggests four possible approaches for the marine engineer to visualize this data: generic visualization software, geographical information systems (GIS), purpose built marine visualization software and a 'do-it-yourself' (DIY) approach. These four techniques are now considered in more detail. Each section concludes with a table that summarises each system's ability to contribute to the essential and desirable characteristics defined previously. Marks are awarded from zero (×) to three ✓✓✓.

4.2.1 Generic Visualization Software

This section considers five generic visualization tools available for the visualization of multiple marine datasets. Specifically AVS (Lord 1995), IRIS Explorer (Foulser 1995), IBM Data Explorer (Abram & Treinish 1995), Khoros (Young et al. 1995) and MatLab (MathWorks 2002).

for using computers. No longer is an 80 Megabyte hard disk and 16 Megabytes of RAM a luxury. Modern standard desktop PCs now come with hard disks measured in Gigabytes and on board memory well in excess of 256 Megabytes.

4.2 Review of Contemporary Marine Visualization Techniques

IBM Open Visualization

Data Explorer Open Visualization Data Explorer (Abram & Trenish 1995) is a visualization framework that gives users the ability to apply advanced visualization and analysis techniques to their data. These techniques can be applied to help users gain new insights into data from applications in a wide variety of fields including science, engineering, medicine and business. Data Explorer provides a full set of tools for manipulating, transforming, processing, realizing, rendering and animating data. The system allows for visualization and analysis methods based on points, lines, areas, volumes, images or geometric primitives in any combination.

Khoros

Khoros (Young et al. 1995), is an extensible visual programming environment. It was primarily designed for research in the use of visual programming as a tool for software development for scientific visualization. There are several layers of interacting subsystems, including a user interface development system (UIDS), a data exchange format and an algorithm library. The current library of over 260 routines has been developed to facilitate research in image processing, signal processing, pattern recognition, remote sensing, machine vision and geographic information systems. One major advantage of Khoros is that it is freeware.

Iris Explorer

Iris Explorer (Foulser 1995), developed by Silicon Graphics is a modular data flow programming environment. Iris Explorer provides a framework to allow a number of independent program modules, each with a specific function, to be linked together to produce powerful visualization tools. Iris Explorer is typically used for data visualization, animation, manipulation and analysis. The system was developed for scientists and engineers to create applications for displaying and analysing complex multi-dimensional datasets interactively. Figure 4.2 shows an example of Iris Explorer visualizing a marine data of a sunken shipwreck³. The visualization pipeline used to create the graphic can be seen at the top of the graphic.

³1997 Survey of the SS Richard Montgomery, Sheerness Middle Sands.

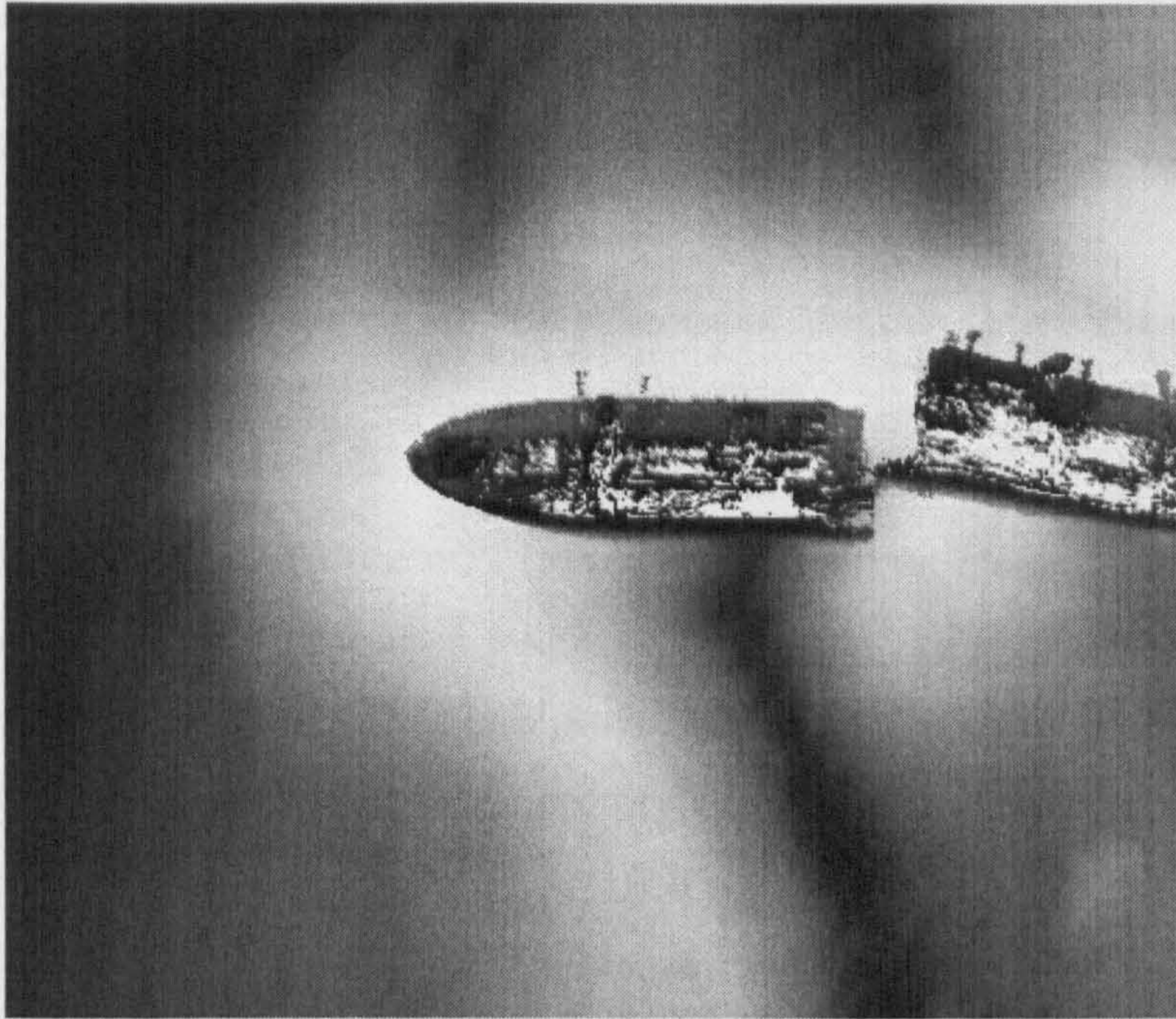
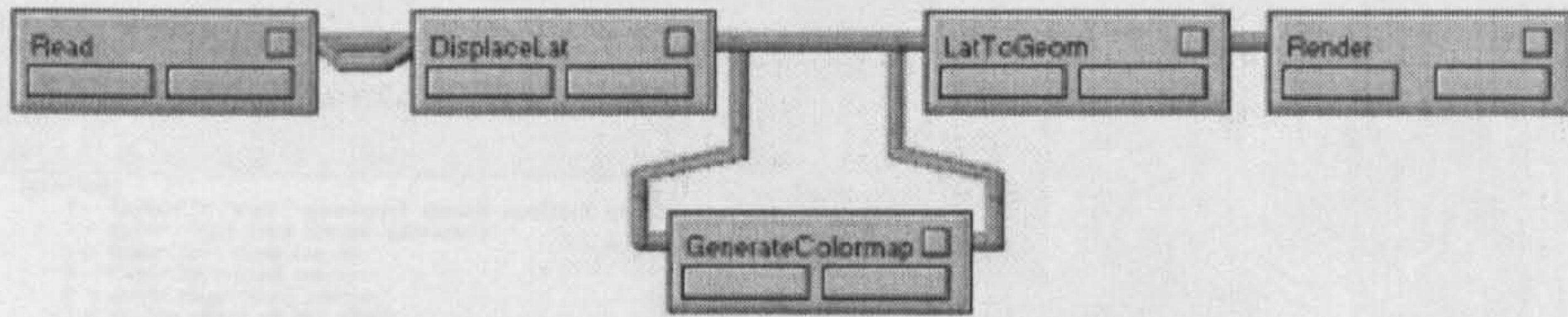

Figure 4.2: Iris Explorer visualization of the Montgomery (Courtesy of Christian Mathers, Department of Computer Science, University of Hull)

4.2 Review of Contemporary Marine Visualization Techniques

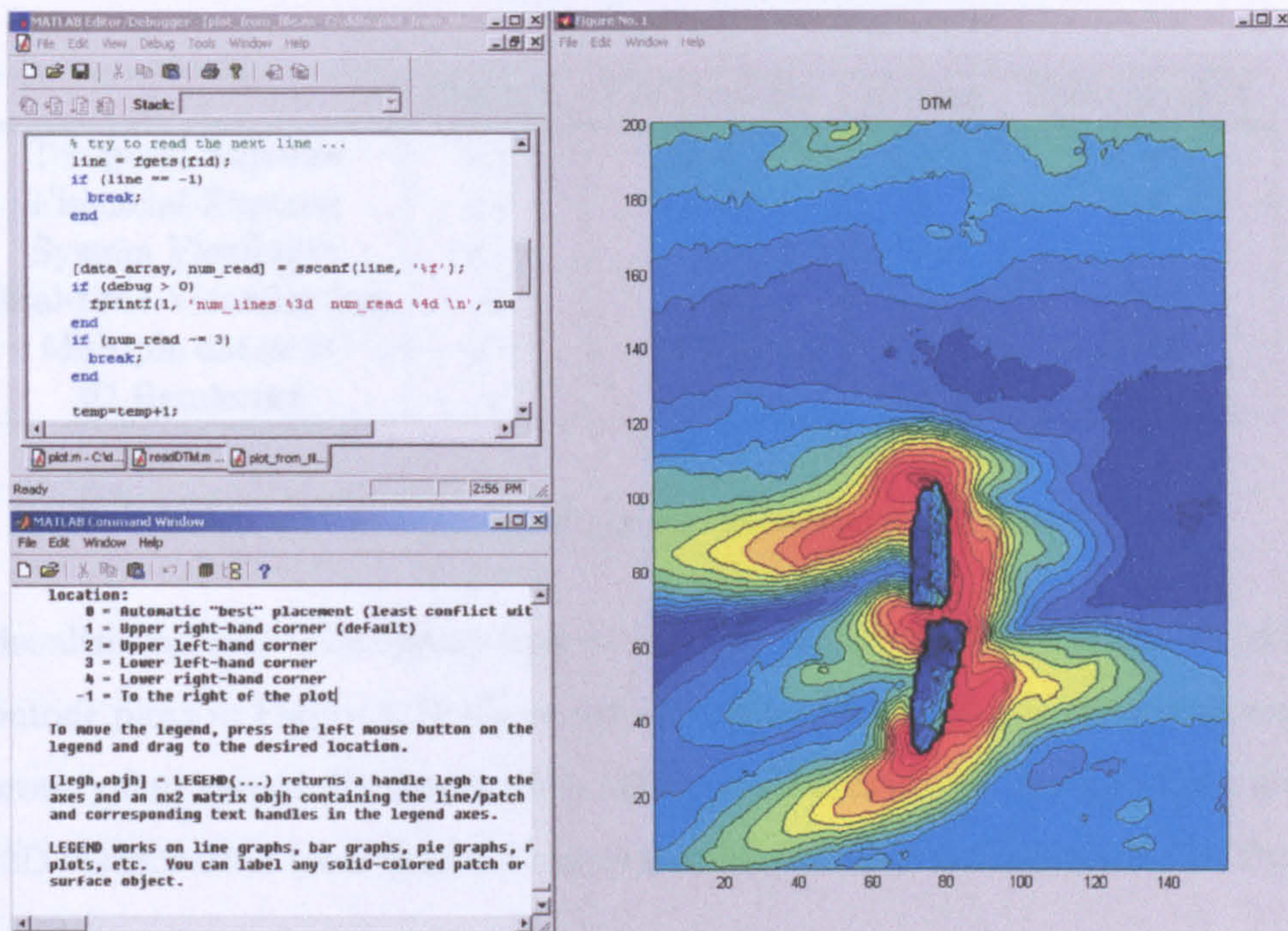

Figure 4.3: Example marine visualization using MatLab (MathWorks 2002)

MatLab

MatLab (short for MATrix LABoratory) (MathWorks 2002) integrates mathematical computing, visualization, and a dedicated language to provide the user with a flexible environment for technical computing. MatLab provides tools for data acquisition and analysis, visualization, image processing, algorithm prototyping, modelling, simulation programming and application development.

Figure 4.3, shows a typical MatLab development environment that may be used by an offshore engineer. A short program has been written to import bathymetric sonar data from the Montgomery shipwreck survey. The top left window shows the programming development environment containing the data import and rendering script. The bottom left window show a console window where the developer can execute the program and query memory content at runtime and modify display parameters such as colours and contour parameters that are rendered in the right hand window.

MathWorks's open architecture makes it easy to use MatLab for exploring and providing early insights into numerical data. However, MatLab would not be feasible as a dedicated

4.2 Review of Contemporary Marine Visualization Techniques

	MatLab	Iris Explorer	Khoros	IBMOpenDX
Temporal Expense	✓✓	✓✓	✓✓	✓✓
Financial Expense	✓✓	✓✓	×	✓✓
System Flexibility	✓✓	✓✓✓	✓✓✓	✓✓✓
Real-time Visualization	✓	✓✓	✓✓	✓✓
Multiple datasets	✓✓	✓✓✓	✓✓✓	✓✓✓
3D Rendering	✓	✓✓✓	✓✓✓	✓✓✓

Table 4.1: Evaluation of generic visualization software

marine visualization tool. The system may be used for simple visualizations (such as the 2D colour contour plots in Figure 4.3) where reduced interaction with the dataset is required, or as a prototyping system for determining effective visualizations. MatLab does not offer the true 3D visualization tools that were identified as desirable characteristics for SystemX (Section 4.1).

Generic Visualization Software Evaluation

Table 4.1 shows that the four software systems described above have the ability to render multiple datasets in 3D and in real-time although the author has been unable to locate any use of these tools within the marine industry. If these tools were used then it is most likely that they would be used specifically for 2D bathymetric post-survey visualizations such as the one shown in Figure 4.3. The main advantage of the generic visualization tools described in this section is the use of a MVE architecture resulting in a good score for system flexibility.

4.2.2 Geographical Information Systems

Geographical Information Systems (GIS) originated in the mid 1960s with Roger Tomlinson (Wright 1999) who realised that digital computers could be used effectively to map and analyse the enormous amounts of data returned from the Canadian Land Inventory. Tomlinson used the resulting statistical and cost-benefit analysis to develop management plans for large rural areas throughout the whole of settled Canada. Tomlinson called this computerisation a Geographical Information System, or GIS.

The 1970s and 1980s witnessed significant advances in the technologies used for ocean

4.2 Review of Contemporary Marine Visualization Techniques

data collection (Section 2.6) which resulted in an explosion of data and information (Wright 1999). Appreciating the potential of GIS for the marine industry, an American oceanographer in collaboration with a software engineer from Dynamic Graphics, Inc., published in 1990 one of the first articles on the potential of marine GIS (Manley & Tallet 1990).

The transition of GIS from land to marine applications has been extremely slow despite its great potential (Wright 1996). In the early 1990s, most GIS applications were land based, consequently dictating the path for GIS development (Wright 1999). However, GIS marine academics discovered the potential for GIS specific to their field and consequently advised the GIS developers encouraging them to increase the functionality of their products for the new market users.

In 1992, Gerald Hatcher wrote the first known American graduate thesis in marine GIS (Hatcher 1992), leading to a Master of Science degree in Ocean Engineering. In 1994, Dawn Wright wrote the first doctoral dissertation on marine GIS (Wright 1994), which led to a joint degree in physical geography and marine geology. An example GIS system, 'ArcView' is described below.

Real-time marine GIS

Real-time marine GIS is defined as the use of GIS technology during the collection of oceanographic data or data indirectly related to the survey (Hatcher 1999).

Gerald Hatcher, provides two prime examples of real-time marine GIS. The first example uses the continual transmission of a navigation stream for positioning a vessel icon that moves dynamically on the GIS display in correct geographical relation to other data. The second example involves a situation where new data, possibly with preliminary interpretation from an earlier part of a cruise, are added to a GIS database at sea, which is then used to guide and update the remainder of the cruise. Navigation is probably the most useful real-time data to visualize in a real-time GIS marine environment. A typical GIS navigation display can be seen in Figure 4.4. Until recently, end users had to either write their own software or use simpler methods such as updating a marker on a map (Hatcher 1999).

4.2 Review of Contemporary Marine Visualization Techniques

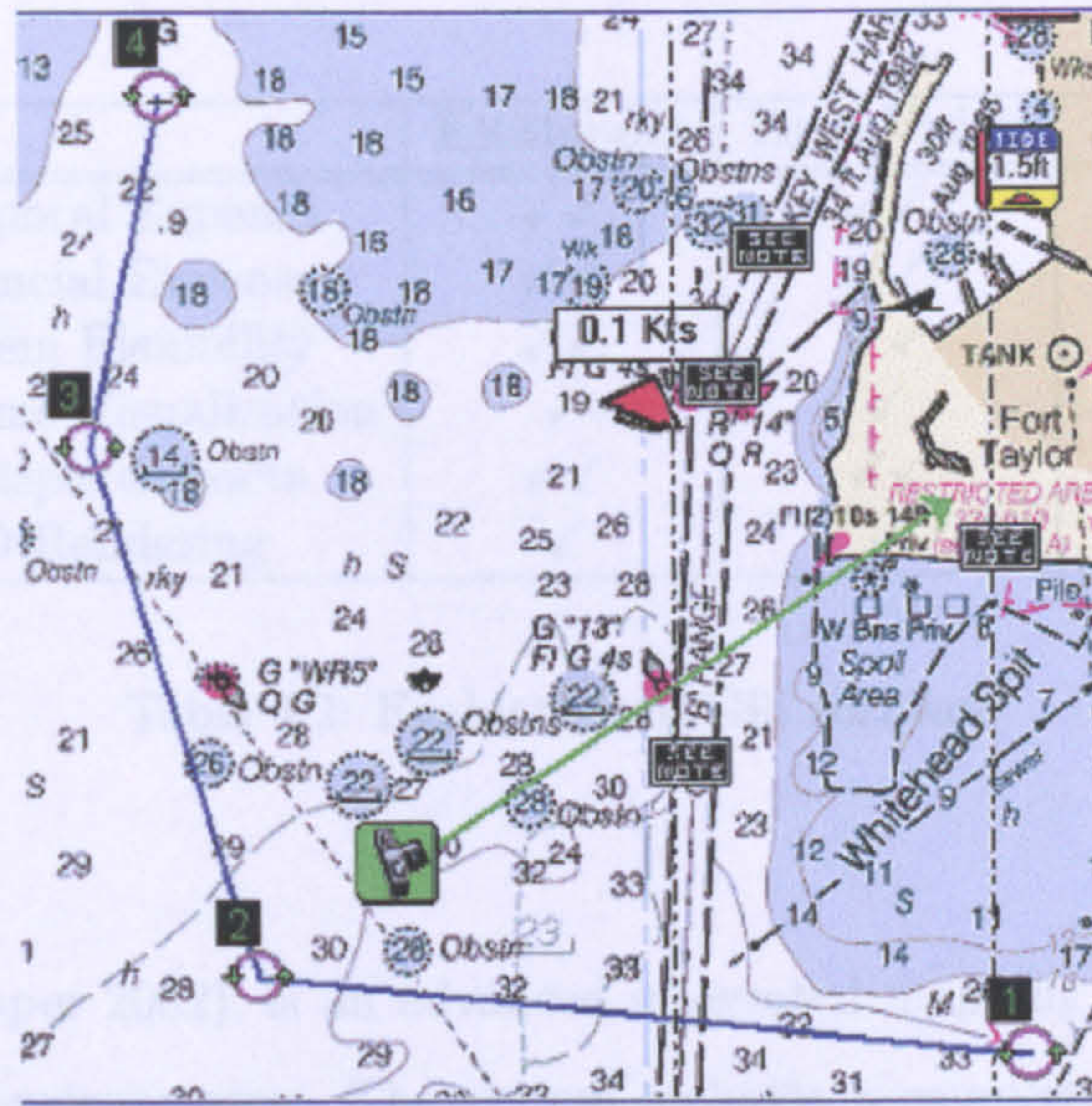

Figure 4.4: Example real-time GIS marine navigation system ©2002 Maptech

ArcView GIS

ArcView software (ESRI 2002) is a powerful geographic information system developed by the Environmental Systems Research Institute. ArcView provides a relatively easy to learn desktop mapping and GIS tool that enables users to collate combinations of data and visualize information.

ArcView is the most popular desktop mapping GIS software with around 500,000 copies in use today (ESRI 2002). The system provides an easy to use interface, integration of charts, maps, tables and graphics, dynamic data updating and strong analysis capabilities. The main advantage of ArcView is that it permits the creation of intelligent and dynamic maps using data from many sources and across all popular computing platforms. Considering the visualization architectures defined in Chapter 3, ArcView would be considered a turnkey system.

EarthVision GIS

Dynamic Graphics EarthVision (EarthVision 2002) provides a geologically oriented process flow that simplifies model-building procedures of complex structures. EarthVision integrates interactive 3-D well path positioning tools with geologic models to provide the precise well planning and analysis procedures available.

4.2 Review of Contemporary Marine Visualization Techniques

	ERMapper	EarthVision	ArcView
Temporal Expense	✓✓	✓✓	✓✓
Financial Expense	✓✓	✓✓	✓✓
System Flexibility	✓✓	✓✓	✓✓
Real-time Visualization	✓	✓	✓
Multiple datasets	✓✓	✓✓	✓✓
3D Rendering	✓	✓	✓

Table 4.2: Evaluation of GIS software

ER Mapper GIS

ER Mapper (ERMapper 2002), is an advanced integrated mapping system running under both Unix and PC environments. The system includes a complete library of algorithms to process a wide variety of data, from satellite data (Section 2.6.1) to sub-surface seismic data (Section 2.6.4). The algorithms have been tuned to provide a specific solution to the application requirement and can be modified or redesigned by the user. ER Mapper is a geographic image processing software product, providing little room for modification although ER Mapper does allow the author to develop and write their own image processing algorithms.

GIS Software Evaluation

Table 4.2 shows that the GIS systems can be used for handling multiple datasets simultaneously but are not well adapted to 3D renderings which is required for the bathymetric marine datasets. GIS is best suited to 2D terrain maps and land survey analysis. A marine hybrid of GIS is the turnkey systems specifically built for marine visualization. These systems, such as Fledermaus are considered in some detail in the next section.

4.2.3 Purpose Built Turnkey Marine Visualization Systems

While GIS supports 2D spatial analysis very well, they do not provide easy to use 3D visualization or volumetric analysis found in more specific marine visualization software such as Fledermaus (Nautronix 2000) and CFloor (Smedvig 2000). This section provides a brief overview of these two popular marine visualization tools and also introduces DredgePack (Coastalo 2000), a purpose built dredging visualization system.

4.2 Review of Contemporary Marine Visualization Techniques

Fledermaus

Fledermaus (Nautronix 2000) is an interactive 3D data visualization system that is used for a variety of applications including swath mapping, environmental impact assessment, mining, geology, cable laying and dredge planning. The system allows the user to explore a virtual 3D world containing many possible object models such as surfaces, volumes, density fields and cross-sections. It provides several visualization interfaces that allow the user to explore the high resolution terrain data.

Fledermaus contains a suite of over fifty programs of which there are five main applications using graphical user interfaces:

- Fledermaus - Main 3D exploration tool and visualization workhorse.
- Dmagic - Interactive data interpretation tool.
- AvgGrid - Average Gridder, an interactive creation tool.
- Shade - Surface shader.
- CmapEdit - Colour Map editor.

The rest of the programs in the Fledermaus package are command line driven.

Example Scene Generation

The specific steps required to assemble a 3D scene will depend on the object type that the user wishes to visualize. If seabed topography is to be visualized, the 3D data will be imported, converted into a Fledermaus object and then loaded into the Fledermaus visualization program.

For example:

- DMagic or AVGrid imports the 3D sonar bathymetric data.
- DMagic is then used to format and preview the surface using a colour map to texture and highlight the relief.
- DMagic creates the final 3D surface object.

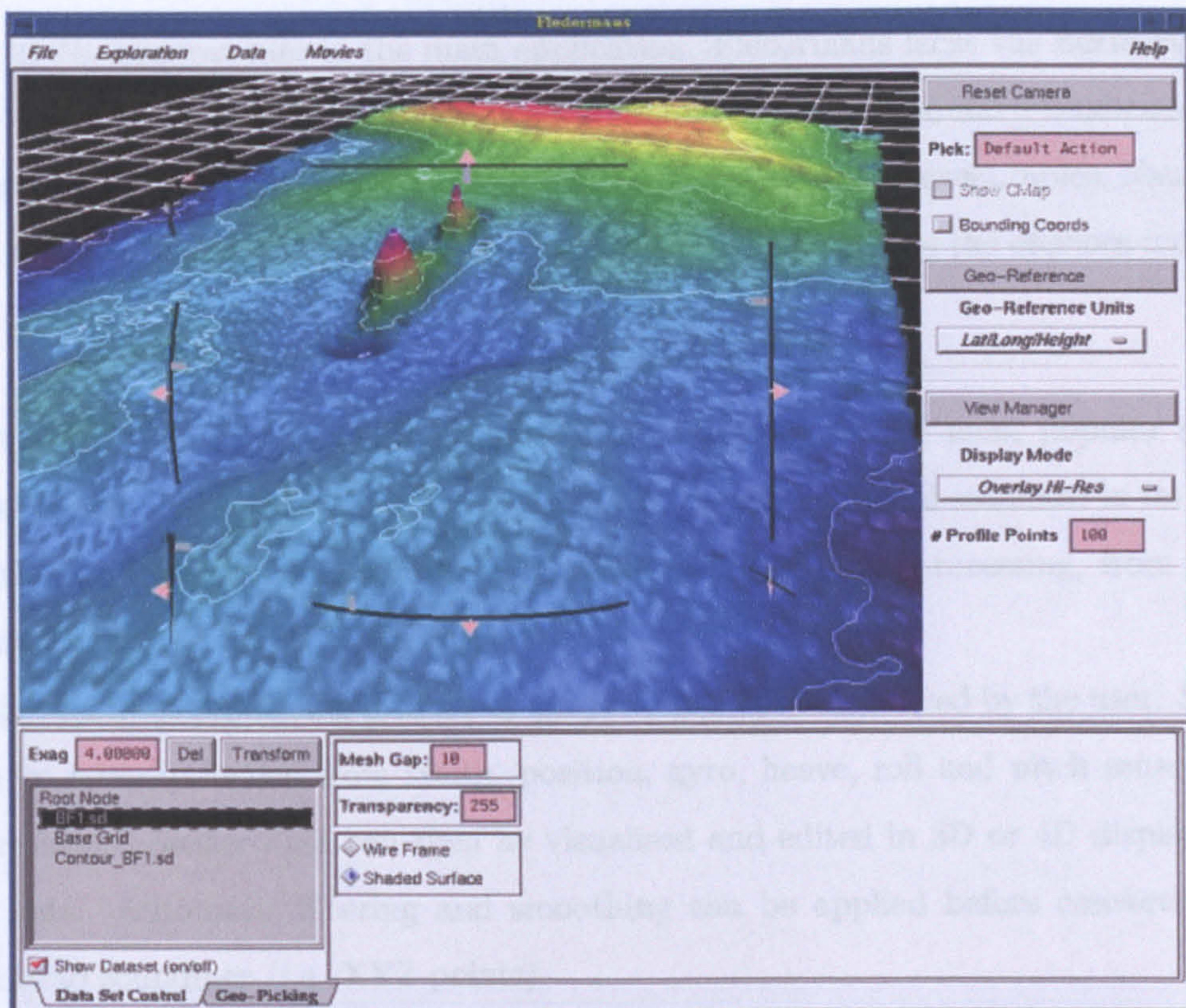

Figure 4.5: Example screen shot from Fledermaus (Nautronix 2000)

- The created object is loaded into Fledermaus to visualize and explore the bathymetry.

Steps 1-3 can be speeded up by using the specific command line applets provided with Fledermaus. This is generally the case if the data preparation steps are the same for all visualizations.

Figure 4.5 shows the final stage of visualization. The black lines making up a square within the main view are used together with the 'bat', a 3D special hand held device enabling the user to navigate through the scene.

Fledermaus is a 3D marine visualization system specialising in the visualization and interaction of 3D bathymetric data. However, although Nautronix speak openly in their literature about object orientated design and interaction, Fledermaus is still very much a turnkey visualization system. While there are fifty programs or modules that make up the Fledermaus package, most of these are late breaking functions that have not yet found their way into the main Fledermaus application. The user is still limited to the functionality

4.2 Review of Contemporary Marine Visualization Techniques

provided by the programmer in the main application. Fledermaus lacks the flexibility that would be provided by a marine visualization system adopting a modular visualization environment architecture. By gluing so much functionality into single executables, Nautronix loses the flexibility required for diverse applications that characterise the offshore industry.

CFloor

Roxar's CFloor (Smedvig 2000) is probably the industry's second most popular seabed visualization mapping software and is recognised as the international standard in its sector along with Fledermaus. CFloor provides a range of bathymetric processing, from sensor data management to making of the final plots.

CFloor organises processing project-by-project, as loaded and saved by the user. Survey data can be initially loaded from swath, position, gyro, heave, roll and pitch sensors and tide information. Sensor data can then be visualised and edited in 3D or 4D displays and constant sets. Automatic filtering and smoothing can be applied before converting the sensor data to soundings (i.e. XYZ points).

Terrain modelling

CFloor provides a variety of methods for digital terrain modelling with all parameters involved being user-defined. The modelling is based on chart definitions, soundings, boundaries, holes, coast lines, fixed points and algorithm settings. Filtering and smoothing methods can also be included.

The system operates using regular grids, irregular grids and triangular irregular networks (TIN). Powerful tools can be used for cutting and merging of terrain models. Grids representing statistics of each cell in a grid can also be calculated. These include minimum or maximum values, difference values, mean values, standard deviations and other statistical values.

The resulting terrain models can be merged with seabed classification grids. Also points classified as shoal, deep, ridge, valley or saddle points can be derived from a terrain model.

Volumetrics and Profiles

Profiles are vital for cable laying and pipeline planning (Section 2.3). CFloor provides support for profiles including intersect lines, cross-sections and fence diagrams (Smedvig

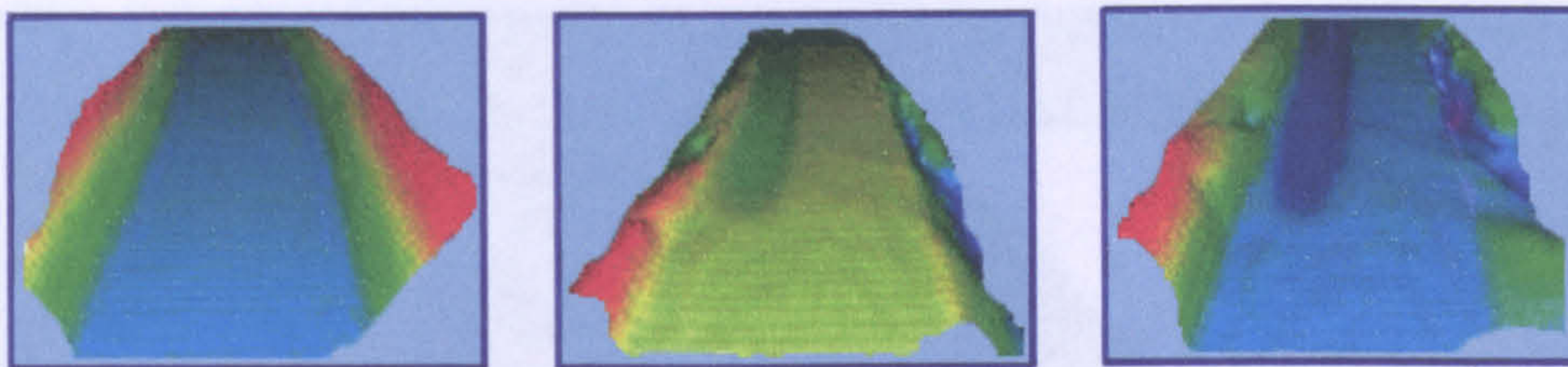

Figure 4.6: CFloor bathymetric images (Smegvig 2000)

2000). The trace of the profile can be imported into the system from files or digitised on-screen by the user. Profiles are viewed in either 2D or 3D, and the result included in plots. CFloor also provides the user with volume calculations such as volume for dredging (cut and fill), volume between terrain and other figures.

CFloor contains several functions that are dedicated to 2D, 2.5D and 3D plots, cartographic operations, as well as text, drawing and page layout. The system contains hydrographic symbols, and tools are included for users to add their own symbols.

CFloor is another turnkey system providing a slightly different focus than Fledermaus (Section 4.2.3). CFloor's strengths are in its strong charting functions providing professional charts and graphics.

DredgePack

One important and complex offshore task is the process of dredging (relocating silt and sand from the seabed (OPL 1998)). This section examines some real-time marine visualization software called DredgePack (Coastalo 2000). DredgePack is a turnkey real-time dredging visualization system providing real time digging information for cutter suction, hopper and excavator operators.

The survey information is initially mapped into a colour-coded matrix file allowing users to control the colours and highlight the material they wish to remove. Figure 4.7 shows a screen shot from DredgePack showing the sea floor. The red material has not been dredged properly and therefore is higher than its surrounding seabed. The operator therefore knows exactly where to dig as the digging device will be correctly positioned and rendered on the display in real-time.

DredgePack imports ASCII XYZ files to fill a colour coded depth matrix. Each matrix

4.2 Review of Contemporary Marine Visualization Techniques

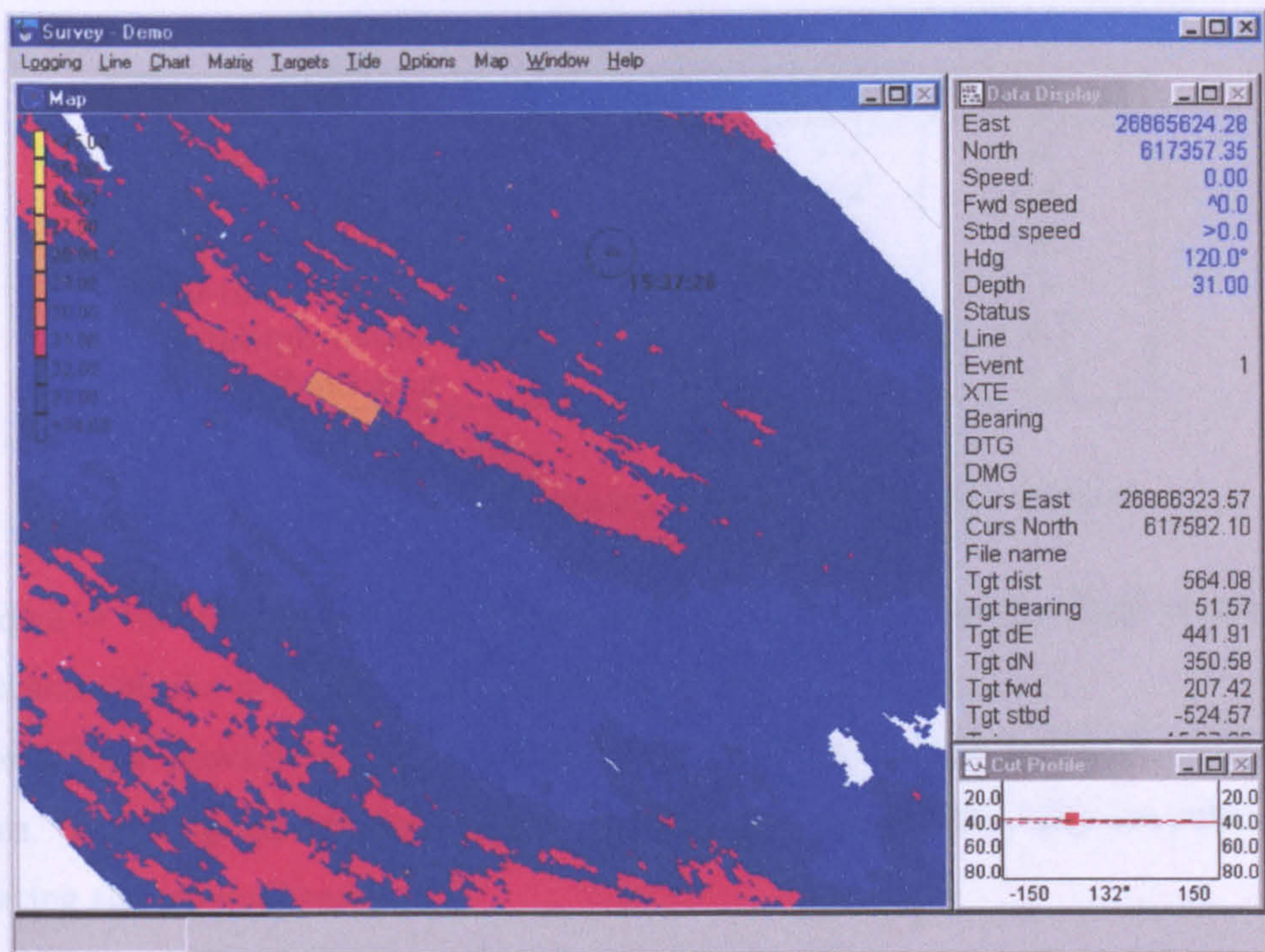

Figure 4.7: Sample screen shot from DredgePack (Coastalo 2000)

can contain millions of colour coded depth cells. DredgePack remaps each cell based on the calculated position and depth of the digging tool. The location of the digging tool is calculated with a combination of navigation, rotational and tilt sensors.

This colour-coded depth display is remapped as the cutting tool passes through each cell at a depth lower than the depth value. This allows the operator to increase their digging efficiency by working in precise areas where material is available.

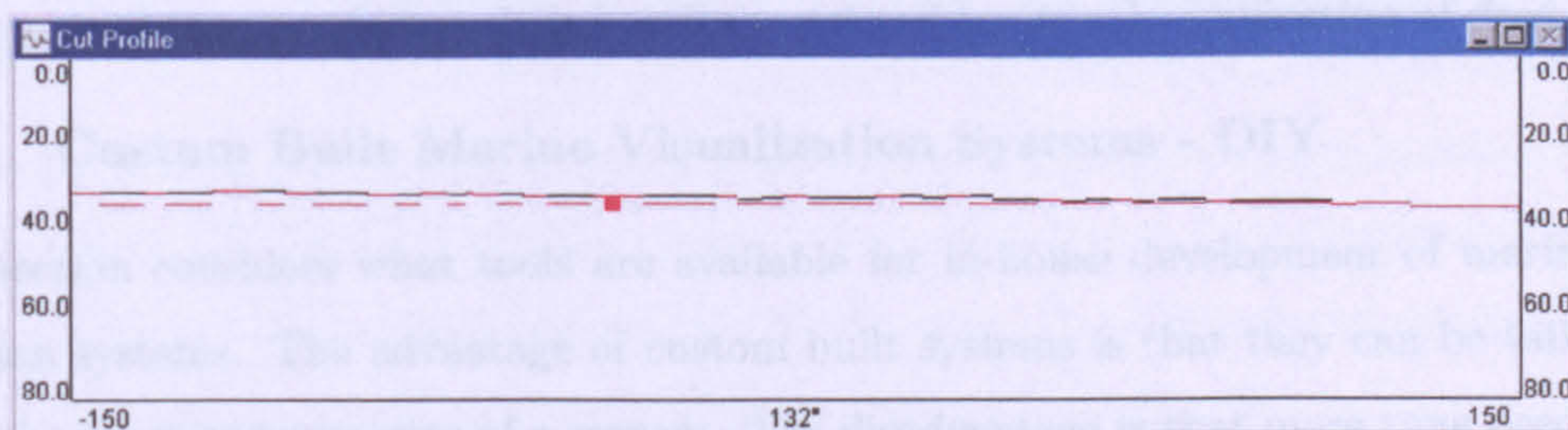

Figure 4.8: DredgePack profile window (Coastalo 2000)

The profile window in Figure 4.8 shows the exact depth of the cutter head, along with the 'as surveyed' vs. 'as cut' profile. For a cutter suction dredge, this is a profile along

4.2 Review of Contemporary Marine Visualization Techniques

	DredgePack	CFloor	Fledermaus
Temporal Expense	✓	✓✓	✓✓
Financial Expense	✓	✓✓	✓✓
System Flexibility	✓	✓✓	✓✓
Real-time Visualization	✓✓✓	✓✓	✓✓
Multiple datasets	×	✓✓	✓✓✓
3D Rendering	×	✓✓✓	✓✓✓

Table 4.3: Evaluation of turnkey marine visualization systems

the radius of the digging tool. For hopper dredges, this can be longitudinal or transverse profiles through the drag arm heads (Coastalo 2000).

DredgePack provides a limited yet effective turnkey system to facilitate dredging operations. The 2D graphical displays and interface are primitive but they are sufficient for completing the required tasks.

Purpose Built Marine Visualization Software Evaluation

Table 4.3 shows that Fledermaus is a powerful tool for marine visualization. Fledermaus is probably the most popular marine visualization systems in use today but its success has always been its post-survey visualizations of bathymetric data and it is not recognised for its real-time marine visualizations. Another problem with Fledermaus is its turnkey approach to marine visualization which reduces its flexibility.

DredgePack was included in this study because it is a good example of how a completely different software system is required for a different offshore activity. Although this software has good real-time rendering. It is heavily restricted by its sole application of dredging⁴.

4.2.4 Custom Built Marine Visualization Systems - DIY

This section considers what tools are available for in-house development of marine visualization systems. The advantage of custom built systems is that they can be tailored to meet the exact requirements of a system. The disadvantage is that more time needs to be invested in the initial design and building of the system.

⁴Of course this is the niche area targeted by the company. The restriction referred to is in relation to an ideal system's ability to be applied generically across all offshore activities.

4.2 Review of Contemporary Marine Visualization Techniques

The example systems below all use Microsoft's Visual C++ (White, Scribner & Olafsen 1999). VC++ is a powerful and complex development tool for building 32bit applications for Windows 95/98/2000/NT and XP operating systems. The class library included with Visual C++, (the Microsoft Foundation Classes), has become the industry standard for Windows software in a variety of C++ compilers.

Visual C++ with OpenGL

OpenGL (Woo, Neider & Davis 1997), is a software interface for graphics hardware that allows graphics programmers to produce high-quality colour images of 3D objects. The functions available in the OpenGL library enables programmers to build geometric models, view models interactively in 3D space, control colour and lighting, manipulate pixels, and perform such tasks as alpha blending, anti-aliasing, creating atmospheric effects and texture mapping.

Visual C++ with the Visualization Toolkit (VTK)

The Visualization Toolkit (Schroeder 1998) is a relatively new object orientated approach to 3D graphics and scientific visualization. It contains a number of routines and functions commonly used in visualization allowing the programmer to effectively build their own visualization systems. VTK is relatively new in comparison with the OpenGL graphics libraries. However, VTK is becoming ever more popular especially in academic circles and does offer a number of features missing in OpenGL.

Visual C++ with RealiMation SDK

DataPath's RealiMation (DataPath 2001), is a powerful 3D graphics and visualization programming library. The system is renderer independent (the architecture is not built upon any one particular display technology such as OpenGL). It has been designed so that different 3D display mechanisms can be used at run-time. Applications can consequently be written for multiple platforms without changing the underlying code.

Visual C++ / Device contexts

The final programming option is to use Visual C++ with the inbuilt graphics tools such as the Windows device context. Unfortunately, the programmer would have to write all

4.2 Review of Contemporary Marine Visualization Techniques

	C++/RealMation	C++/VTK	C++/OpenGL	C++
Temporal Expense	✓✓	✓✓	✓✓	✓✓✓
Financial Expense	✓✓✓	✓	✓	✓
System Flexibility	✓✓✓	✓✓✓	✓✓✓	✓✓✓
Real-time Visualization	✓✓✓	✓✓✓	✓✓✓	✓✓✓
Multiple datasets	✓✓✓	✓✓✓	✓✓✓	✓✓✓
3D Rendering	✓✓✓	✓✓✓	✓✓✓	✓✓

Table 4.4: Evaluation of DIY systems

their own graphics routines such as matrix and vector manipulation functions. The main disadvantage of this technique is that a large amount of time is invested 'reinventing the wheel' (time better spent focusing on the actual problem). There is no real hardware support for these graphics tools and the programmer would be at a distinct disadvantage if they did not use a time and tested graphics SDK such as OpenGL or DirectX.

Custom Built Marine Visualization Systems DIY - Software Evaluation

The main advantages of the DIY approach (shown in Table 4.4) is that the system can be tailor made to fit any requirements and can therefore be used to build a marine visualization system that incorporates all the desirable characteristics defined previously.

The main disadvantages of the DIY approach is the time required to develop the marine visualization system. The pure C++ option with no graphics library support (such as OpenGL) is the most expensive of the four options from a time development perspective (as the graphics SDK will need to be developed in house). The pure C++ option also suffers because it will not be able to take advantage of hardware acceleration such as the acceleration provided on OpenGL graphics cards. This acceleration will be essential for rendering complex large geometrical datasets.

The financial expense (excluding staff development costs) for all DIY approaches would need to include a good programming development environment such as Microsoft's Visual Studio (White et al. 1999). The RealMation approach is more expensive as it requires both Visual C++ and the RealMation graphics SDK.

4.3 Evaluation of Contemporary Marine Visualization Systems

Considering the contemporary marine visualization tools described above, it is the author's opinion that Fledermaus (Nautronix 2000) currently provides the best marine visualization tools to the offshore engineer. However, tools such as Fledermaus rely on Silicon Graphics technology that is not feasible in an offshore environment⁵. Major advancements in PC graphics processing technology have been achieved in recent years yet the marine industry has not taken advantage of these processor developments. This is discussed in more detail in the next chapter.

Research has found that current real-time marine visualization is limited to 2D representations of vessels on digitized charts (Figure 4.4) and is predominantly used for navigational purposes. Other real-time displays include 2D plan representations of submerged equipment that provide visual feedback to the operator regarding the machine's underwater state. For example, a 2D graphical representation of an ROV manipulator arm.

This study has revealed that 3D marine visualization systems available today are generally post-survey (office based) visualization tools (eg. Fledermaus) built predominantly for the interpretation of bathymetric data. There has been very little research into the use of 3D computer graphics for real-time visualization of offshore survey activities. Major advancements in PC graphics processing technology has been achieved in recent years yet the marine industry has not taken advantage of these processor developments. The author could not find any reference to work where a marine visualization system could read and encapsulate all these disparate data into a single display. An offshore operative currently requires numerous visualization systems for the interpretation of data from a single survey.

There does not currently exist a single marine system that visualizes a specific offshore process in its entirety. The focus of attention has always centered on the main focus data (such as terrain datasets). The author has been unable to identify any research that has investigated the possible benefits of visualizing the actual offshore process and related information that are indirectly yet inextricably linked to the focus data. For example, a

⁵PCs are preferred to Silicon Graphics as they are generally more robust, cheaper and easier to repair (the parts are easier to obtain in foreign countries).

4.4 Proposed Marine Visualization System

traditional diamond mining survey and visualization would generally focus on seabed bathymetry. The benefits of a real-time display that include the diamond mining tool correctly positioned and orientated on an accurate seabed, the tool's Mother ship and real-time updates to the constantly dredged seabed have yet to be investigated.

4.4 Proposed Marine Visualization System

This section proposes seven high level requirements for a new marine visualization system based on the initial four desirable characteristics for a marine visualization system and on the limitations of contemporary visualization systems. These are:

- Post-survey 3D visualization of bathymetric data.
- Mapping computer generated objects onto sonar data.
- Geometrical reduction of models for rendering efficiency
- Encapsulation of multiple datasets relating to a single survey
- Proof of concept of real-time 3D marine visualization
- Visualization of complex offshore environments with multiple real-time data streams.
- Real-time high resolution sonar per-ping visualization in 3D.

Due to the diverse nature of activities faced by the offshore industry (Chapter 2), the proposed marine visualization system should be constructed using a modular architecture (Chapter 3) in order to provide a generic visualization tool for all offshore activities.

These seven elements are now described in more detail:

4.4.1 Post-survey 3D Visualization of Bathymetric Sonar Data

Previous chapters have shown that one of the most important offshore activities in the industry is the gathering and interpretation of data relating to underwater terrain topography. Sonar is the primary data acquisition method for gathering information relating to the seabed and therefore any marine visualization system must be able to import and

4.4 Proposed Marine Visualization System

interpret sonar data collected from an offshore survey. The initial requirement for the marine visualization system is therefore the post-survey interpretation and visualization of 3D bathymetric data collected using a continuous sweep multi-frequency sonar array. 3D visualization of this data has been selected to naturally replicate the survey area with a computer model of the survey area. Consequently the viewer will require no training time in learning to interpret the visualization. Abstractions of the visualization will be permitted to incorporate other data sources such as coloured terrain to indicate water depth. The gathered data for visualization may be 2D scalar and 3D point.

4.4.2 Mapping Computer Generated Objects onto Sonar Data

The 3D visualizations provided to the user should not be limited to 3D terrain generated from the sonar data. To improve the realism and accuracy, computer generated objects should be imported into the 3D world to facilitate the user's comprehension of the data. For example, if the dimensions and position of a submerged concrete pipeline are known, an accurate computer generated model of the pipe should be present within the underwater model.

4.4.3 Geometrical Reduction of Models for Rendering Efficiency

Section 2.6.4 described how sonar technology has improved in recent years and now provides offshore engineers with extremely accurate high resolution data. This high resolution data when filtered and mapped into 3D geometry will result in a corresponding high resolution terrain dataset containing thousands of polygons. Consequently, a marine visualization system should have the facility to reduce the complexity of rendered scenes therefore increasing display rates and providing real-time viewing for the user. It is important that the high resolution of the datasets should not be compromised and the user should always be able to view areas of interest at the highest possible resolution with less important geographical areas rendered at a lower resolution.

4.4.4 Encapsulation of Multiple Datasets Relating to a Single Survey

The importance of this requirement has already been stated earlier in this chapter. This requirement is a result of contemporary visualization systems inability to integrate multiple

4.4 Proposed Marine Visualization System

datasets from a single survey into a single visualization system. For example combining ROV video footage, bathymetric, side scan and sub-bottom-profile data to provide the viewer with a single visualization related to a pipeline survey.

The proposed system should therefore provide the viewer with seamless integration of multiple and disparate data into a single and succinct user interface that provides a unified database of information.

4.4.5 Proof of Concept of Real-time 3D Marine Visualization

Chapter 2 identified a number of complex offshore activities that typify the offshore industry. This chapter has shown that real-time marine visualization tools are often limited to 2D navigational systems. As the complexity of offshore activities increase, the potential for real-time 3D displays of these activities is unknown. Our proposed marine visualization system should investigate the possibility of providing the user with a real-time 3D visualization of offshore activities. This proof of concept visualization should initially be developed for a simple offshore activity.

4.4.6 Visualization of Complex Offshore Environments with Multiple Real-time Data Streams

If the proof of concept real-time visualizations described in the previous section are successful, then the natural progression for a real-time 3D marine visualization system would be to increase the complexity of the offshore activity and therefore the complexity of the marine visualization tool. Research would focus on whether it would be possible to augment the real-time marine visualization system from real-time displays of simple offshore activities to complex offshore activities. More importantly, would such a system facilitate or hinder operations and activities offshore⁶?

4.4.7 Real-time High Resolution Sonar per-ping Visualization in 3D

Requirements for definitions of real-time will vary from one offshore activity to another. In the proposed marine visualization system for example, up-to-date images of 3D seabed

⁶Complex offshore activities that can be visualized in real-time does not guarantee that the viewer will have improved insight into the offshore operations. It is feasible that these visualizations could cause unforeseen problems and reduce productivity or increase error rates (potentially disastrous in the offshore industry).

4.4 Proposed Marine Visualization System

bathymetry may only be required every ten minutes. In this instance, entire sections of seabed may be imported from terrain maps stored on disk. However, for certain activities, real-time has a very different requirement. For example, offshore activities such as deep water diamond-mining involve a continuously changing seabed and the offshore operative needs to be aware of the topology of the changing seabed on a second-by-second basis. If the previous two requirements have been successfully met (outlined in the previous two sections) then this new requirement will consider the possibility of real-time per ping sonar updates to 3D terrain datasets (modifying polygonal terrain datasets by directly correlating individual sonar pings to vertices in the displayed dataset).

The previous section has outlined and described seven requirements for a novel marine visualization system. This proposed marine visualization system is hereby referred to as the Whole Field Modelling System or WFM. The name reflects one of the principle objectives which is to model entire fields of offshore activities and operations within a natural 3D viewing environment.

Chapter 5 describes the software and hardware architectures that will be used for the development of WFM based on the above requirements.

Chapter 5

WFM System Architecture

This chapter defines the software and hardware used for WFM's implementation and describes a basic dataflow architecture for a simple visualization of seabed terrain data gathered from an offshore marine survey. The chapter concludes by introducing five field case studies that each contribute to the development and testing of the WFM marine visualization system proposed in the previous chapter (Section 4.4). These case studies are each covered in detail in subsequent chapters.

5.1 WFM Hardware Implementation

From the outset it was decided that WFM would run on a standard desktop PC with graphics acceleration. PCs are more ubiquitous offshore than state of the art Silicon Graphics machines, significantly cheaper, can be repaired quickly and easily and provide competitive rendering rates using today's graphics cards (Section 5.1.1).

The initial WFM system consisted of the following hardware:

- Dell Pentium III P550 MHz processor.
- 256 MB RAM.
- 25GB capacity hard drive.
- Creative GII nVidia graphics accelerator.
- 17" Monitor.
- 100BaseT network card.

5.2 WFM Software Development

5.1.1 Graphics Processor Technology

It is important to note that realistic terrain images in the entertainment industry rely on low resolution datasets texture mapped with high resolution images. Consequently, the computer is able to translate, rotate and manipulate the environment extremely quickly due to the low level of geometry that needs to be transformed. The WFM visualization system cannot rely on elaborate texture mapping to 'pretend' high resolution displays. For an effective marine visualization system, the converse of the games methodology is true; WFM requires extremely accurate seabed geometry that can only be achieved using high resolution polygon data sets. A high-end graphics hardware accelerator is therefore essential if reasonable frame rates are to be achieved¹.

WFM's success must be partly credited to the recent development of the nVidia graphics processor (Dang 2001) (nVidia 2002) released by nVidia in the late 1990s. This new graphics card housed an innovative new graphics pipeline architecture that provided a 100% increase in performance when compared to its nearest rivals such as the Voodoo 3500² (Voodoo 2002). Consequently, nVidia provided the graphics horsepower required for high resolution seabed terrain rendering on a desktop PC.

5.2 WFM Software Development

After careful consideration, it was decided that Microsoft's Visual C++ Version 6.0 (White et al. 1999) would be used for the main system development. Visual C++ is probably the most professionally used language in the computing industry and also the author's preferred programming language. The graphics programming would be implemented using DataPath's RealiMation SDK (DataPath 2001) (Section 4.2.4). RealiMation was selected for three reasons:

1. RealiMation is hardware and renderer independent. Consequently, WFM will always have access to the latest developments in the graphics industry. For example, Interchanging between OpenGL and DirectX would not present any overhead such as

¹'Reasonable' frame rates in this thesis are defined as greater than 15fps - Although ideally, research points to frame rates of between 20 and 60fps (SMPTE 1993).

²In Jan 2000, an nVidia II would typically render at fifteen million polygons per second - The Voodoo 3500 would peak at nine million polygons per second.

5.3 WFM Visualization Pipeline

source code modifications and recompilations.

2. RealiMation's SDK contains an extensive programming library such as vector math and matrix manipulation routines. This results in the graphics programmer retaining the low-level control that would be required for the development of a complex graphics system.
3. The RealiMation SDK is a new and popular graphics programming environment adopted by a number of respectable companies such as The Defence Engineering and Research Agency (DERA). Subsequently, RealiMation will have a strong and secure customer base that would be important for system continuity.

If after development, RealiMation was no longer available³ (for example the company became bankrupt), then it should be noted that a marine visualization system based on RealiMation would still work (just because a system is no longer available does not mean that all systems built on that architecture will immediately stop working) although problems may occur later due to the difficulty in keeping the system up-to-date with new graphics languages and updates. Most importantly, the concepts applied within this thesis could be implemented in any graphics language (OpenGL, DirectX etc).

5.3 WFM Visualization Pipeline

Chapter 3 described how a modular approach to visualization problems has resulted in the development of powerful MVE visualization tools that can be tailored to meet specific visualization requirements. In the previous chapter, one of the desirable characteristics of an ideal marine visualization system was system flexibility and it was suggested that a MVE approach (which is lacking in contemporary marine visualization systems) would provide the offshore engineer with the ability to tailor visualizations to meet the wide variety of offshore tasks that were highlighted in Chapter 2.

This section defines a marine visualization pipeline for WFM by extending the Haber-McNabb visualization model described in Chapter 3 (shown again in Figure 5.1 for convenience).

³Although this argument could be directed at any hardware or software company.

5.3 WFM Visualization Pipeline

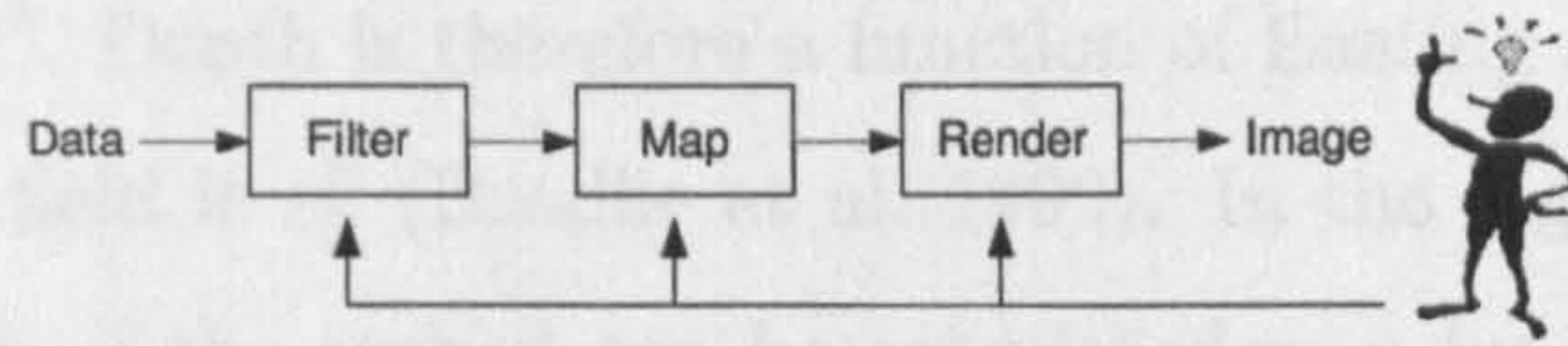

Figure 5.1: Extended Haber-McNabb reference model

In order to incorporate such a modular approach to WFM's implementation, a dynamic runtime object framework (based on a publication by Smetak & Caputo (1997) and substantially improved by Rafe Montgomery of SRD) was used as the foundation building blocks for WFM. This dynamic runtime object environment permitted individual objects to be built and compiled as dynamic link libraries that could then be linked together at runtime providing variable architectures (such as the MVE architecture described previously in Chapter 3). As WFM slowly developed over time (visible in subsequent case study chapters), new filter, map and render modules were created increasing the flexibility of the WFM marine visualization system.

Figure 5.2 shows the WFM visualization pipeline describing the dataflow required to visualize seabed terrain from a sonar survey. The arrows show dataflows from one module to the next. The top right hand corner of each module describes the type of visualization process: *F* for filter, *M* for map and *R* for render. The filter, map and render processes were introduced to the reader in Section 3.1.1.

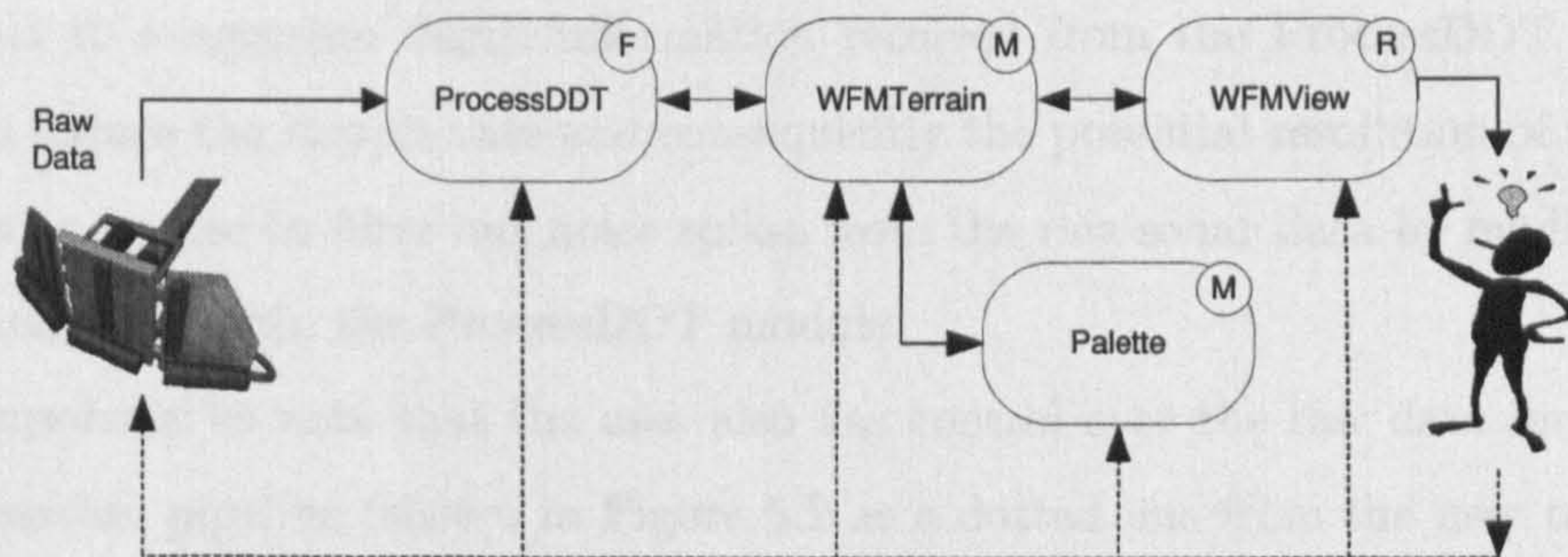

Figure 5.2: WFM Pipeline for a basic survey

Each of these modules is a separate DLL file that is executed at runtime. ProcessDDT is the filter stage of the visualization pipeline. The module takes the raw sonar data (Section 2.6.4) and filters it into a gridded data structure of height elevation fields called digital

5.3 WFM Visualization Pipeline

terrain maps or DTMs⁴. Depth is therefore a function of Easting and Northing. A popular notation for this data field is ε_2^S (Brodie et al. 1992). In the digital terrain example, the dependent scalar depth of the seabed can be calculated as a function of two independent variables: Easting and Northing.

These DTMs are grouped into a hierarchy of files (called a DDT⁵) that provide the input to the WFMTerrain mapping module. The WFMTerrain module is concerned with converting the regular height elevation grids from the DDT into 3D geometry and storing the created vertices and faces in a 3D database⁶. A second mapping module, Palette, provides the user with the facility to texture the seabed using various colours that relate to seabed depth (hypsothetic hints). The WFMTerrain module queries the Palette module with a depth and receives a corresponding RGB colour. The final process in the visualization pipeline is the render process, WFMView displays the geometry created from the WFMTerrain module presenting the user with a visualization of the seabed.

The user can interact with the visualization pipeline at any stage (a requirement of MVE implementations required in the WFM specification) . This facility is shown in Figure 5.2 by control feedback loops (dashed lines) from the user to all the pipeline processes. For example, the user may change parameters within WFMView to change the rendering style to wire-frame or zoom out to view the entire survey area. The user may change the Palette module to scroll the depths or increase the palette range. The WFMTerrain object may be modified to exaggerate depth information received from the ProcessDDT object, or, perhaps to reduce the sample rate and consequently the potential resolution of the terrain. The user may choose to filter out noise spikes from the raw sonar data by modifying noise gates parameters within the ProcessDDT module.

It is important to note that the user also has control over the raw data imported into the visualization pipeline (shown in Figure 5.2 as a dotted line from the user to the sonar transducers). For example, if the user increases the frequency of the sonar transducers, the sonar footprint will be reduced yet the potential resolution of the raw data returned will increase. Consequently this change will propagate through the visualization pipeline

⁴Details relating to the DTM file structure can be found in Appendix A

⁵Details relating to the DDT file structure can be found in Appendix A

⁶The 3D database contains all the texture, vertex, polygon and object information used in rendering. This 'RealiBase' (RealiMation's 3D database) is hereby referred to as the 'RBS'.

5.3 WFM Visualization Pipeline

resulting in a higher resolution seabed terrain map (but smaller footprint) being presented to the user.

Figure 5.3 shows a snapshot of some seabed terrain rendered using the WFM visualization pipeline described in Figure 5.2. Note the steep walls of the underwater cliff clearly evident from the hypsometric hints. This seabed data was gathered from the clear up operation of a former US Naval Base in Scotland. This debris clearance operation is discussed in detail as a case study in Chapter 9.

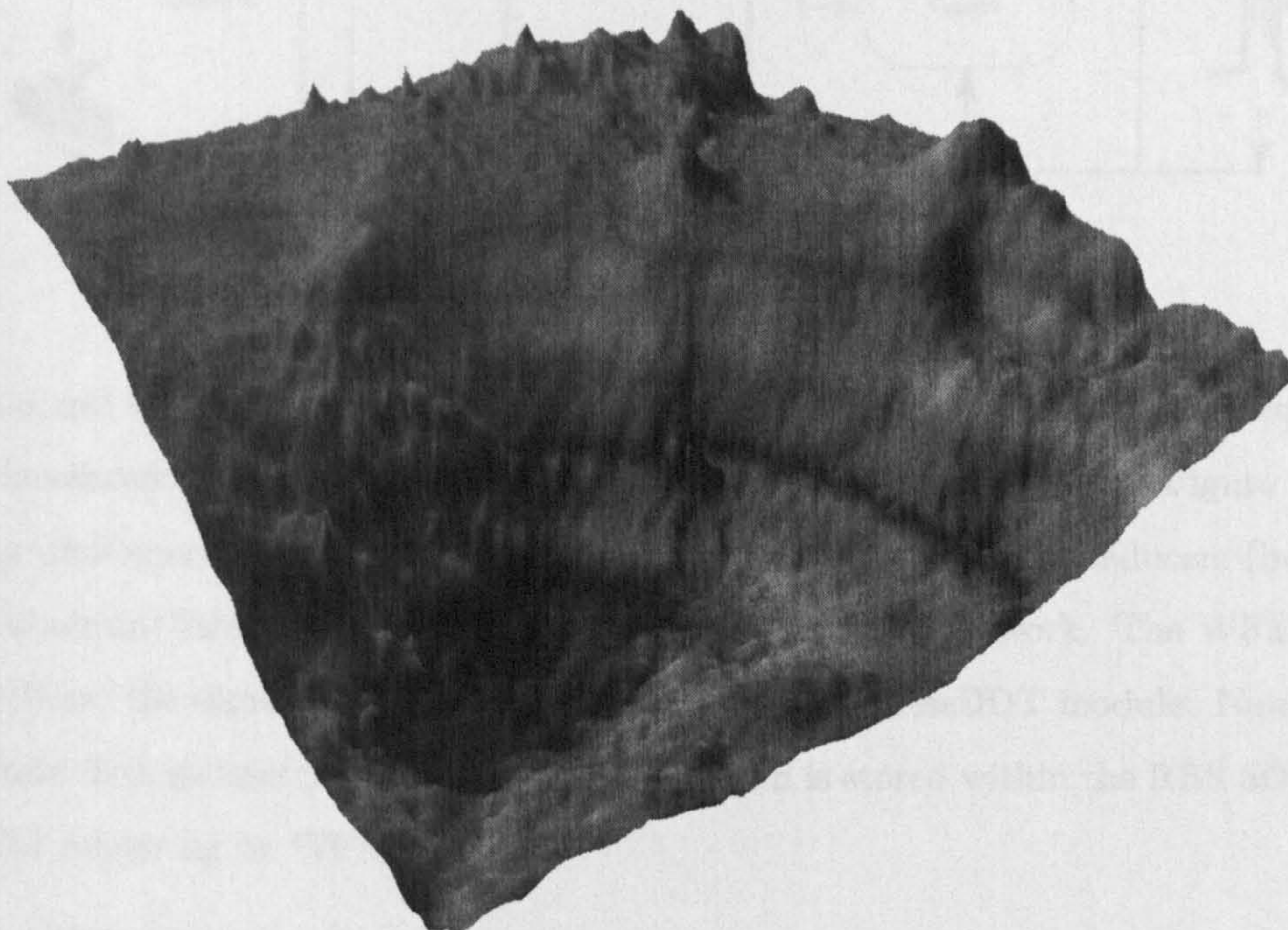

Figure 5.3: Example digital terrain map rendered using WFM - 200m²

5.3.1 Extending the Model

For an accurate representation of seabed visualization using WFM, the architecture described in Figure 5.2 needs to be extended to incorporate three more elements: the raw data input provided by the BlueBox (Section 2.6.4) via a network, a 3D database (the RBS) to store all the geometry and a central core object for initialising the 3D graphics engine. The updated architecture incorporating these elements can be seen in Figure 5.4.

Double headed arrows represent continuous flows of data. For example, WFMView is continuously accessing the contents of the RBS for rendering (not necessarily important in

5.3 WFM Visualization Pipeline

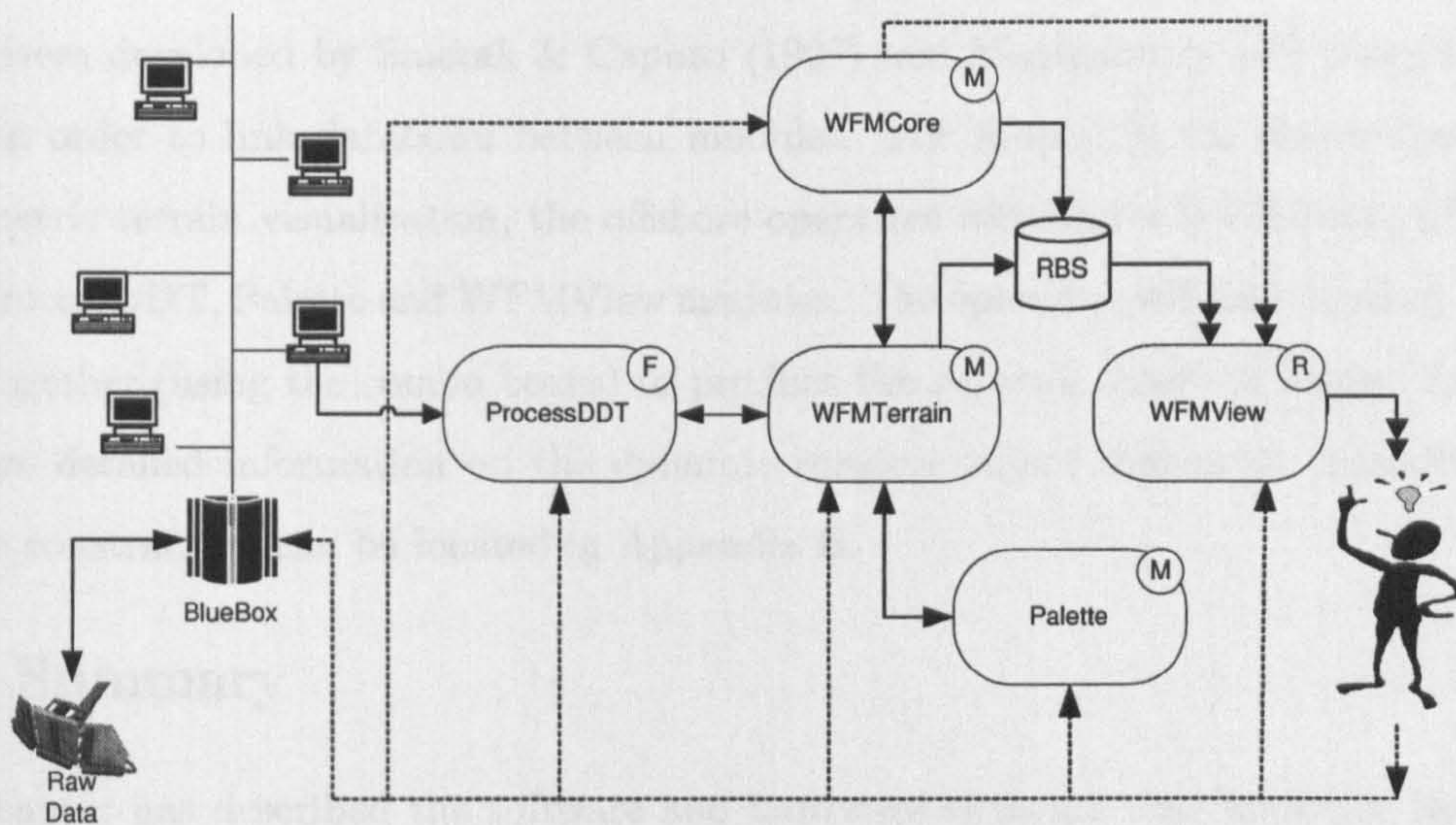

Figure 5.4: Extended WFM Architecture

this minimal static model of seabed visualization, but essential when implementing real-time visualization architectures that will be discussed in later chapters). Figure 5.4 shows how the analogue data (and all other survey data) flows from the transducers (bottom left of the diagram) into the BlueBox for broadcasting over the network. The WFM network node collects the digital raw data and sends it to the ProcessDDT module. Note that the 3D terrain data geometry produced by WFM Terrain is stored within the RBS 3D database ready for rendering by WFMView.

WFM MVE Module Compilation and Network Assembly

Filter, map and render modules were created by the author using Microsoft Visual C++, RealiMation SDK and the dynamic runtime object framework developed by Smetak & Caputo (1997) and Montgomery. This modular architecture provided an extendable and maintainable interface to WFM.

Each module, when compiled resulted in a .DLL file that was placed into a directory forming a module repository. The offshore operative could then select specific modules required for a task, load the modules and connect them together. Traditional MVE environments such as Iris Explorer (Foulser 1995) use 'visual programming' techniques where modules and their connecting links between other modules can be clearly seen and edited.

5.4 Summary

The system developed by Smetak & Caputo (1997) and Montgomery uses textual combo boxes in order to link dataflows between modules. For simple, in the above example of bathymetric terrain visualization, the offshore operative will load a WFMCore, WFMTerrain, ProcessDDT, Palette and WFMView modules. The operative will then need to connect them together (using the combo boxes) to produce the network shown in Figure 5.4.

More detailed information on the dynamic runtime object framework including DLL module construction can be located in Appendix B.

5.4 Summary

This chapter has described the software and hardware elements that underpin the WFM architecture. The system has been developed and executed on a high specification desktop PC with nVidia GPU technology and Microsoft's Visual C++, DataPath's RealMation graphics libraries and Microsoft's Windows 2000 operating systems. The dynamic runtime object library developed by Smetak, Caputo and Montgomery has provided an extendable and maintainable MVE architecture upon which to build WFM.

It should be noted that although the dataflow architecture described in Section 5.4 is simplistic and high level, it does introduce the concept of a modular architecture implemented using a number of marine visualization modules that can be 'bolted together' to meet the varying requirements of the offshore industry.

5.4.1 WFM Case Studies

One of the objectives of this thesis was to investigate and report on the effectiveness of 3D computer graphics for visualizing offshore activities and collected data (Section 1.1). 'Offshore activities' is quite a broad term as highlighted in the industry review (Chapter 2). These activities can range from the search and recovery of a sunken submarine to deep sea diamond-mining. Clearly it would not be sufficient to apply 3D computer graphic visualizations to a single marine activity and then to draw parallels across the entire industry. Consequently this research has focused on various offshore applications. Specifically: shipwreck, pipeline and debris cleanup operations. Two unique case studies were also considered for 3D graphics research: diamond mining and harbour wall monitoring.

These five case studies are considered in detail over the next five chapters and each study

5.4 Summary

highlights the diverse requirements demanded by the offshore industry. Initially the marine case study requirements are minimal such as visualizing a simple terrain map, and could be achieved using any off-the-shelf visualization tool (such as those described in Section 4.2). As the case studies progress, they increase in complexity and the WFM architecture is updated accordingly.

Developing and researching marine visualization systems 'offshore' has a number of distinct advantages. By placing the primary users and developers together at sea a special interaction is created whereby the people who know what is possible have a productive interaction with those who know what they require (Hatcher 1999). This creates a situation where productive compromises and ideas thrive, enabling software tools to be quickly conceived, created and evaluated. Hatcher (1999) describes a month of development at sea as being nearly as productive as an entire year on land due to the synergism of the working environment.

It is also imperative that marine visualization systems visualize the correct information, both for real-time and for post-survey activities. Failure of the user to correctly interpret data can result in catastrophic consequences, both financially and ecologically. For example, a marine visualization system may be used to help a dredging pilot position and manoeuvre a dredge-head directly over a high pressure gas pipe at 10m water depth. The visualization must provide extremely accurate visual information. An inaccurate visualization of the input data, for example displaying the dredging vessel with 1m vertical error, could result in the dredging vessel uprooting and fracturing the pipeline resulting in toxic and explosive gas bubbling to the surface around the dredging vessel. A fractured oil pipe could release thousands of gallons of crude oil into the sea in a matter of seconds. Consequently, marine visualization systems must be carefully constructed and developed to avoid ambiguous or incorrect visualizations.

Studying the users' interactions with a marine system is equally important. The data visualized may be correct but different people may interpret the data in different ways. Careful 'on the job' monitoring and research and development has proved to be essential for this work in understanding how people interact with different visualization techniques, and for identifying which techniques do, and do not work.

5.4 Summary

Due to the nature of the offshore industry's working environment, studying user interaction through numerous questionnaires and user interviews was not feasible⁷. User interaction and feedback was achieved through close yet discreet interaction with the offshore operatives. Careful monitoring of their work while they were actively involved in offshore operations provided the author with a greater insight into user interaction than would have been achieved through conventional techniques. Close interaction not only permitted non-intrusive monitoring of how different users interacted with the visualization systems but also permitted non-disruptive verbal communication to understand, for example, why a particular option or method had been selected or chosen. Due to the long periods spent on the vessels, the author also managed to build up a good working relationship with the offshore personnel which the author believes contributed to a more accurate feedback from the offshore staff as opposed to feedback concocted for management.

The case studies detailed over the next five chapters are summarised below. It should be noted that these case studies were not randomly selected offshore activities but were specifically chosen to facilitate in the incremental implementation, testing and study of the WFM marine visualization system. Each case study tests part of the WFM marine visualization system proposed in Section 4.4.

Shipwreck Visualization

Chapter 6 reports on how WFM has facilitated the visualization of survey data collected from the wreck of the SS Richard Montgomery which ran aground and sank off Sheerness Middle Sands in 1945. The data collected was not visualized in real-time. The data was collected and recorded during the survey and then brought back to the office for processing and subsequent visualization. The case study examines WFM's ability to provide post-survey visualizations of bathymetric data, geometrical reduction of models for rendering efficiency and the ability to map computer generated objects directly onto sonar data.

⁷The nature of the offshore working environment made traditional user interaction studies impossible. An offshore engineer who has been working 12-13hrs a day for the last month is not going to be productive filling out questionnaires after a long shift. Additionally, an engineer cannot be interrupted with intrusive interaction studies during their shift.

5.4 Summary

Harbour Wall Visualization

Chapter 7 describes how WFM has effectively visualized a submerged harbour wall in Ijmuiden, Holland. The objective of this project was to survey the harbour wall and manually overlay computer generated visible concrete blocks onto the corresponding sonar pings in order to create an accurate computer model of the harbour wall. The case study considers WFM's ability to provide post-survey visualizations of 3D point data and examines how multiple computer generated 3D models can be integrated and overlaid with sonar data.

Pipeline Visualization

Chapter 8 initially reviews traditional methods used for the visualization of pipeline data gathered offshore. The sonar systems required to gather the pipeline data are introduced including an explanation of the techniques and hardware required to locate a buried pipeline. The chapter describes post-survey pipeline visualization and describes the implementation of a new facility allowing the user to interface to various datasets related to the survey. The visualization is validated by correlating the 3D view with unambiguous ROV video footage. The chapter also introduces the first implementation of WFM for real-time marine visualization by considering rendering techniques for the stabilisation of an exposed section of pipeline in Zeebrugge. The case study describes the visualization of 3D pipelines based on ϵ_2^g bathymetric and SBP data, the encapsulation of multiple data types relating to a single survey into a single interface, the inclusion of virtual objects into the sonar computer generated model and the feasibility of a 'real-time' WFM marine visualization.

Real-time Debris Clear-up Visualization

Chapter 9 describes the effective real-time visualization of the clear-up operation of a former U.S. Nuclear Submarine Base, located in Holy Loch, Scotland. WFM was used to provide an accurate real-time visualization of a large number of varying parameters such as remotely operated vehicles, cranes, barges, grabs, magnets, and detailed seabed topography. The system has improved the field staffs' spatial and temporal awareness of the underwater environment and facilitated decision-making within the complex offshore working environment. The case study examines how real-time modelling of machinery can be used in a complex debris clear-up operations, the real-time modelling of underwater vehicles such

5.4 Summary

as ROVs and the psychological evaluation of offshore staff interfacing to a 3D graphical visualization of complex offshore procedures.

Diamond mining Visualization

Chapter 10 describes how WFM has facilitated operations within the offshore diamond mining industry by providing the crew of the MV Kovambo with a real-time visualization of a diamond-mining tool and its surrounding seabed. This WFM Visualization System was implemented by the author onboard the MV Kovambo off the coast of Namibia between August and September 2000. The case study explores real-time per ping updates to seabed terrain and considers how offshore staff interface to a 3D graphical visualization of the diamond mining process.

Each of the case studies chapters described above includes an area under investigation diagram which describes which key aspects that particular case study is evaluating. This graphic can be seen in Figure 5.5. If an element within the diagram is coloured blue, then it is being evaluated within the case study. A grey element means that the element has previously been evaluated and a grey element with a blue outline means that it has been evaluated in a previous case study but is being re-evaluated in the current case study. White elements within the diagram (such as those shown in Figure 5.5 means the area has yet to be evaluated. These figures therefore enable the reader to clearly see which elements are currently under investigation.

5.4 Summary



Figure 5.5: Area under investigation

Chapter 6

Shipwreck Visualization

The aim of this chapter is to assess how the WFM methodology described in the previous chapters can visualize data gathered from a small offshore shipwreck survey. The case study was chosen as a ‘gentle introduction’ to the seabed visualization process. It would be feasible to use any off the shelf visualization software for the visualization of this data (as shown with the MatLab example (Section 4.2.1)) yet the initial development and evaluation of WFM needed to be simple in case there were fundamental architectural problems.

Figure 6.1 gives a graphical depiction of the areas under investigation within this case study.

The objectives of this case study are fivefold:

1. Test the architecture and system described in the previous chapters for the visualization of ϵ_2^s sonar data.
2. To investigate how computer generated 3D models can be integrated with the rendered sonar terrain in order to improve user comprehension of a scene.
3. To explore techniques for defining ‘areas of interest’ (AOIs) and the efficient rendering of complex high resolution terrain datasets using ‘levels of detail’ (LODs).
4. To investigate how the rendered underwater environment can be used for a pre-dive plan for scuba divers by rendering the underwater environment as realistically as possible.
5. To explore the user interaction within the scene from a user’s perspective.

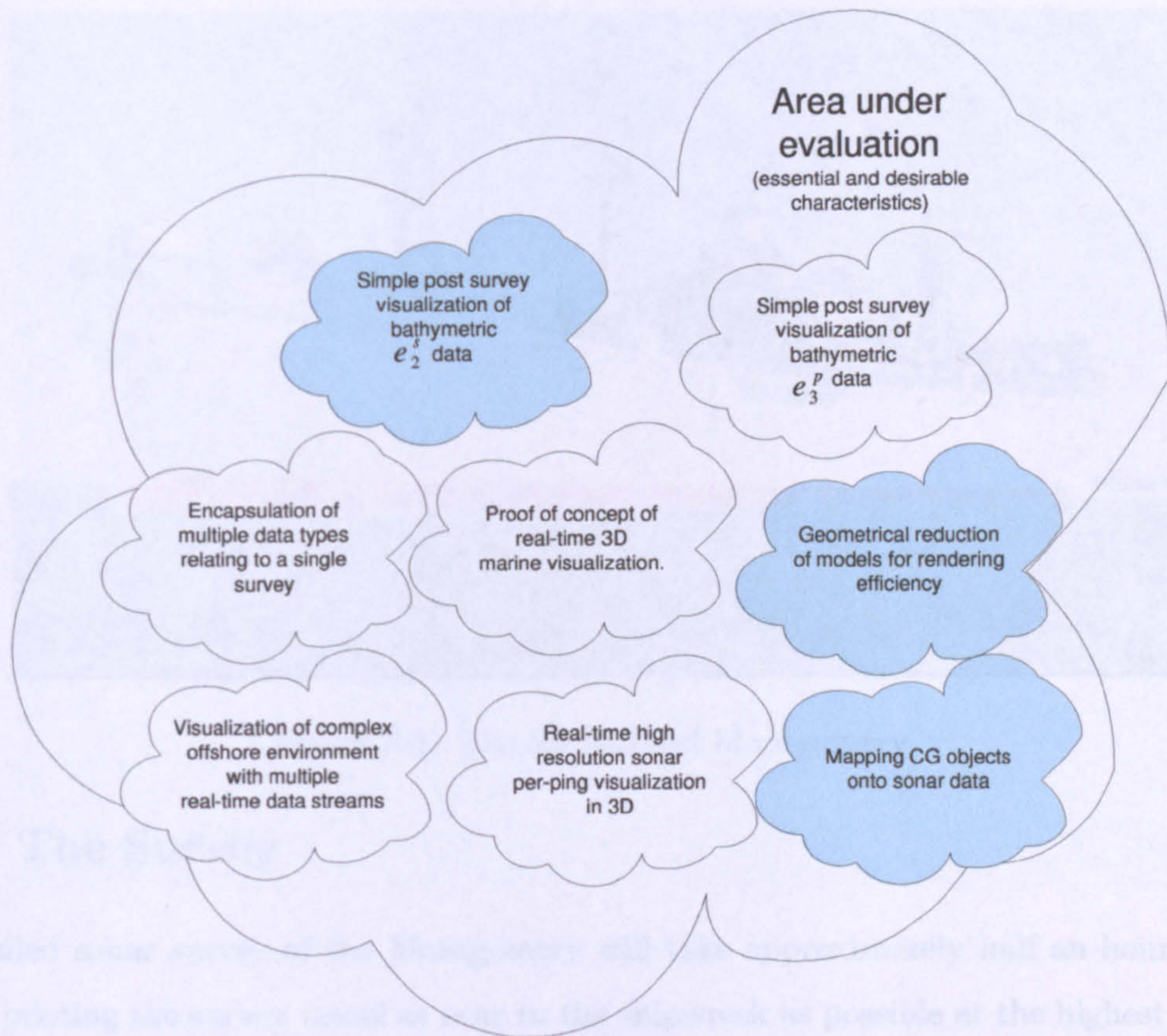

Figure 6.1: Area under investigation

6.1 Introduction

In August of 1944, the SS Richard Montgomery (Figure 6.2) sailed from America to the UK with a cargo of 7000 tons of munitions. On arrival, this liberty ship was anchored in the Thames Estuary. On the next tide, she dragged her anchor and ran aground on Sheerness Middle Sand. Intensive efforts failed to salvage the cargo completely because as the ship broke up and flooded, some holds proved inaccessible. About 1700 tons of potentially explosive material remain on board (Swale 2002). The wreck lies in approximately 15m of water and remains under continual close observation. Figure 6.3 shows a photograph of the SS Richard Montgomery taken by the author during a sonar survey of the vessel in June 1999. Note that the vessel's masts are visible above the water line. Consequently, an effective survey of the vessel can only be achieved during high spring tides.



Figure 6.2: The SS Richard Montgomery

6.2 The Survey

A detailed sonar survey of the Montgomery will take approximately half an hour and involves piloting the survey vessel as near to the shipwreck as possible at the highest possible tide. Special care must be taken by the vessel's captain not to strike the semi-submerged Montgomery, as the ship's payload is still highly explosive and could explode under impact. Consequently, all commercial ships must remain a distance of 200m from the shipwreck.

A detailed sonar survey of the wreck's surrounding seabed requires four hours, covering approximately 200m² of seabed. Alternative methods for surveying the Montgomery, for example, using divers or an ROV have proved nearly impossible due to the murky waters and dangerous underwater debris. Surveying the wreck using sonar provided the high-resolution raw sonar data for the WFM visualization.

6.3 Traditional Shipwreck Data Acquisition and Visualization Methods

Shipwreck and surrounding topographical data is generally collected using side scan sonar which was introduced to the reader in Section 2.6.4. Side scan sonar is an effective technique for initial wreck search activities. However, finding a shipwreck can prove to be an extremely complex and frustrating task. The sunken vessel may be large but it is still infinitesimally



Figure 6.3: Modern day photograph of the SS Richard Montgomery

small when hidden within its watery grave. Robert Ballard provides an excellent account of his search for the Titanic in Ballard et al. (1995).

After the vessel has been located, a detailed side scan survey will usually be initiated. Side scan can provide extremely clear and accurate images of the wreck. Note that the side scan images although very clear, are still limited to 2D. Some example side scan images of a ship wreck can be found in Section 2.6.4.

If the water is clear, ROVs may be used to gather high resolution video footage. Video cameras are mounted onto the ROV and carefully piloted down to the wreck. Piloting an ROV can be extremely difficult, especially as the ROV enters the wreck. This is due to the ROV's umbilical (containing fibre optic communications and power cables) snagging on items of debris. Figure 6.4 depicts the ROV Jason Jr. entering the wreck of the HMS Titanic. Note the large amount of debris obstacles that the ROV pilot must avoid.

Robert Ballard took thousands of high resolution photographs of the Titanic using ROVs. The water clarity was generally clear resulting in good quality images (Figure 6.5). By collating all the graphics together, he was able to produce an extremely accurate collage

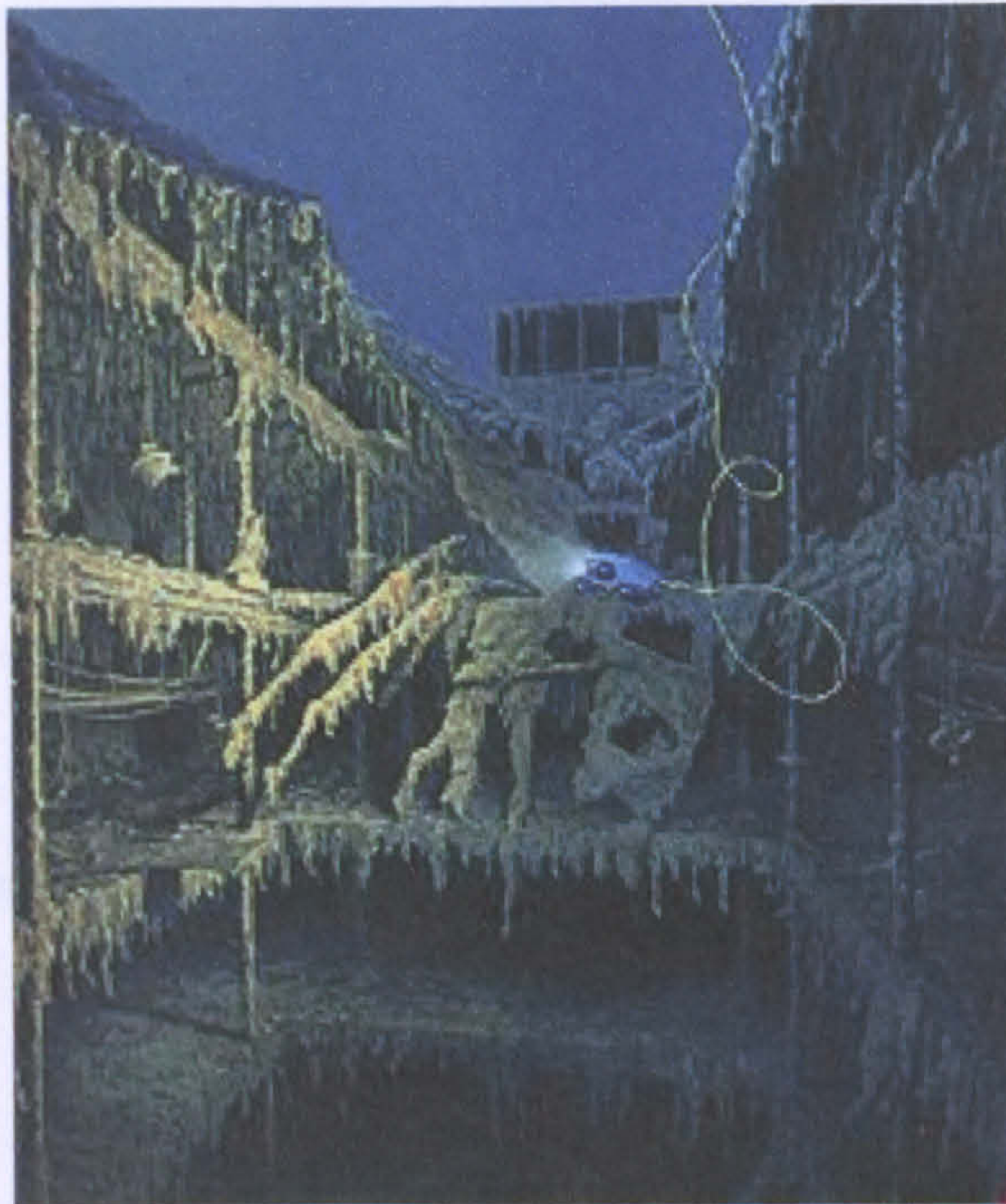

Figure 6.4: Ken Marshall's depiction of the ROV Jason Jr. entering the HMS Titanic of the wreck (Ballard et al. 1995).

Artists impressions can provide another important source for wreck site data interpretation. These images can be extremely useful although it is imperative that the artist's 'impression' is based on real data. Ken Marshall (one of the world's most renowned marine artists) used Ballard's ROV photographs in order to create a number of extremely accurate paintings of the stricken vessel. An example of his work is shown in Figure 6.4 and Figure 6.6.

Side scan and ROV video footage are the most popular methods for ship wreck data acquisition and visualization. The Oceanology conferences held in Singapore and Brighton provide a good indication of current market trends. Modern digital side scan sonar has dominated the conferences for a number of years and have proved to be extremely popular for gathering and visualizing shipwreck survey data. New side scan systems can record high resolution digital data and provide playback facilities to the user although paper charts still remain a popular form of presenting captured side scan sonar data¹.

¹Paper rolls of captured side scan data are still popular because a survey line can be rolled out along the floor or a desk enabling many people to study and make comments about the data.



Figure 6.5: ROV Video image of the HMS Titanic



Figure 6.6: Ken Marshall's depiction of the HMS Titanic

The shipwreck data acquisition and visualization discussed in this chapter uses SRD's SVS system in order to gain high resolution 3D bathymetric data over the wreck site. The wreck display can be improved by carefully registering an accurate CAD model of the vessel over the vessel's sonar returns.

6.4 Shipwreck Visualization Architecture

Figure 6.7 describes the WFM architecture used for visualizing the Montgomery shipwreck data. The model is similar to the example architecture introduced in Section 5.3.1 except that the shipwreck visualization architecture has been augmented to permit the overlaying of an accurate CAD model of the vessel directly over the corresponding bathymetric data from the model. This process (including the CAD file and Model Import module) is described in Section 6.5.2.

In Figure 6.7, the network element of the architecture has been omitted because with

6.5 Results

this particular survey, the BlueBox recorded all the data at survey time for post-survey visualization in the office.

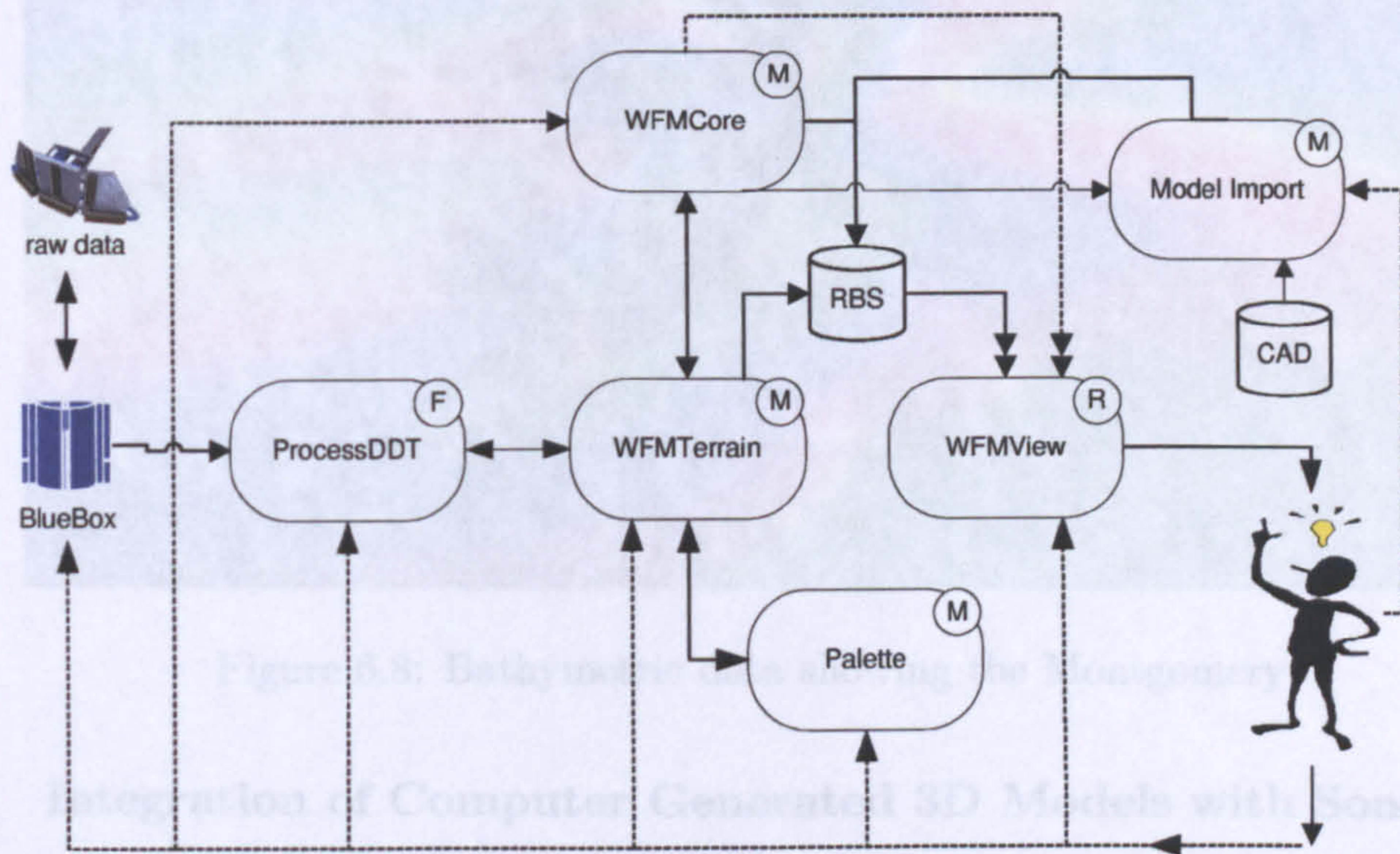

Figure 6.7: SS Montgomery Visualization Architecture

6.5 Results

This section considers WFM's performance based on the objectives defined at the beginning of this chapter.

6.5.1 Visualization of ε_2^s Bathymetric Data

Importing the bathymetric data into WFM produced a 3D interactive environment permitting the user to fly around the Montgomery investigating the wreck and areas of interest around the wreck.

WFM's visualization of the Montgomery survey data can be seen in Figure 6.8. The surrounding seabed topography can be clearly seen from the hypsometric hints. The user can adjust or scroll through the area at runtime using the Palette module to highlight seabed scouring or areas of interest. The high resolution of the data obtained means that slight changes in the condition of the vessel or the surrounding seabed topography can be easily identified.

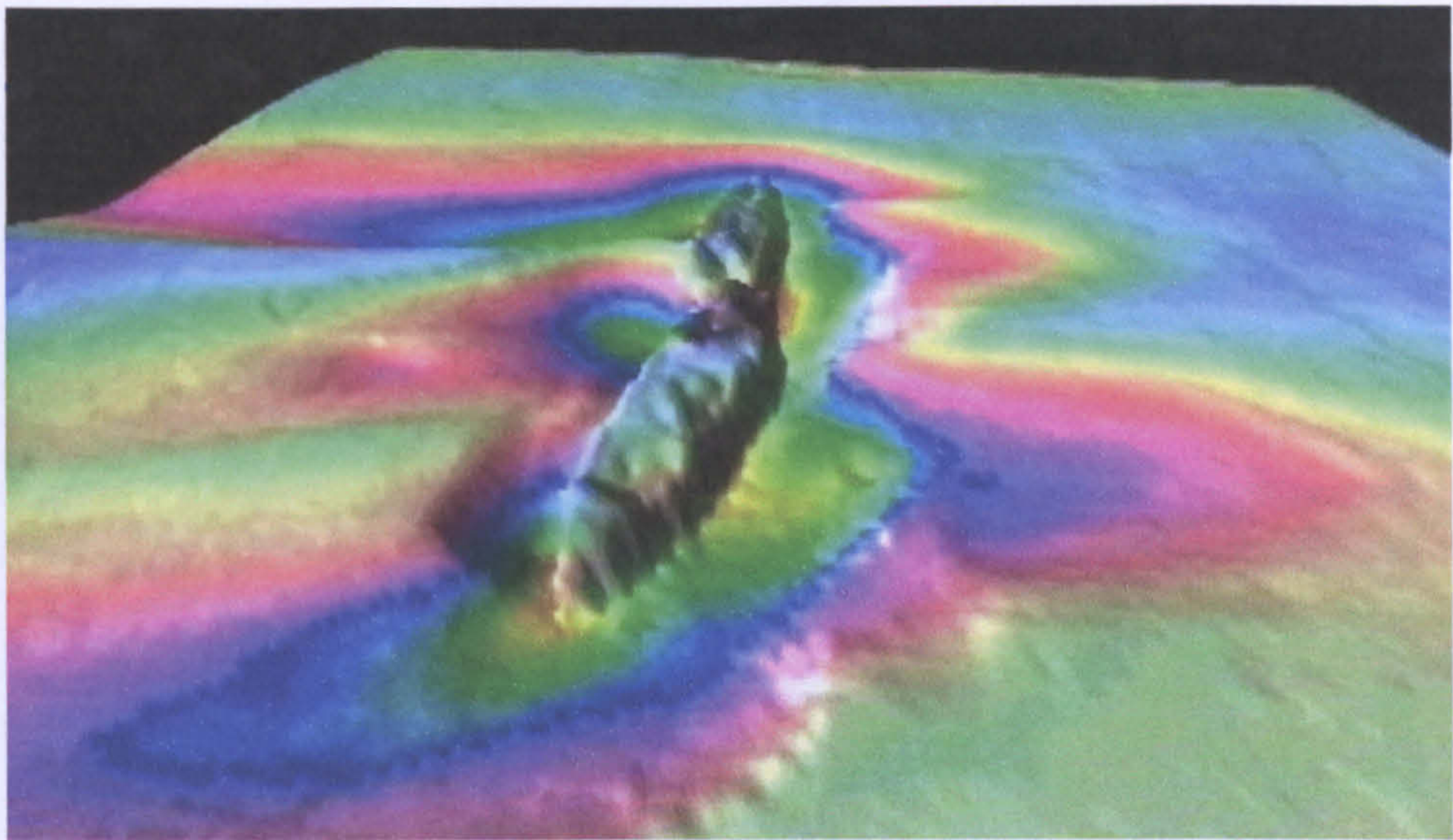

Figure 6.8: Bathymetric data showing the Montgomery

6.5.2 Integration of Computer Generated 3D Models with Sonar Data

Obtaining the original engineering drawings of the Montgomery permitted production of a 3D CAD model of the sunken vessel. This model was carefully overlaid onto the sonar model data set resulting in an effective visualization providing immediate comprehension of the vessel's position on the seabed. The model import module can be seen in the shipwreck architecture diagram (Figure 6.7). The CAD file holds the geometry of the Montgomery vessel and is the input to the Model Import mapping module. The Model Import module then creates the 3D geometry for the Montgomery and stores it within the RBS file consequently rendering the 3D model on the user's viewport via the WFMView module. The user can then move the CAD model in 6D in order to position the vessel accurately on the vessel's bathymetric surface. The results can be seen in Figure 6.9 and Figure 6.10.

6.5.3 Areas of Interest (AOIs) and Levels of Detail (LODs)

For an interactive viewing environment, it is important to keep the number of rendered polygons at a level that can be processed effectively by the graphics hardware. The more complex the scene, the slower the frame rate. The slower the frame rate, the more frustrating the display becomes for the end user.

Reasonable frame rates within this thesis have already been defined in the previous

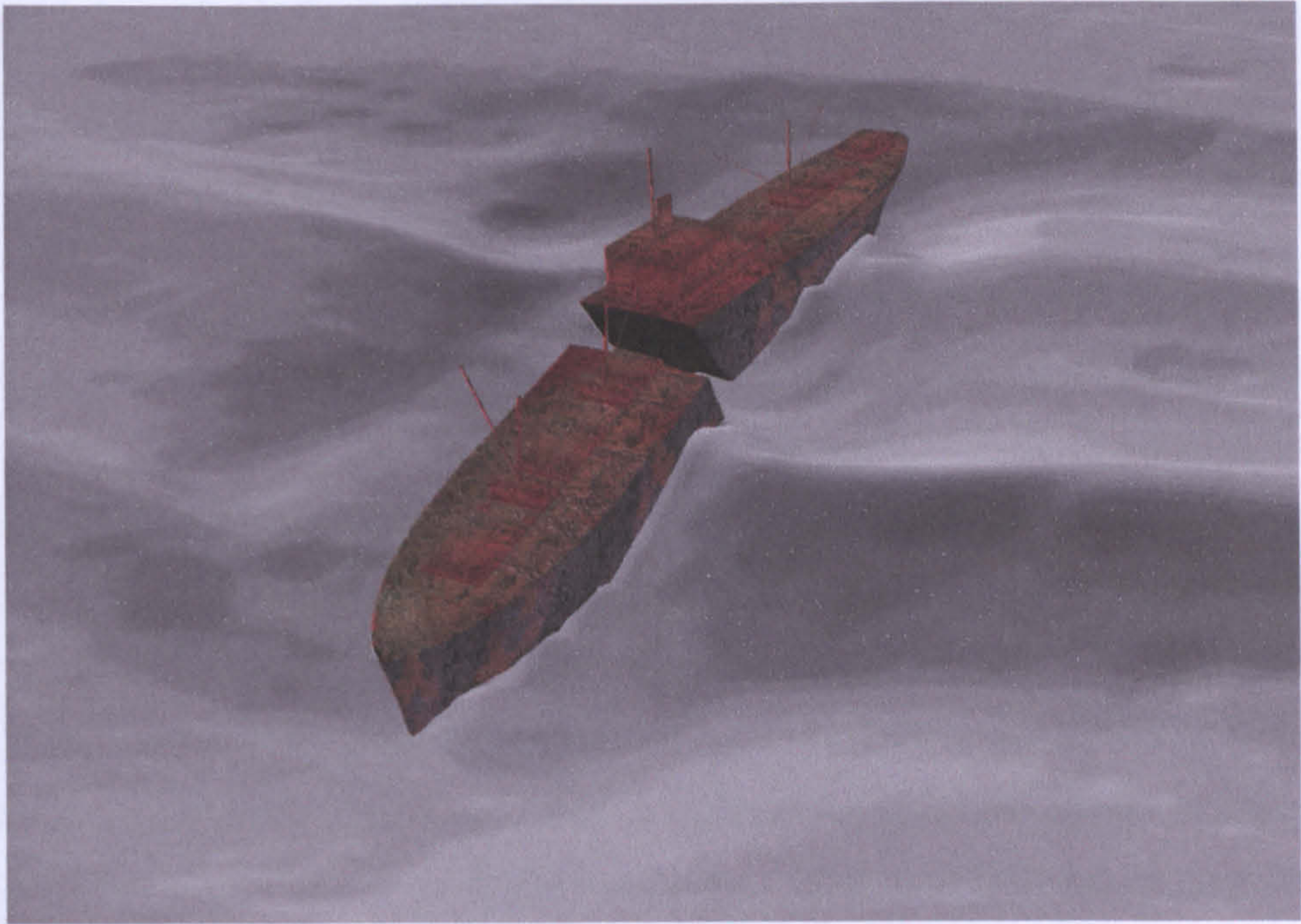

Figure 6.9: Bathymetric data with accurately positioned shipwreck model

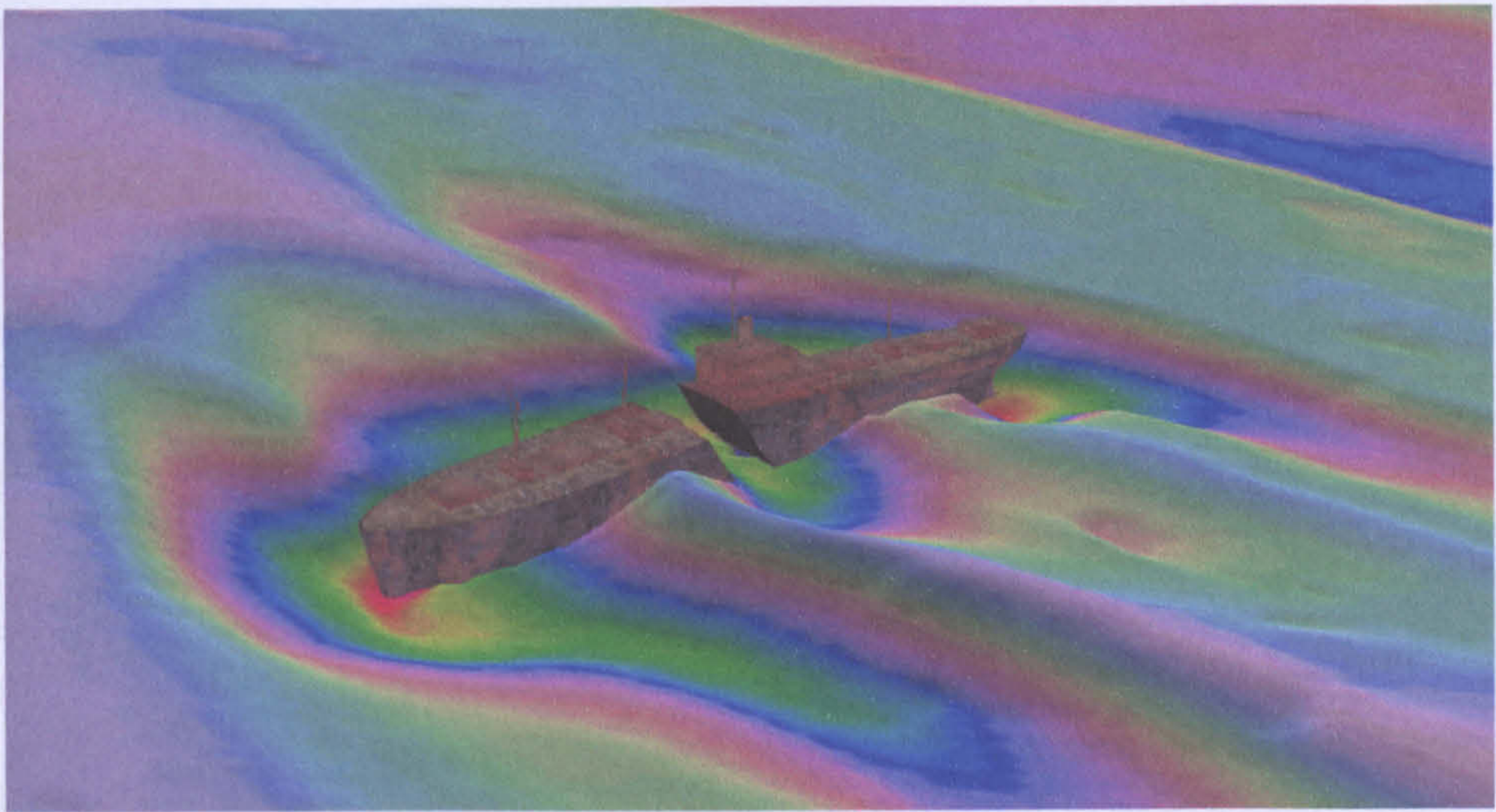

Figure 6.10: Colour image of wreck bathymetric data

6.5 Results

chapter as greater than 15fps².

Subsequently, two techniques, areas of interest and levels of detail were used to reduce the complexity of the high resolution rendered scenes.

Areas of Interest - AOI

Periphery areas that are not of interest do not need to be rendered at high resolution. Careful selection of areas of interest results in reduced polygon counts for an underwater scene resulting in higher frame rates. These AOIs can be selected by 'elastic banding' a definable rectangular area around a low resolution terrain model (displayed with WFMView). The WFMTerrain module can then extract and map terrain data at a user defined resolution using data from the original terrain maps³.

The most important terrain data collected from the Montgomery survey is the data relating to the shipwreck itself. Figure 6.11 shows how the user has defined an AOI around the ship and processed this at a higher resolution. This was achieved by providing the WFMTerrain mapping module with the bottom left and top right coordinates (two sets of Eastings and Northings) of the area of interest. The specified area of interest is then processed at a higher resolution as can be seen in Figures 6.11 and 6.12 which show two identical models rendered using Gouraud shading (Watt 1994) and wire-frame techniques respectively.

Levels of Detail - LODs

LODs reduce the strain on the graphics hardware by selective geometrical rendering. In the simplest case, and the one adopted by WFM, the complexity of an object is determined by the euclidian distance from object centre to camera.

WFM was developed so that objects of high resolution such as terrain are generated at both high and low resolution (within the WFMTerrain module). If the distance between the view camera and the centre of the 3D object exceeds a threshold, the high resolution model will be exchanged with the low resolution model. If a second threshold is exceeded, the model will disappear completely. An example of the relationship between distance and model resolution for rendering can be seen in Table 6.1

²Although ideally frame rates of between 20 and 60fps (SMPTE 1993) are preferred.

³The maximum resolution will be limited by the resolution of the digital terrain map.

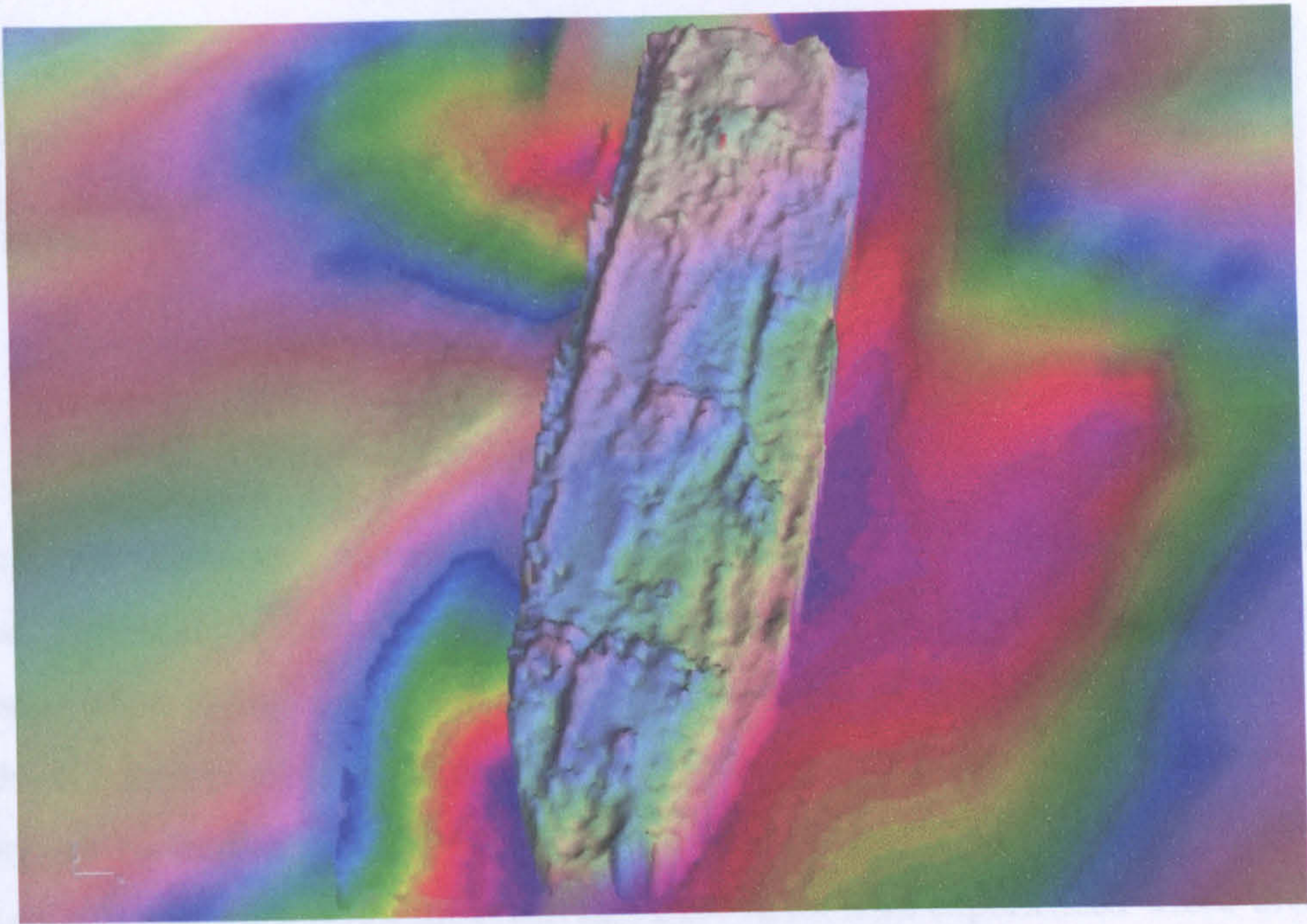

Figure 6.11: High resolution data shipwreck lying on a reduced resolution seabed

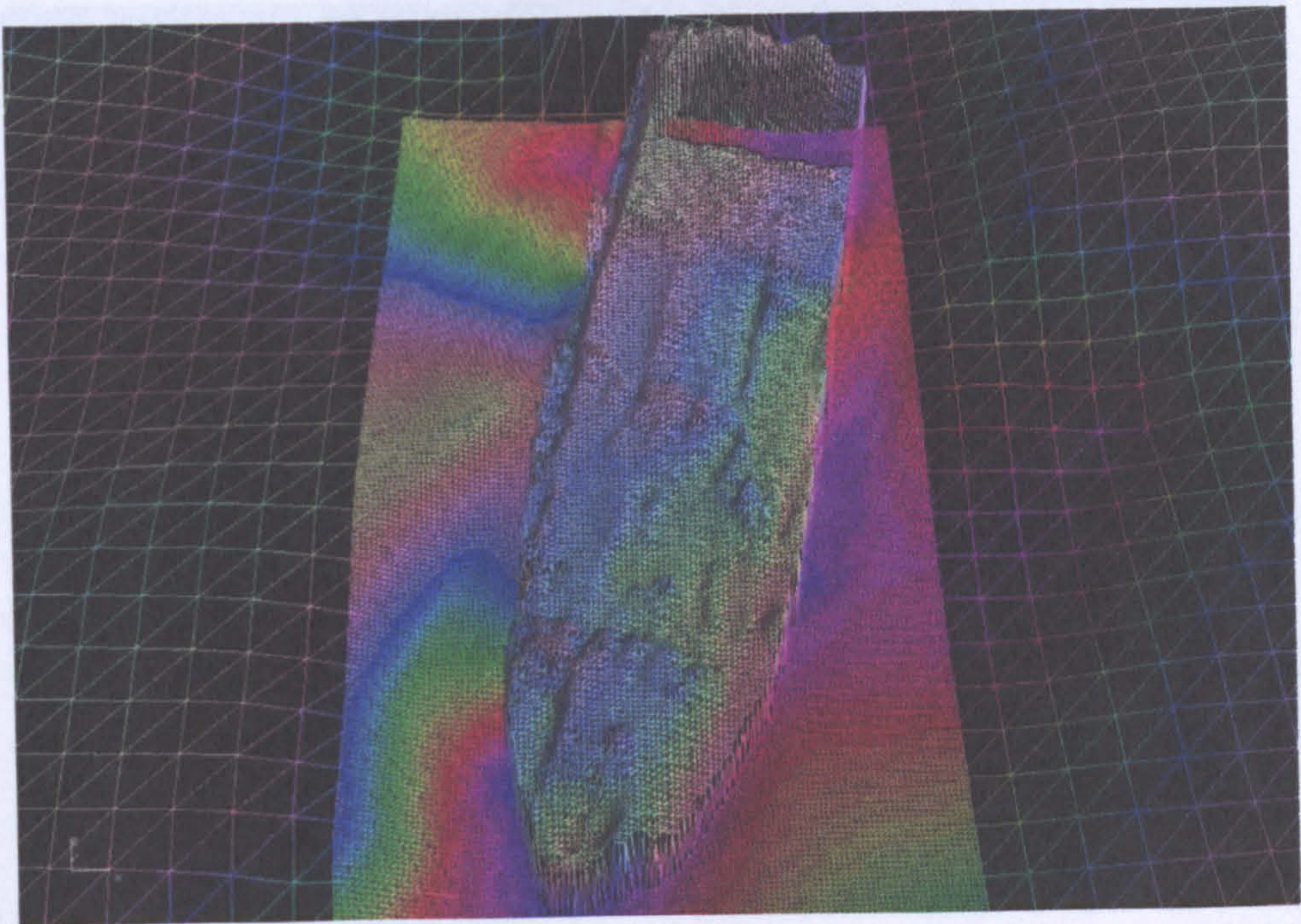

Figure 6.12: High resolution data shipwreck lying on a reduced resolution seabed (wire-frame)

Metre Distance (x) from camera to model centre	Object for rendering
$0 \geq x < 100$	High resolution model
$100 \geq x < 500$	Low resolution model
$500 \geq x$	No Model

Table 6.1: Example LOD settings

6.5.4 Realistic Underwater Rendering

In certain circumstances, a more realistic visualization of the underwater environment is required. For example, providing divers with an accurate model of what they may visually experience when diving a wreck. Improving the realism of the Montgomery visualization was achieved by replacing the hypsometric coloured seabed with a clay texture and adding a murky sea by implementing a fog algorithm (Woo et al. 1997) (Figure 6.13). Feedback on the scene's realism was obtained through interviews with experienced wreck divers such as Mr Iain Campion, a professional diver from Hull who has over 10 years wreck diving experience.



Figure 6.13: WFM Simulating a realistic underwater environment around the Montgomery wreck

Mr Campion stated that the underwater visualization provided a realistic underwater

6.6 Summary

atmospheric environment but lacked certain elements such as underwater caustic lighting effects and silt in the water which often gives a good indication of underwater currents. Underwater silt and currents could be incorporated into the WFM architecture using particle systems and underwater lighting can be implemented using textured caustic effects (DeLora 2000) but this was thought to be outside of WFM requirements.

6.5.5 User Interaction

A Microsoft Sidewinder joystick was used as the main tool for user interaction within the WFM system. The Microsoft joystick was selected because it was well constructed and was one of the few joysticks that incorporated torque (twisting the joystick around its vertical axis) thus providing the user with a more intuitive yawing function (change of heading). Although WFM also provided the user with the ability to roll the camera, it was noted that the user often became disorientated and confused while rolling. Trials with a disabled roll proved to be successful and consequently the 'up' vector for the camera was permanently fixed.

6.6 Summary

This chapter has described how WFM has provided an alternative method for viewing shipwreck survey data. Specifically data collected from the wreck of the SS Richard Montgomery. Traditional side scan survey techniques can only provide the viewer with a 2D bird's-eye photograph of the collected data. By using a single sweep continuous swathe system instead of a side scan system, real 3D bathymetric data can be imported directly into the WFM system enabling the user to fly around the underwater environment and select any viewpoint or area of interest.

It was interesting to note from this case study how effective colour texturing can be for seabed topography depth perception. Figure 6.9 and Figure 6.13 show quite low altitude viewpoints with a grey clay texture mapped seabed yet the undulating seabed topography is still clear due to the use of lighting and shading on the model. As the viewer increases their altitude and moves away from the vessel, it becomes more difficult to comprehend the topography and some form of coloured texturing is required. This can be clearly seen in Figure 6.10 (note the clearly defined dredged shipping channel in the top right hand corner

6.6 Summary

of the image).

Annual surveys are now undertaken to monitor the wreck's condition and changes in the seabed. The high resolution of the data obtained means that slight changes in the condition of the vessel or the surrounding seabed topography are easily distinguishable through comparative visualizations provided by WFM.

The aims and objectives of this case study have been satisfactorily completed. WFM has effectively visualized simple post-survey ε_2^g bathymetric data, geometrically reduced high resolution terrain maps and included precisely positioned CAD models of shipwrecks into the marine visualization. However, as mentioned previously in this chapter, this case study was quite trivial and was selected as a gentle introduction to marine visualization. It remained to be seen how WFM would evolve in order to meet increasingly complex requirements from other offshore activities.

Chapter 7

Harbour Wall Visualization

The aim of this chapter is to augment the architecture previously described in the shipwreck survey to handle multiple computer generated objects and to consider the visualization of three dimensional point data (ϵ_3^p).

The objectives of this case study are twofold:

1. Extend WFM's architecture for the visualization of ϵ_3^p sonar data.
2. Explore how multiple computer generated 3D models can be integrated and overlaid with sonar data.

Figure 7.1 shows the areas under evaluation within this case study.

7.1 Introduction

This case study describes how WFM has facilitated in the visualization of a harbour wall in Ijmuiden, Holland. The objective of this project was to survey the harbour wall shown in Figure 7.2 and manually overlay computer generated visible concrete blocks onto the corresponding sonar pings in order to create an accurate computer model of the harbour wall.

Like the Montgomery project, the sonar data collected from the survey was not visualized in real-time but was collected and recorded during the survey and returned to the office for processing and subsequent post-survey evaluation.

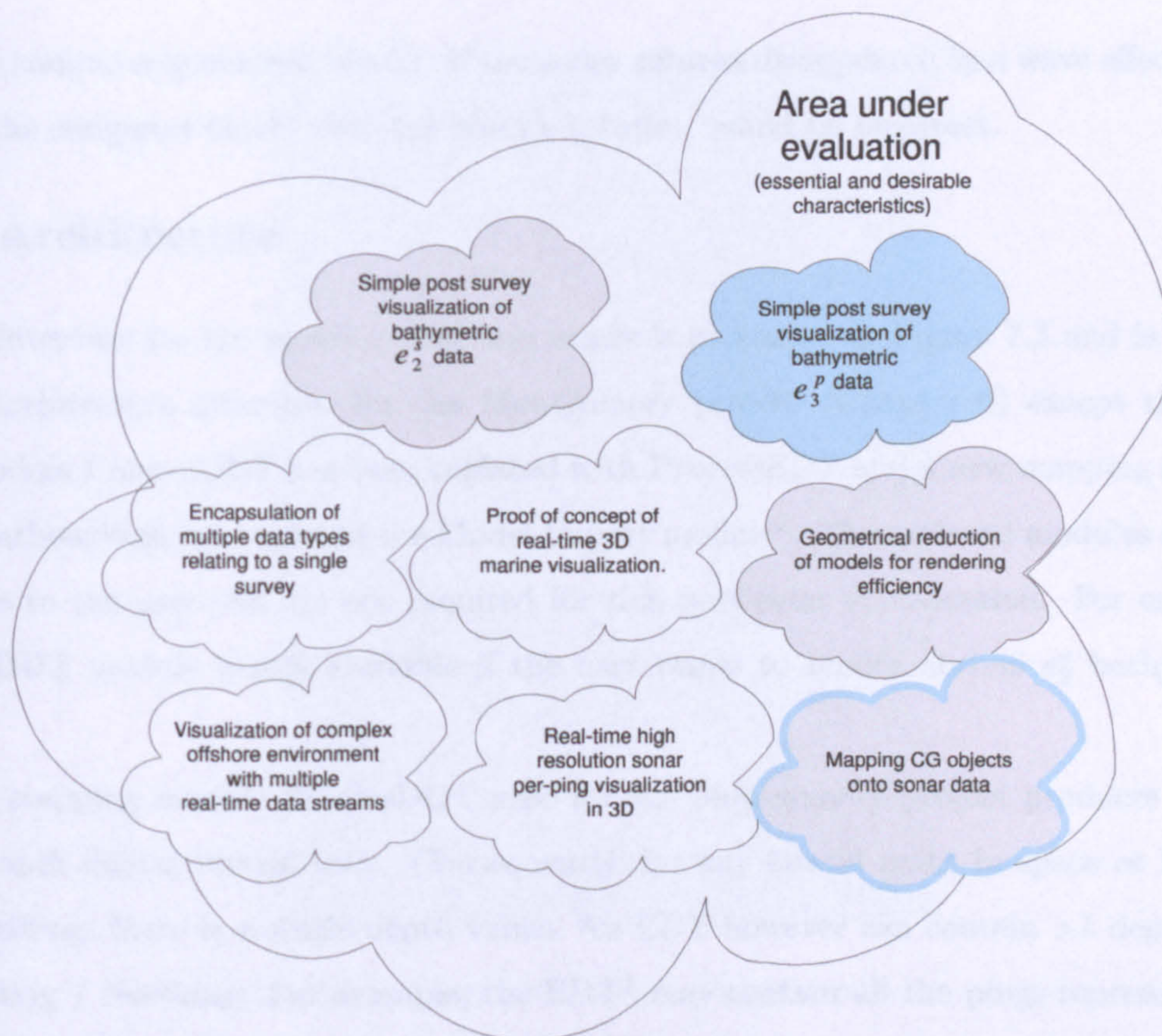

Figure 7.1: Area under investigation

7.2 Harbour Model Construction

The bathymetric data returned from the site survey served as input to WFM. The system rendered the 3D sonar returns on screen, allowing a clear view of the block positions. A semiautomatic program¹ then helped produce an initial map of the block's positions. However, it was also necessary to calculate the blocks' rotation (yaw, pitch, and roll). To do this, the author took advantage of the fact that the blocks themselves consist of planar faces. Simultaneously viewing both the sonar returns and the computer-generated blocks permitted the adjustment of each block so that its face coincided with the sonar returns. For example, assuming a computer-generated block was correctly positioned except for its depth. Then increasing the block's depth would result in the sonar returns representing the top face of the block disappearing simultaneously (as they will be perfectly coincident

¹A semiautomatic program was implemented due to the time restrictions associated with the case study. If more time was available, a fully automatic block registration system would have been implemented.

7.3 Architecture

with the computer generated block). If the sonar returns disappeared in a wave effect while raising the computer block, then the block's rotation would be incorrect.

7.3 Architecture

The architecture for the harbour wall case study is presented in Figure 7.3 and is similar to the architecture described for the Montgomery project (Chapter 6) except that the filter module ProcessDDT has been replaced with ProcessEDT and a new mapping module WFMHarbourWall has replaced the Model Import module². The replaced modules are still available to the user but are not required for this particular visualization. For example, ProcessDDT module is still available if the user wants to render normal ϵ_2^s bathymetric data.

The mapping module ProcessDDT used for the Montgomery project produces a minimum depth digital terrain map. Consequently, for any lateral point in space or Easting and Northing, there is a single depth value. An EDT however can contain >1 depth ping per Easting / Northing. For example, the EDT³ may contain all the pings representing a vertical block face. The extraction of these individual sonar pings (or points in 3D space) from the raw sonar data requires a new filter module ProcessEDT. ProcessEDT takes the raw sonar data and produces a file containing points (or Eastings, Northings and Depths) that can then be processed by the original WFM Terrain map module. By rendering all the data points, the user can register the computer model face with the sonar pings as described in Section 7.2.

A new module WFMHarbourWall was created for the generation and creation of the 3D harbour blocks. WFMHarbourWall provided the user with the necessary interaction to overlay computer generated blocks onto the ϵ_3^p data. The functionality required by the user was create, delete, select and position and orientate block.

7.4 Results

This section considers WFM's performance based on the objectives defined at the beginning of this chapter.

²The concept of writing and replacing modules was discussed in Chapter 5.

³Details relating to the EDT file structure can be found in Appendix A

7.4 Results



Figure 7.2: Photograph of blocked harbour wall at low tide

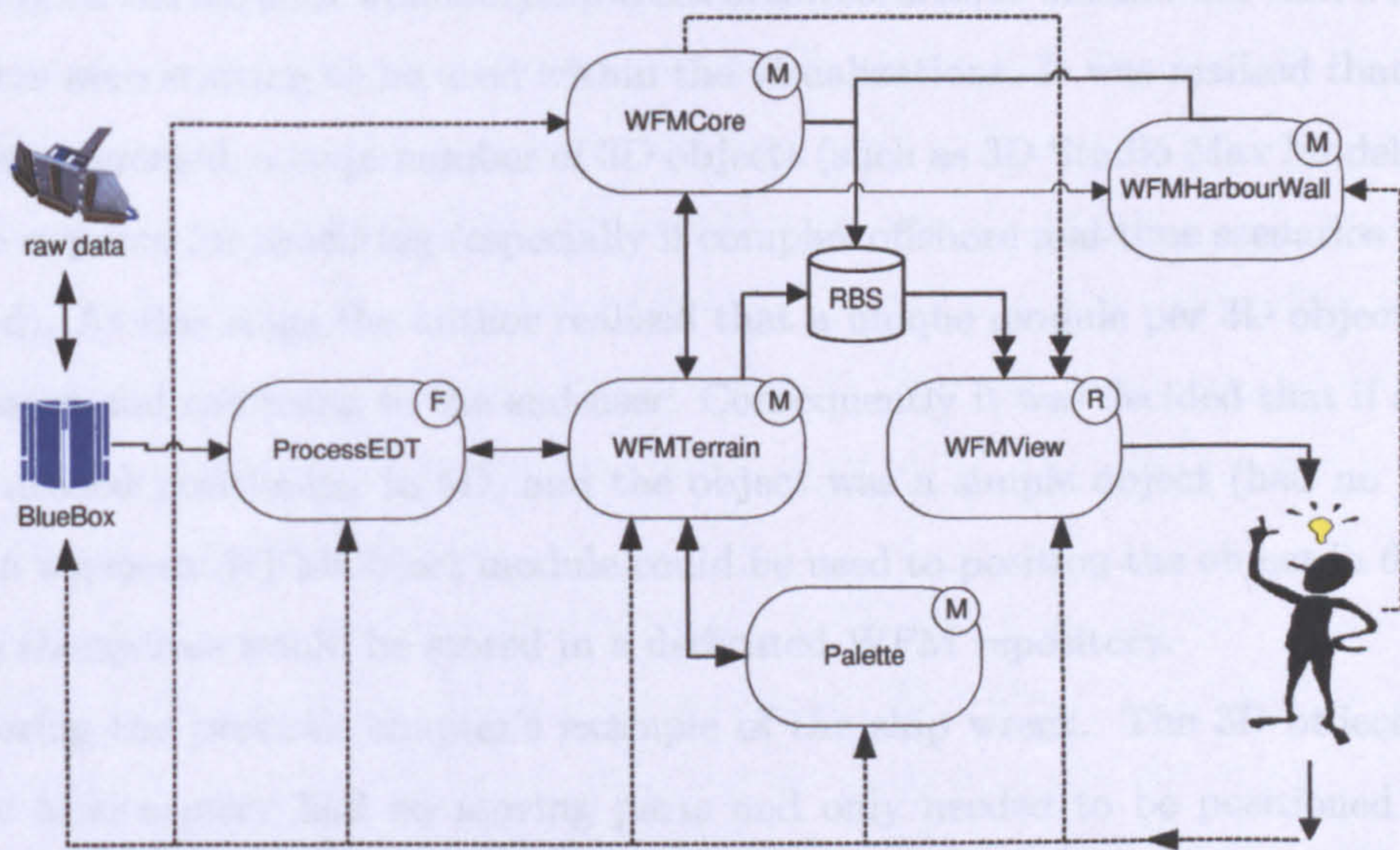

Figure 7.3: Harbour wall architecture

7.4.1 Extend WFM's Architecture for the Visualization of ϵ_3^p Sonar Data.

WFM was successfully modified to permit the visualization of ϵ_3^p data. This required a new ProcessEDT module and a modification to the existing WFMTerrain module in order to render point data (provided from the ProcessEDT module). The original Palette object was used to colour the individual sonar pings. WFMView's output resulting from the architecture modifications can be seen in Figure 7.4, Figure 7.5 and Figure 7.6.

7.4.2 Consider how multiple computer generated 3D models can be integrated and overlaid with sonar data.

Section 7.2 described how concrete computer models were mapped onto EDT point data for generating an accurate underwater model of a concrete harbour wall.

After the user has created the harbour model, the sonar pings may be turned off since the user no longer visually needs the sonar returns for the blocks. The software still renders the returns from the seabed to provide the viewer with an indication of the gradient approach to the blocks. The 40m stretch of harbour wall shown in Figure 7.4 took approximately thirty seconds for the survey vessel to acquire data. The post processing required to develop the computer model of the correctly positioned blocks required a further ten minutes.

Reflecting on the harbour wall and shipwreck architectures, it was noticed that a number of 3D objects were starting to be used within the visualizations. It was realised that as the case studies progressed, a large number of 3D objects (such as 3D Studio Max Models) were going to be required for rendering (especially if complex offshore real-time scenarios were to be modelled). At this stage the author realised that a unique module per 3D object would be unnecessary and confusing to the end-user. Consequently it was decided that if a single 3D object needed positioning in 6D, and the object was a simple object (had no moving parts), then a generic WFMObject module could be used to position the object in 6D. The 3D objects themselves would be stored in a dedicated WFM repository.

Considering the previous chapter's example of the ship wreck. The 3D object representing the Montgomery had no moving parts and only needed to be positioned in 6D. Therefore the previous architecture's Model Import module could be replaced with a WFMObject module dedicated to loading the Montgomery model from WFM's repository and setting its position and orientation.

7.5 Summary

There is however an exception to the rule. The harbour wall blocks that have been discussed in this chapter are themselves simple objects that have no moving parts. Yet multiple instances of a single module dedicated to each block would be unworkable (the offshore engineer would need to load a WFMObject module for each and every concrete block in the harbour wall). Therefore in certain circumstances dedicated modules are preferred. In the harbour model example, the user can interact with a large number of blocks via a single module interface. Consequently the harbour wall architecture will remain unchanged. However, the previous chapter's shipwreck architecture would be modified as described above (replacing the model import module with a generic WFMObject module).

7.5 Summary

This chapter has described the successful implementation of a harbour wall visualization using WFM. The user created a 40m stretch of harbour wall by registering computer generated blocks onto ϵ_3^p sonar data from a harbour wall in Ijmuiden, Holland. The user having created the model, was able to fly around the harbour wall viewing areas of interest using the WVMView interaction techniques described in the previous chapter.

The WFMCore, WFMPalette and WFMView modules have not been modified since the Montgomery chapter. Minor modifications were made to the WFMTerrain map module in order to create point geometry based on the newly constructed ProcessEDT module. Although this and the previous case study have been fairly undemanding from a visualization perspective, it should be noted that the architecture defined in Chapter 5 has successfully visualized the harbour wall marine data. Minor modifications to the architecture were made based on the findings of this chapter (detailed above). However, these two case studies have provided a solid architectural base foundation upon which to continue research into 3D visualization of offshore activities.

To the best of the author's knowledge, the WFM graphics described in this chapter are the first instance of an accurate sonar positioned 3D harbour wall visualization in the field of computer graphics. However, using the current system, the modelling of kilometers of harbour wall would be extremely laborious and time consuming based on the system's current requirement for user input to position and orientate the harbour blocks. Possible

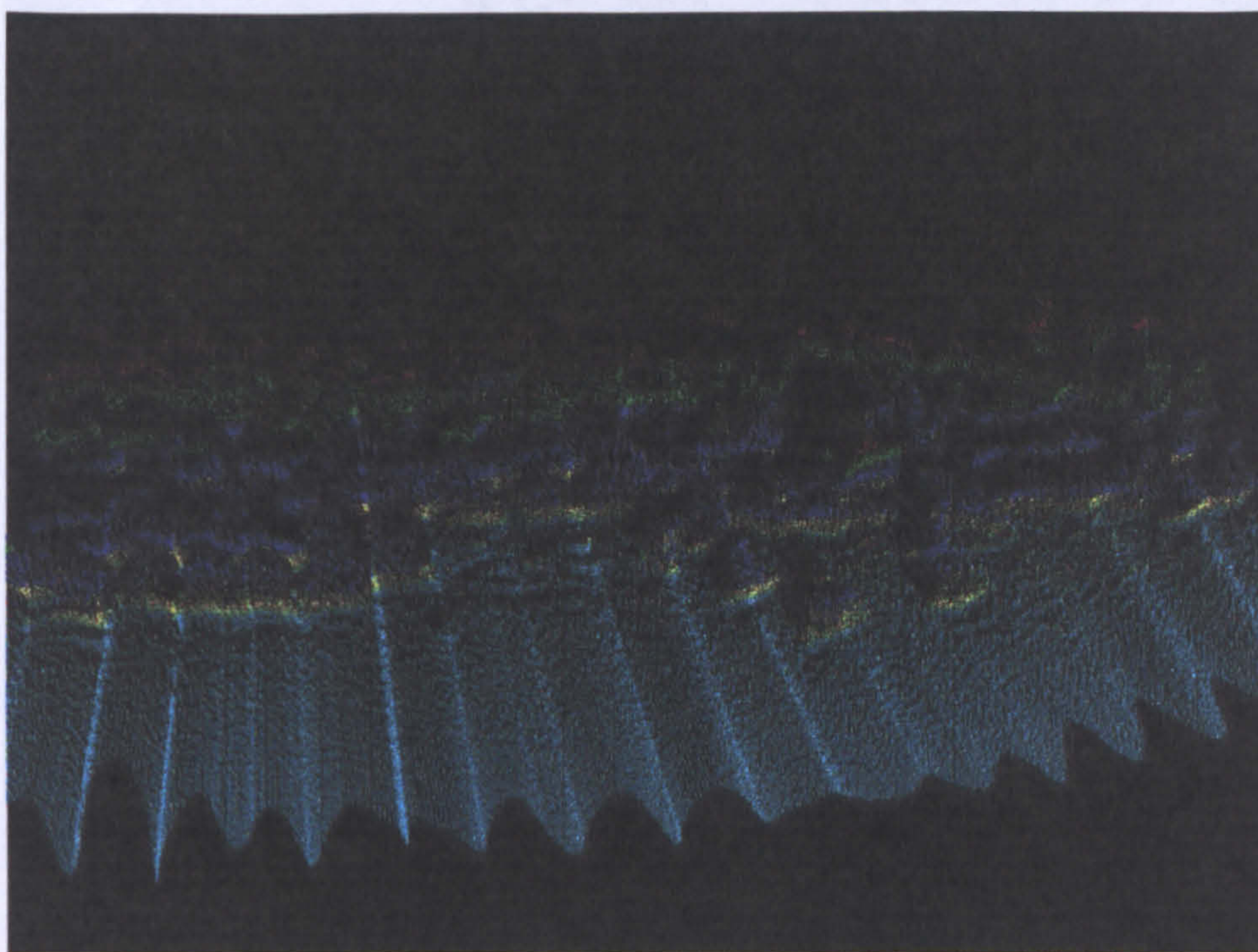

Figure 7.4: Harbour wall visualization EDT data

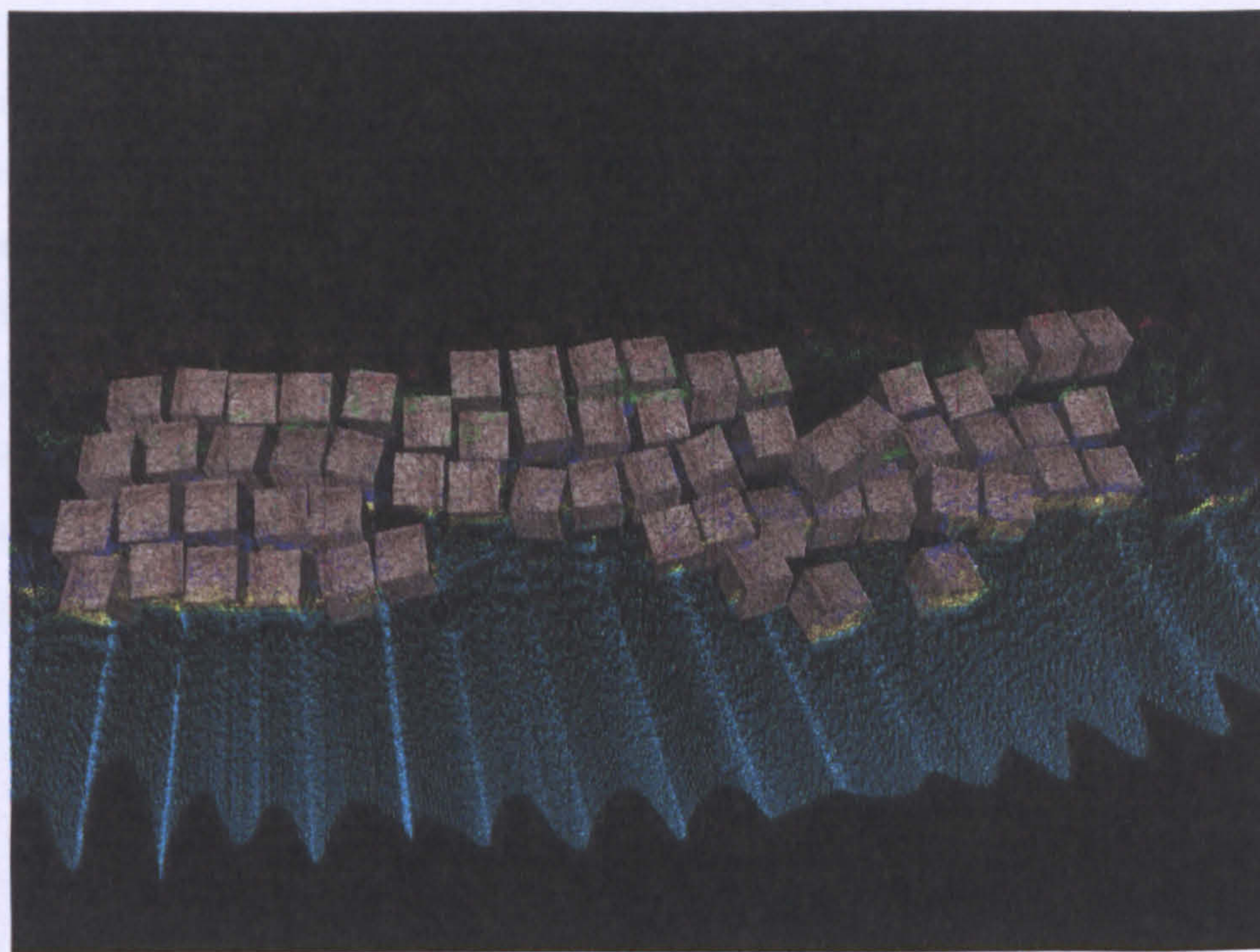

Figure 7.5: Harbour wall visualization

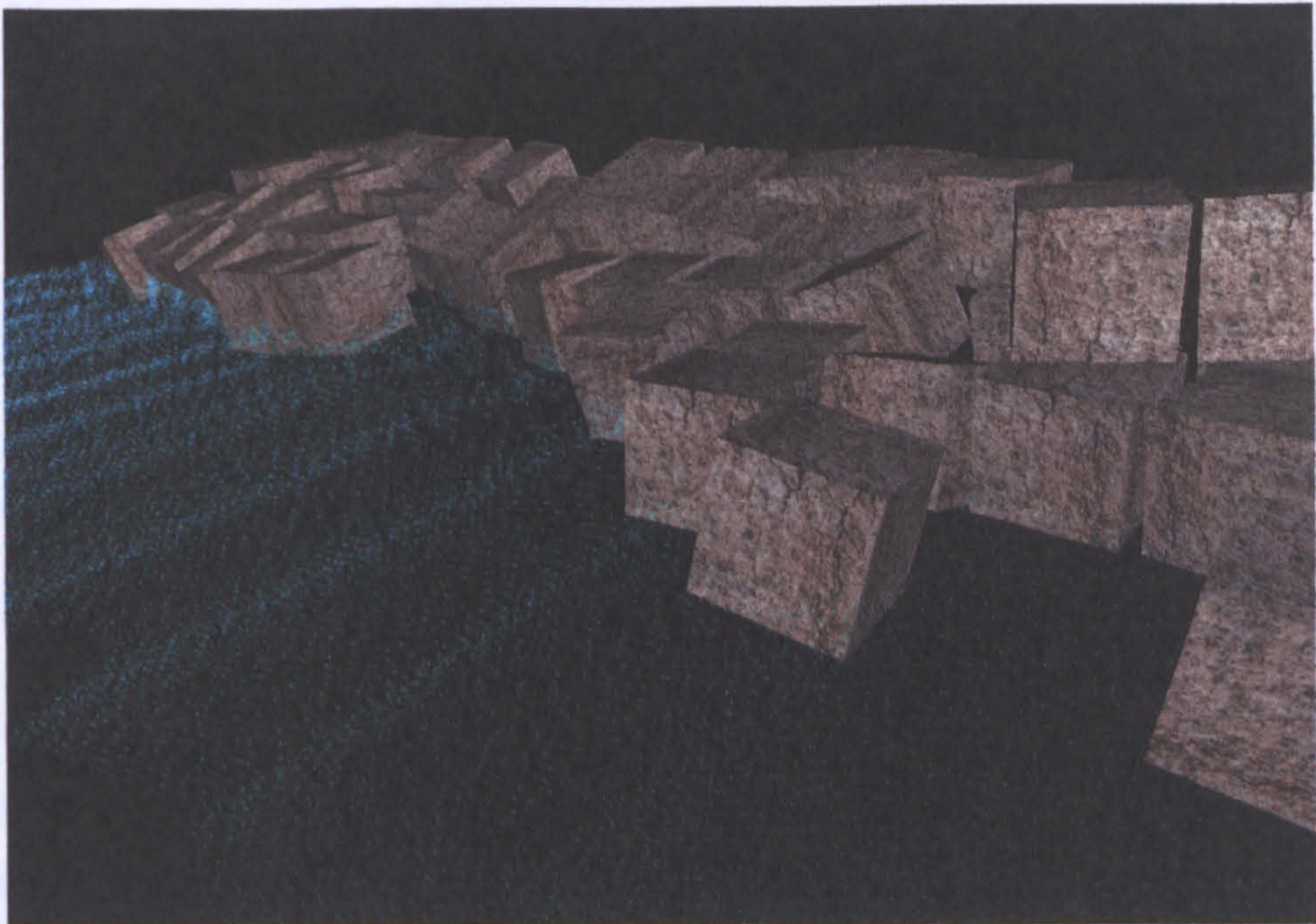

Figure 7.6: Virtual harbour wall environment

extensions to this work would involve automatic 6D registration of the computer modelled blocks with the sonar data. Design and implementation of such an algorithm was not possible due to the time constraints associated with the survey job.

Currently, surveying the harbour wall annually makes it possible to compare the data from previous years and monitor any block movement. A numerical comparison of a change in block attributes would suffice to monitor any change in position. However, a graphical representation showing an animated before and after scenario, letting the viewer watch the blocks slipping over accelerated time would be an extremely useful visualization tool. WFM could also be extended to animate predicted slippage by finding patterns in the data from previous surveys.

Chapter 8

Pipeline Visualization

The previous case studies have proved that WFM can visualize simple terrain sonar datasets and have successfully mapped 3D computer models onto the sonar data. The initial aim of this chapter is to consider how multiple data types relating to a single survey can be incorporated into a single visualization system. The second aim of this chapter is to implement a real-time visualization feasibility study based on a relatively uncomplicated offshore activity (described below).

Two pipeline visualization case studies were chosen to consider these aims. The first case study (Section 8.4) describes post-survey pipeline visualization focussing on the visualization of multiple datasets relating to underwater pipelines. Pipeline activities were selected for this case study because a survey can provide a rich assortment of datasets relating to a single section of pipeline¹.

Section 8.5 describes real-time marine visualization related to a pipeline dredging survey. The pipeline dredging survey was selected for integration with WFM due to the small survey area and the small number of moving objects.

Figure 8.1 gives a graphical depiction of the areas under investigation within this case study.

The objectives of this case study are fourfold:

1. Visualize 3D pipelines based on ϵ_2^s bathymetric and SBP data.
2. Encapsulate multiple data types relating to a single survey into a single interface.

¹Examples include bathymetric data, SBP data, ROV video footage, side scan data etc.

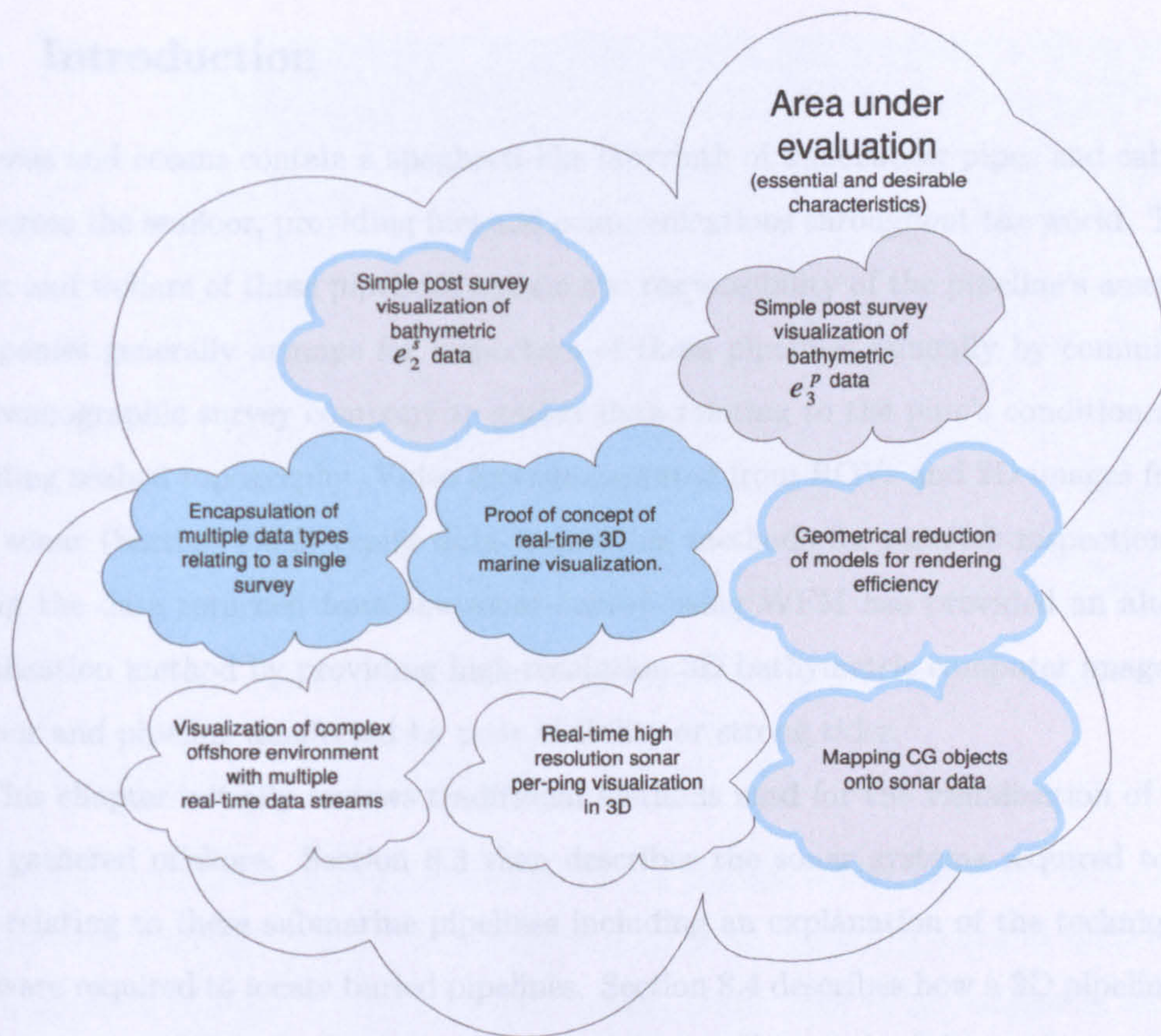

Figure 8.1: Area under investigation

3. To investigate the inclusion of virtual objects into the sonar computer generated model.
4. To investigate the feasibility of a 'real-time' WFM marine visualization.

The first three objectives are related to the first half of this chapter, post survey pipeline visualization (Section 8.4). The final objective is related to the second half of this chapter which is dedicated to real-time pipeline visualization (Section 8.5).

8.1 Introduction

Our seas and oceans contain a spaghetti-like labyrinth of underwater pipes and cables that criss-cross the seafloor, providing fuel and communications throughout the world. The condition and welfare of these pipelines remain the responsibility of the pipeline's asset owner. Companies generally arrange for inspection of these pipelines annually by commissioning an oceanographic survey company to gather data relating to the pipe's condition and surrounding seabed topography. Video footage captured from ROVs and 2D images from side scan sonar (Section 2.6.2) typify data acquisition methods for pipeline inspection. Visualizing the data returned from the sonar survey using WFM has provided an alternative visualization method by providing high-resolution 3D bathymetric computer images of the seafloor and pipeline unaffected by poor visibility or strong tides.

This chapter initially reviews traditional methods used for the visualization of pipeline data gathered offshore. Section 8.3 then describes the sonar systems required to gather data relating to these submarine pipelines including an explanation of the techniques and hardware required to locate buried pipelines. Section 8.4 describes how a 3D pipeline model can be constructed from the collected survey data and a method for coping with buried pipeline occlusion is also considered. The section then considers how hotlink facilities can be used to interface to various datasets relating to the underwater pipelines. A method for validating the visualizations by correlating the computer generated model with unambiguous ROV video footage is described in Section 8.4.4. and the data flow architecture required for this multimedia pipeline system is described in Section 8.4.5.

The first implementation of WFM for real-time marine visualization is illustrated in Section 8.5. The section describes how real-time marine visualization has been used to effectively provide new visual information to the pilot and crew of a dredging vessel. The section concludes by describing the necessary architectural modifications required for real-time marine visualizations.

Section 8.6 summarises the chapter's findings and considers how real-time marine visualization can be further extended to more complicated offshore activities.

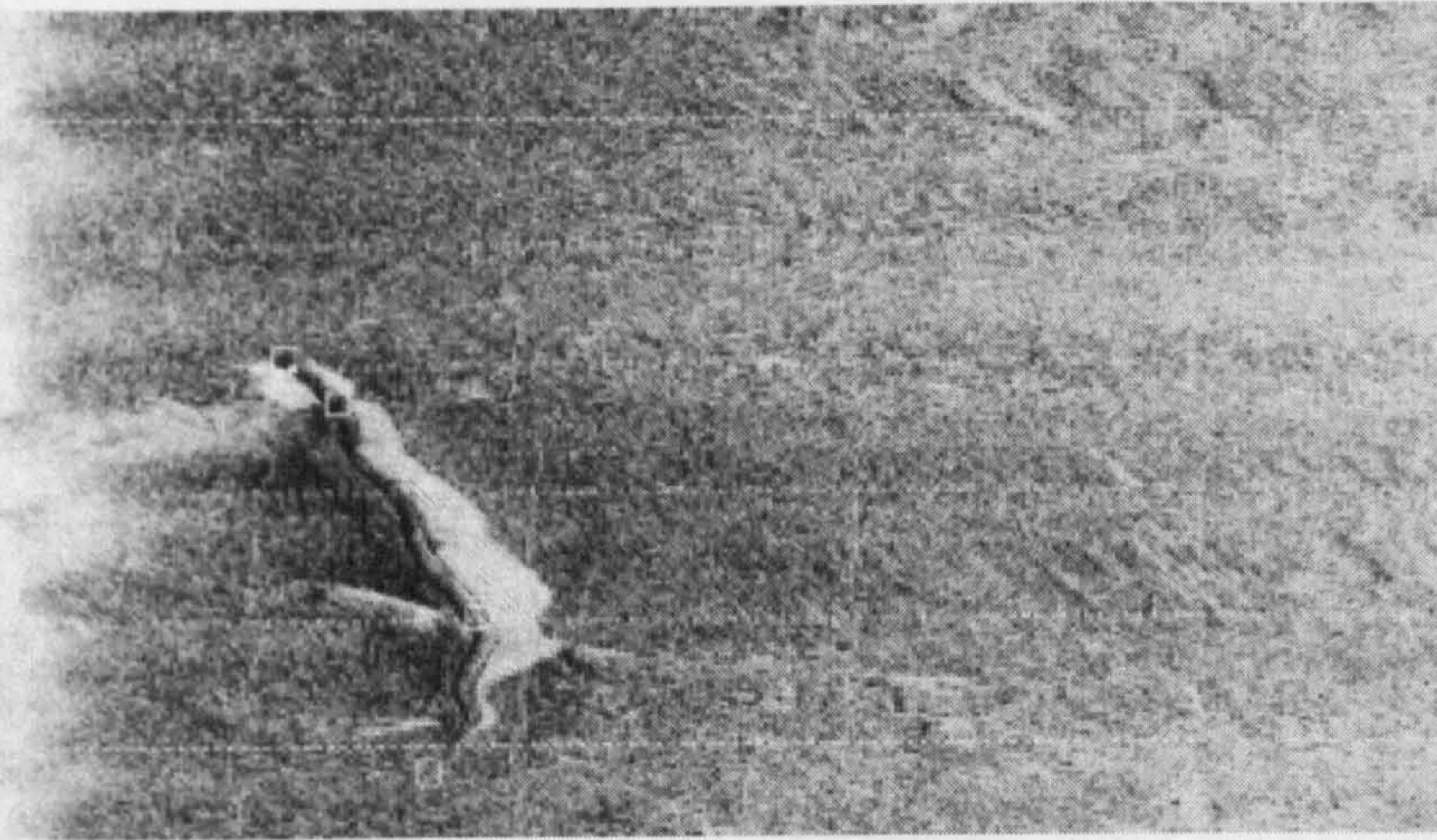

Figure 8.2: Side scan image showing a free-spanning section of pipeline

8.2 Traditional Visualization Methods

Traditional methods for presenting the data from a pipeline survey typically consist of reams of hard copy paper printouts. A popular technique for gathering pipeline survey data is side scan sonar (Section 2.6.4). Side scan results are limited to 2D images of the seabed surface (Figure 8.2). For true 3D data to be gathered, swath bathymetry sonar systems are required to gather 3D bathymetric data (Section 2.6.4).

3D information such as pipe depth and seabed bathymetry are generally displayed on paper charts in the form depicted in Figure 8.3. The top two images show cross-sections of the pipeline. The middle section shows a longitudinal section of pipeline and the bottom graphic depicts a bathymetric colour coded depth plot.

Learning to interpret these charts is not trivial and requires a reasonable amount of expertise. One of the objectives of this research was to investigate the integration of pipeline and bathymetric terrain survey data for visualization within WFM and to report on any advantages of visualizing the data in WFM's interactive 3D environment.

8.3 Pipeline and Peripheral Seabed Data Acquisition

Figure 8.4 shows the transducer configuration used for the pipeline inspection process, which uses three transducer arrays. The centre transducer, used in a high-resolution mode, at a range of 30m gathers data from a 15m-wide section of seabed. The two outer transducers

8.3 Pipeline and Peripheral Seabed Data Acquisition

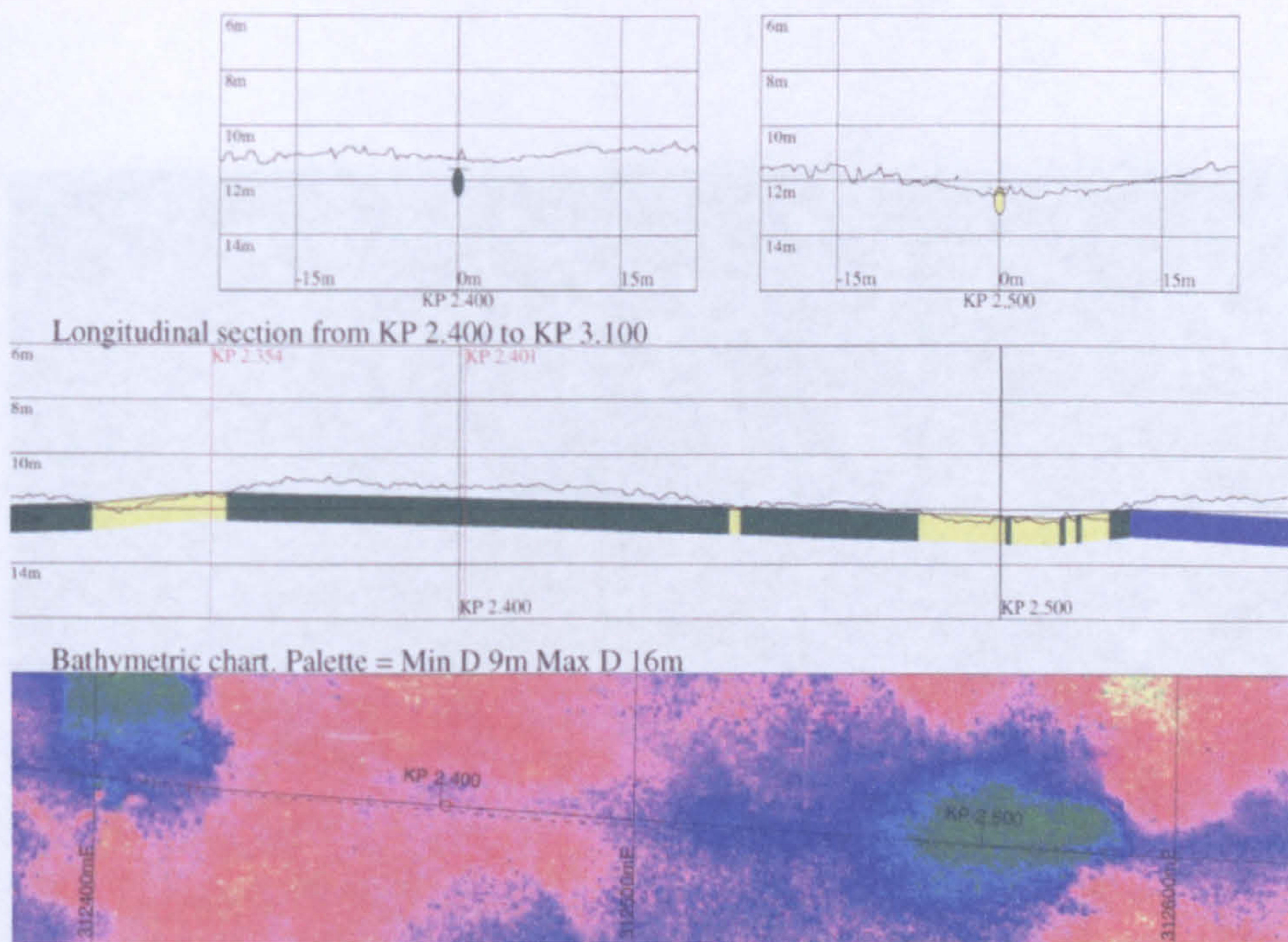

Figure 8.3: Pipeline survey paper chart

can also run in the high-resolution mode, but are more likely to use a wider coverage mode providing samples within a corridor at least three times water depth and possibly up to five times water depth. The frequency of the transducer arrays can be changed during the survey.

A section of underwater pipeline may occupy one of three categories: buried, exposed, or free-spanning. Pipeline cross-sections for each of these categories can be seen in Figure 8.5. A buried pipeline will stay fixed in its position, protected from the harsh underwater environment. However, as strong underwater currents scour the seabed, sections of pipeline become exposed. Further seabed scouring can remove all support from beneath the pipeline, leaving the pipe free-spanning. Those persons responsible for a pipeline's welfare need to identify exposed and free-spanning pipelines as quickly as possible because an increased strain on the pipeline will increase the probability of a pipeline fracture.

If a section of pipeline is buried, it will remain invisible to the transducers as the sound energy is reflected directly off the seabed surface. To calculate the position of a buried pipe a lower frequency seismic sub bottom profiler or SBP system (Section 2.6.4) is used

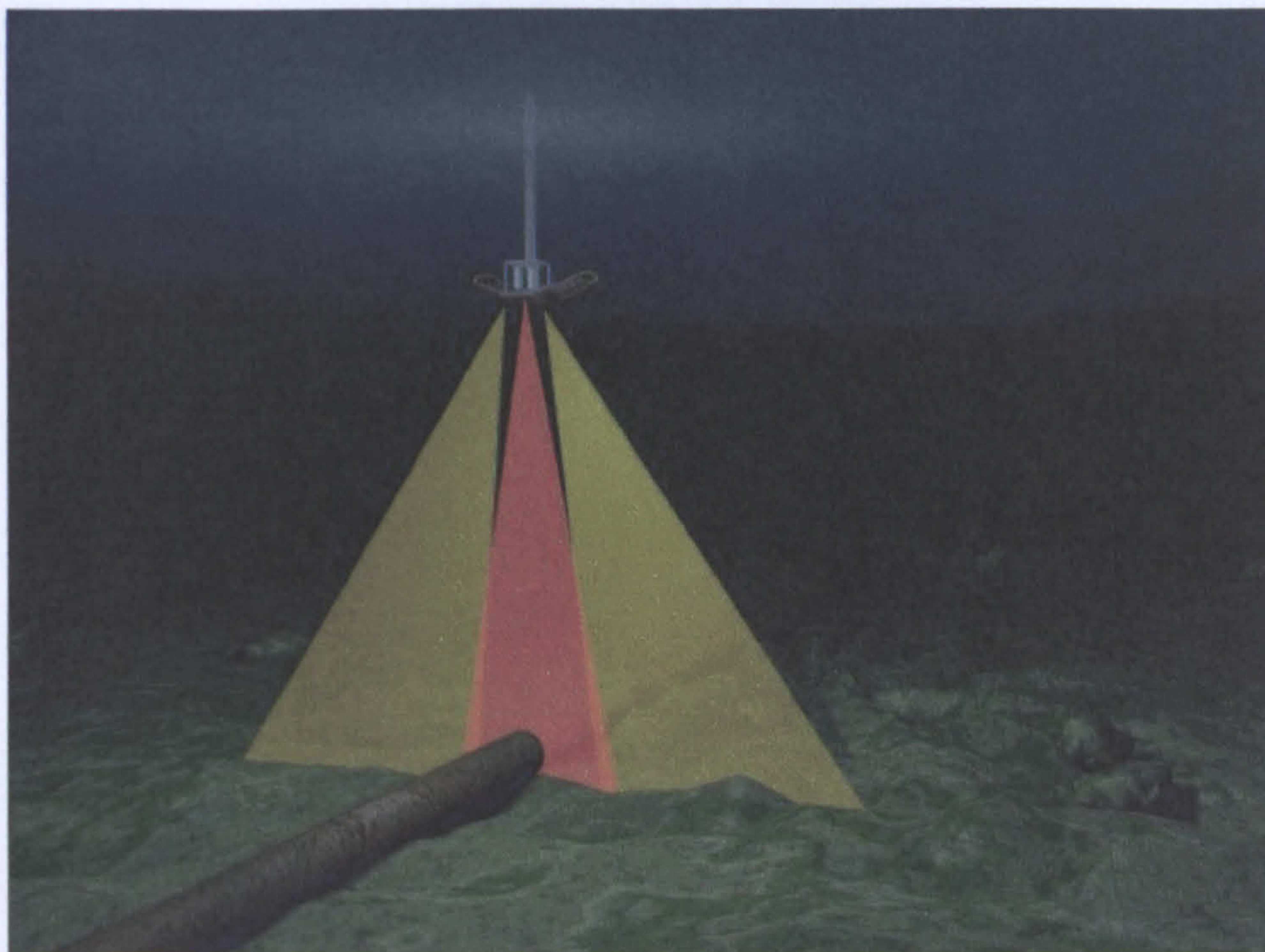

Figure 8.4: Typical transducer configuration for pipeline survey

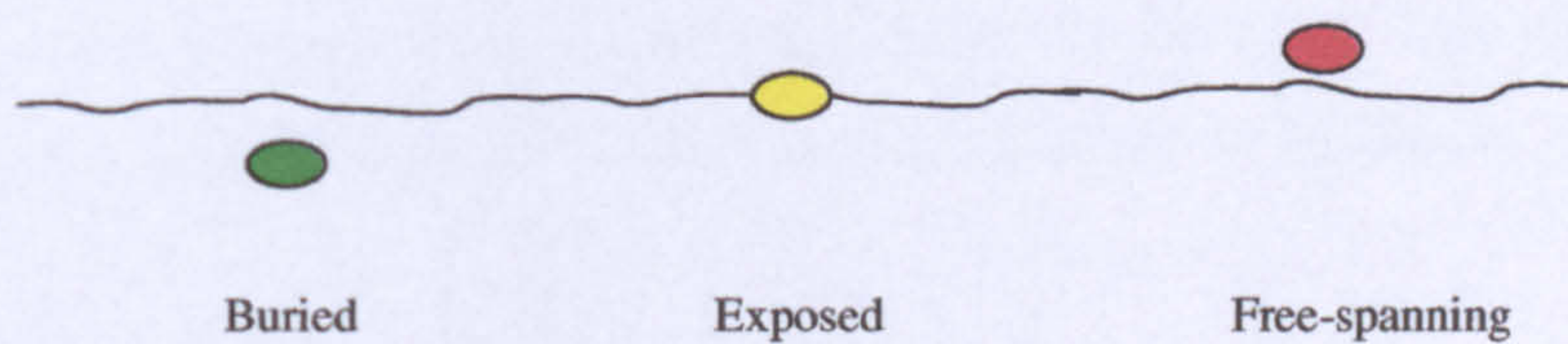

Figure 8.5: Pipelay categories

8.3 Pipeline and Peripheral Seabed Data Acquisition

which penetrates through the seabed surface and reflects off the hard concrete coating of the pipeline. The gathered pipeline positional data is then used to generate a virtual model of the pipe.

8.4 Post-survey Pipeline Visualization

This section describes how WFM was used to visualize data gathered from a pipeline survey. Consideration is given to 3D pipeline model generation that can be combined with 3D bathymetric terrain. Cross-section displays are also considered as a method for coping with occluded buried pipelines.

8.4.1 3D Pipeline Model Generation

Section 8.3 described the methods used to gather positional data relating to a section of pipeline. This information is stored in a pipe information file or PIF². The PIF file contains all the necessary information for generating a 3D model of the pipeline. Specifically, positional data, pipeline diameter (including concrete coating) and the data source (SBP, bathymetric sonar or client etc). Positions along a section of pipeline are identified using a 'Kilometer Pointer' or KP marker. The KP pointer is an unambiguous reference point along the pipe. For example, KP 6.7 represents 6,700m from the beginning of the pipe.

The equations and transformation matrices required for scaling, rotating and translating a section of pipeline are described in Appendix A. These pipeline sections can then be concatenated together to form a continuous 3D pipeline model. A buried pipe section however is occluded by the seabed and therefore extra provision needs to be made for the viewer.

The problem of occluded buried pipes can be overcome through the use of cross-section displays. Initially two positions must be calculated that are orthogonal to the direction of the pipeline at a given point. A linear interpolation can then be performed between these two points and cross-referenced to the associated digital terrain map. The transformation matrix for calculating the cross section extremities is described in Appendix A.

²PIF: Pipe Information File, not to be confused with the graphics file format .PIF.

8.4 Post-survey Pipeline Visualization

8.4.2 Post-survey Summary and Results

This section considers WFM's performance based on the post-survey objectives defined at the beginning of this chapter.

Visualize 3D Pipelines Based on ϵ_2^s Bathymetric and SBP Data

It is now possible to merge bathymetric seabed terrain and pipeline data into a single 3D display. Figure 8.6 shows a section of pipeline that has been imported with bathymetric terrain data. The pipeline runs along the seabed and constantly changes state between buried, exposed and free-spanning. An exposed or free-spanning section of pipeline may be clearly seen by the viewer.

A sample cross-section display can be seen in the top-right-hand corner of Figures 8.6, 8.7 and 8.8. The spheres or markers along the pipe in the main display show the reference point for the cross-section. The markers can be controlled by the user and can be moved forward, backward and locked to view so that the user may fly along a section of pipe with the cross-section updated dynamically.

The interactive nature of WFM's pipeline display allows the user to fly around the underwater database and view areas of interest. Figure 8.8 shows a section of pipeline freespan (the pipeline is unsupported by the seabed). This is evident both from the main 3D display and from the cross-section display in the top right hand corner.

Encapsulate multiple data types relating to a single survey into a single interface

The fourth high-level requirement described in Section 4.4 for an effective seabed visualization system for WFM was the seamless integration of multiple and disparate data types into one succinct user interface. Examples of disparate data associated with pipeline surveys may include ROV video footage and SBP parabolic graphics showing buried pipelines.

8.4 Post-survey Pipeline Visualization

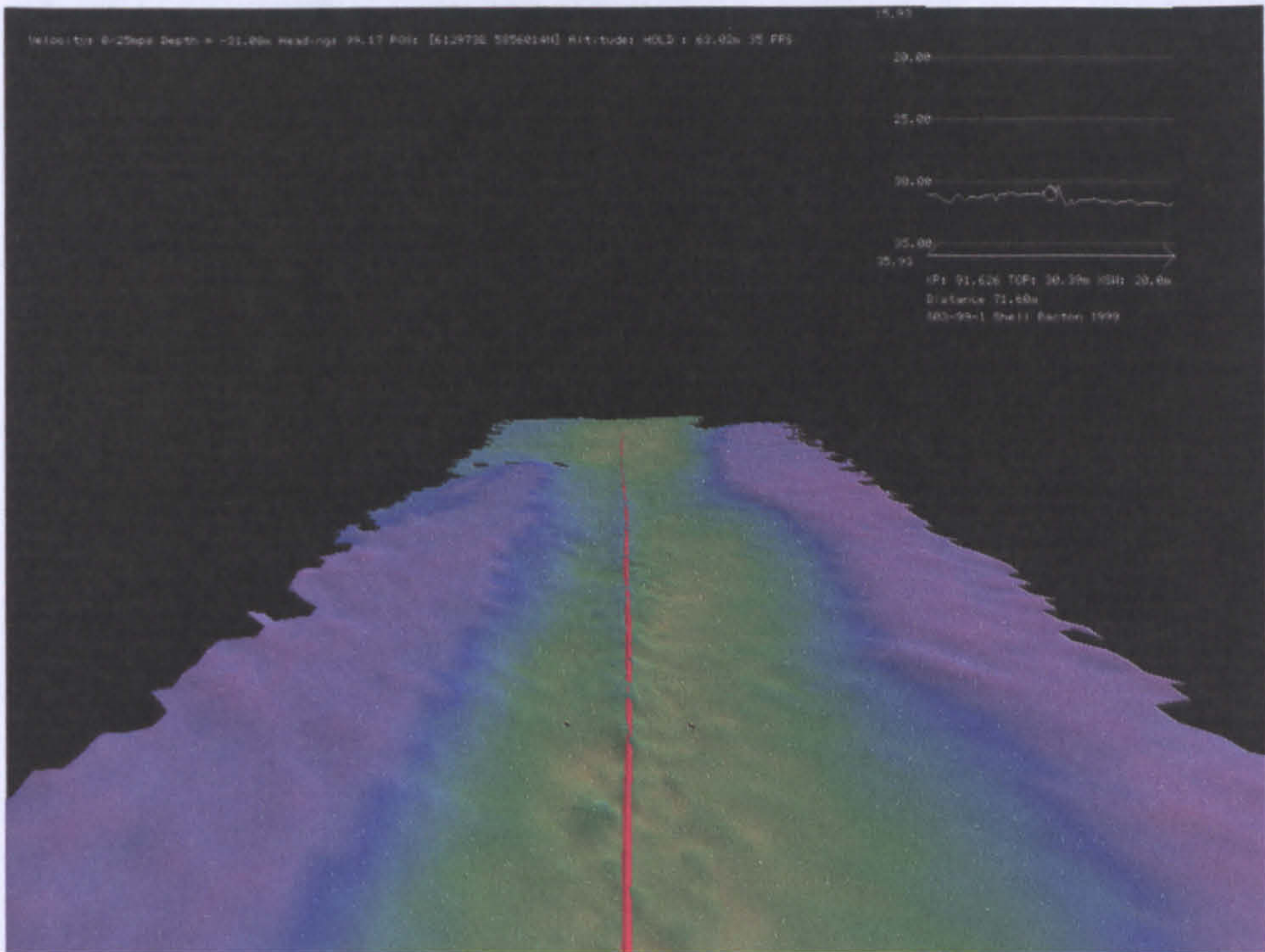

Figure 8.6: Exposed pipeline section

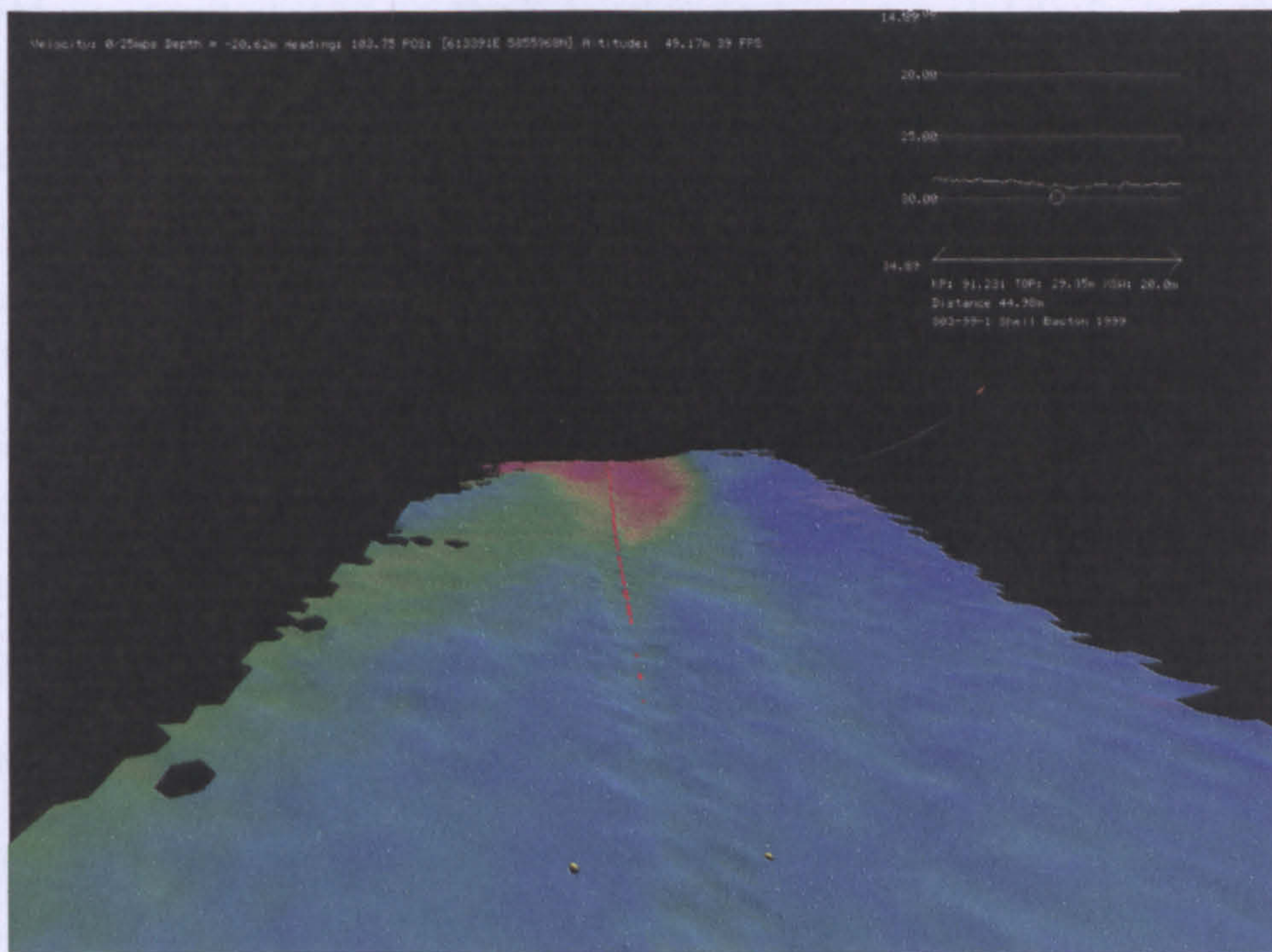

Figure 8.7: Buried pipeline section - Visible from the cross-section

8.4 Post-survey Pipeline Visualization

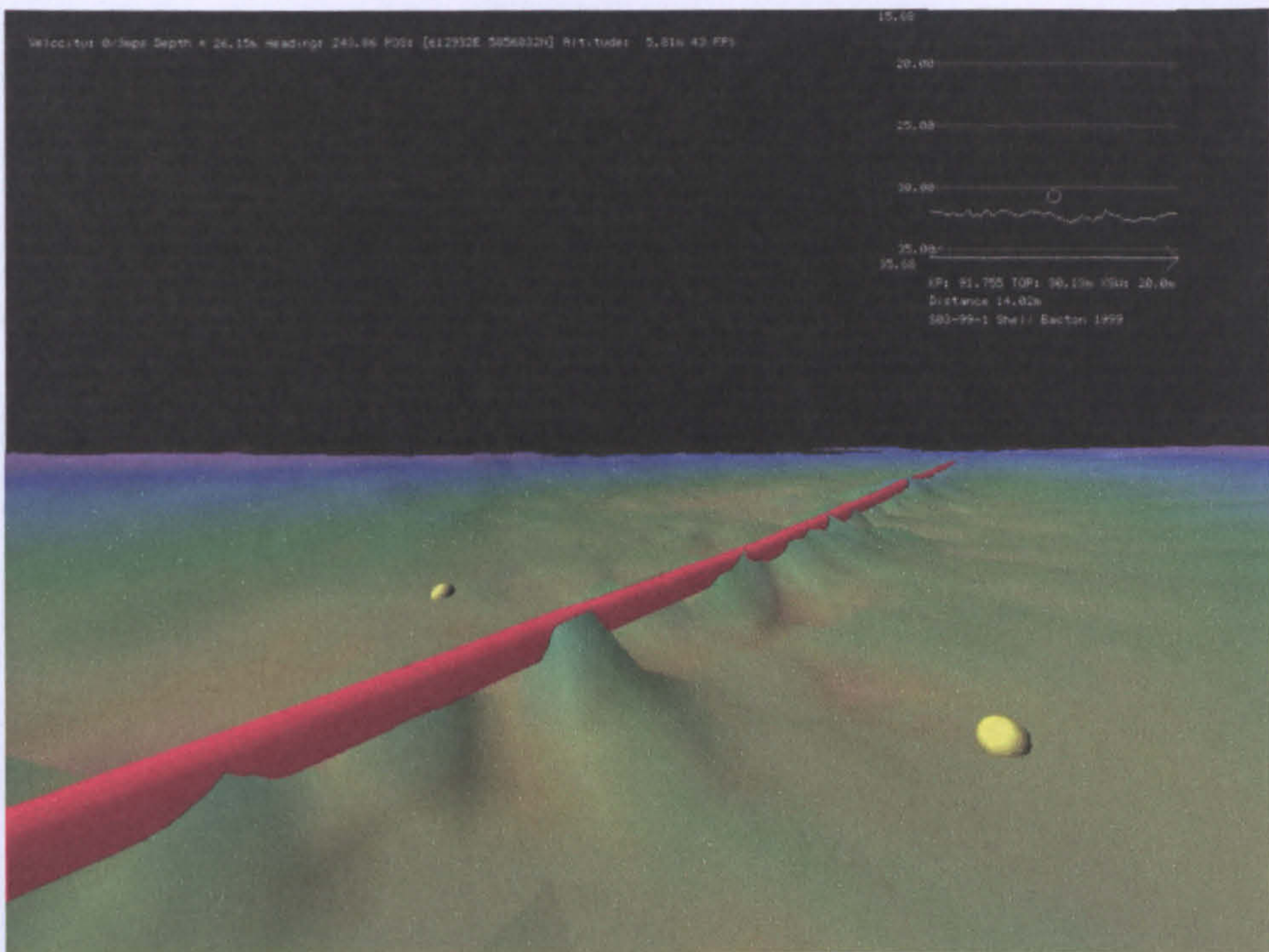

Figure 8.8: Investigating pipeline exposure points

WFM was augmented to use 'hotlinks' that permit external data for example a SBP graphic to be viewed when the user clicks on the link. These hotlinks can be associated with any object stored within the RBS and are identifiable to the user through the use of spinning 3D icons, flashing colours or flags. When the user clicks on a hotlink object with the mouse, the associated hotlink action is performed. For example, a section of pipeline at KP 2.4 has been significantly damaged and is in need of repair. An ROV has obtained video footage of the damaged section and the video is integrated into WFM. A video marker hotlink at KP 2.4 on the pipe informs the viewer that there is some ROV video footage associated with that section of pipeline. When the user clicks on the spinning object, the recorded ROV video footage is displayed on the screen.

Inclusion of Virtual Objects into the Sonar Computer Generated Model

The previous section has described the computer visualization of real objects that exist on the seafloor. It is also possible to augment the display with objects that do not exist providing the user with a powerful 'what if?' scenario. For example, Figure 8.9 shows real

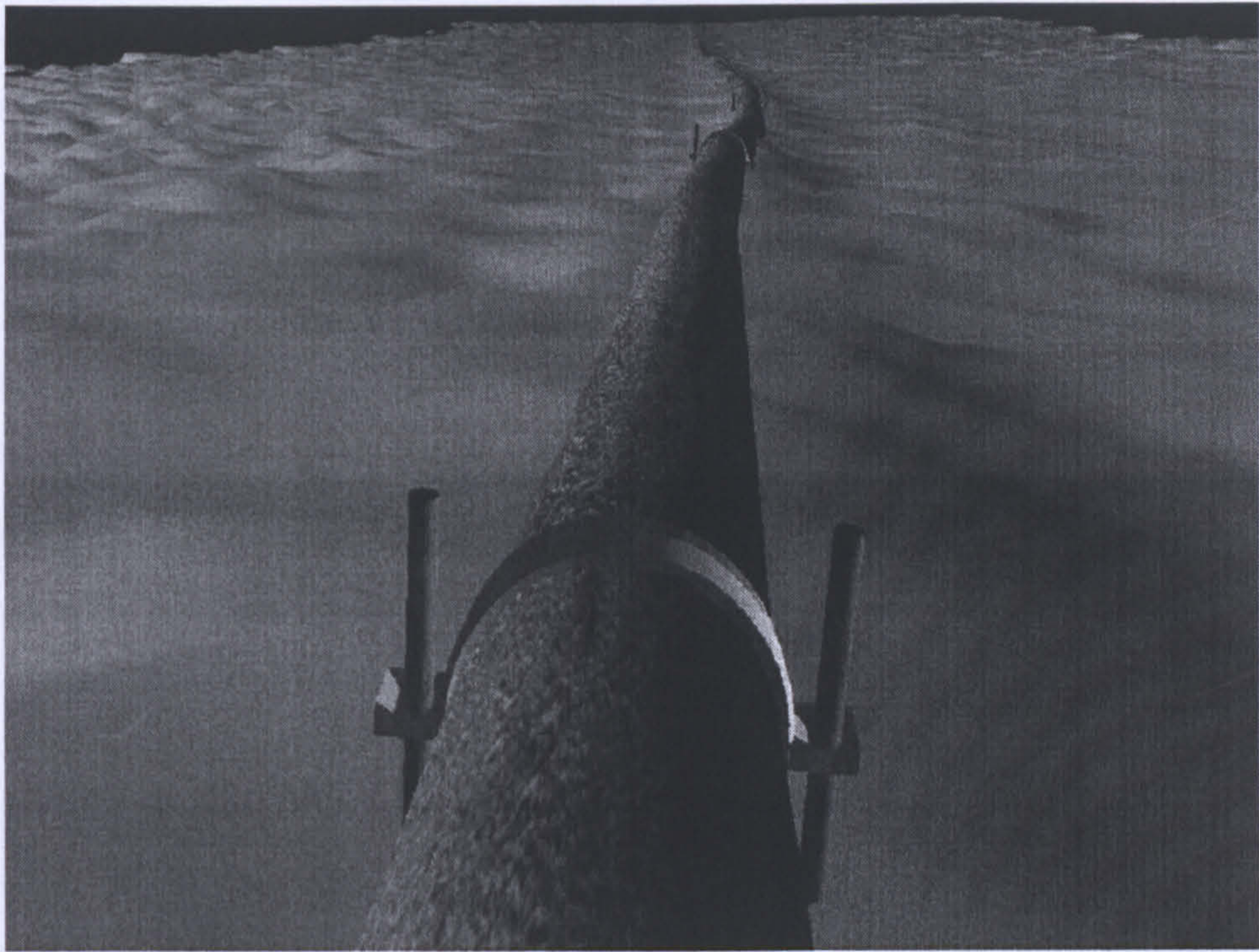

Figure 8.9: Real pipeline, real seabed, virtual screwed anchor

pipeline and seabed data gathered from Easington off the East coast of England for British Petroleum Ltd. The display has been augmented by adding a virtual screwed anchor to secure a section of freespanning pipeline to the seabed. This graphical evidence helped convince environmentalists that the pipeline restoration devices were not as obtrusive to the underwater environment as originally thought (Chapman, Wills, Stevens & Brookes 1999*b*). British Petroleum Ltd. also used WFM to better understand exactly how various methods of pipeline restoration would appear over a section of pipeline. For example, rock dumping, concrete mattresses and anchor points (shown in Figure 8.9).

8.4.3 Model Validation

When under-water pipelines were initially visualized in this interactive 3D bathymetric graphical format, it was noted that a number of clients were sceptical of the accuracy of the computer generated models. This primarily resulted from the change in data presentation: from industry standard tangible under-water reporting such as paper side scan output (Figure 8.2) or raw ROV video footage (Figure 2.6.2) to 100% computer visualization of the

8.4 Post-survey Pipeline Visualization

survey data (Figure 8.9). To validate the pipeline visualization results, a 'truthing video' was produced containing pipeline footage captured using an ROV video camera. The video footage was then directly correlated with the Seabed Visualization System's bathymetric sonar flyover. Figure 8.10 shows a frame of animation from the pipeline flyover truthing video. The bottom three views show the port, center, and starboard camera views from an ROV flying directly over the pipeline. The top three views show the corresponding computer-generated views directly correlated to the three ROV camera views. If the pipeline becomes buried, the video and computer flyover displays become redundant. Consequently, to visualize the pipe's depth, a cross-sectional display is shown in the top center of Figure 8.10. The system coloured the pipe in the cross-section according to its category: yellow for exposed pipes, green for buried pipes, and red for free-spanning pipes. The truthing video shows a direct correlation between computer visualization of the sonar data and the ROV video footage: exposed sections of pipe are perfectly synchronized in all views. This method also highlights the effectiveness of the computer-generated pipeline visualization. For example, the pipeline in the computer visualization looks much clearer than the ROV video view because it is unaffected by poor visibility. The coloured texturing of the seabed also gives a better indication of changes in seabed topography, such as the scouring effect caused by exposed pipes.

8.4.4 Post-survey WFM Architecture

This section considers the required changes to the WFM architecture in order to accommodate the discussions in this chapter.

The WFMPipe map module is responsible for importing the previously described pipe information file (PIF) and converting it to 3D geometry for rendering (stored within the RBS). The module uses the transformation matrices described above in Appendix A for the 3D calculations. Cross-section data can be handled by the WFMPipe module with terrain enquiries being handled through the original terrain DTM or via the 3D terrain model.

WFMView has been extended to calculate the intersection of the mouse position against objects rendered in the scene. If the closest intersected object contains a hotlink, the relevant information (generally a filename), will be sent to the new WFMHotlink mapping module. WFMHotlink decides how the hotlink should be executed, in most instances, the hotlink

8.5 Real-time Pipeline Visualization

will refer to an animation such as ROV video-footage which will be in an AVI/MPEG format. The file's extension, for example, *damagedPipeKP2 - 45To2 - 95.avi* is sufficient to determine the file type. Animations, sound files and graphics files are processed by the new render object WFMMultimedia which was developed using ActiveX multimedia programming tools. Hotlinks may also include Internet pages that can be loaded into web Browsers such as Netscape (Netscape 2002) or Microsoft's Internet Explorer (Microsoft 2002).

Observers can now interface directly with numerous data types related to the pipeline survey from a single visualization environment. The user may for example access:

- Bathymetric sonar data displayed in 3D, shaded and colour coded for depth.
- Accurate pipeline modelling and positioning gathered from the SVS sonar system.
- Associated damaged pipeline video footage gathered from an ROV (activated from hotlinks attached to the relevant sections of modelled pipeline).
- Seismic sub-bottom-profile imaging data gathered from a SBP.

This new synergy obtained by combining multiple data sources and types provide the user with better interpretative and decision making tools. The 3D interactive method for visualizing pipeline data in this digital format is preferred to hard copy traditional paper charts.

8.5 Real-time Pipeline Visualization

Section 8.4 described a post-survey pipeline visualization that permitted the user to interface to large amounts of collected data directly through a single WFM interface. This section describes the development and implementation of a real-time marine visualization system. Real-time marine visualization systems are defined within this thesis as systems that provide instant graphical interpretation of multiple data streams in order that the user can gain an immediate comprehension of a marine environment at the precise moment the data streams were captured. For example, if the user makes real external changes to the marine environment, for example slewing a vessel 90 degrees, then any 3D visualization of the environment should also slew the computer abstraction of the vessel by 90 degrees.

8.5 Real-time Pipeline Visualization

8.5.1 The Zeebrugge Pipelay Project

In 1998, SRD were commissioned to work alongside a dredging company to provide a sonar survey of a section of exposed pipeline off the coast of Zeebrugge, Belgium. The objective of the operation was to reduce the stress load on the pipe by dredging the seabed either side of the exposure, consequently lowering the pipeline to the seafloor. The WFM system was extended to provide a real-time high-resolution model of the dredging process, providing real-time visualization of the seabed, underwater pipeline, dredging vessel and dredge-head. The crew of the dredging vessel would normally rely on simple echo sounders to manoeuvre their vessel and to position the dredge-head in the correct location. The real-time WFM visualization system provided the captain and crew of the vessel with a more intuitive natural visualization of all the data, facilitating the dredging process including vessel and dredge-head positioning.

Initially, a 3D model of the dredging vessel was created prior to the dredging survey using the vessel's technical drawings and 3D Studio Max (Iconetics 2002). The dredge-head and arm were modelled as separate objects so they could be manipulated independently from the vessel at run-time. The 3D Studio models were then imported into the WFM database for on-line visualization. Figure 8.12 shows a snapshot from the real-time display including all the model components: dredging vessel and dredge-head, the 200m strip of seabed to be dredged, the exposed section of pipeline and the water level (viewable on the vessel's hull). Points *A* and *B* represent the extremities of the dredging survey and point *C* highlights the dredge-head position above the pipe. The different seabed colours represent changes in seabed depth.

Figure 8.13 describes the WFM transition and data-flow for real-time dredging visualization. Initially, the crew of the dredging vessel would start surveying from point *A* to *B* (shown in Figure 8.12) using SRD's SVS sonar system. After approximately 15 minutes, the dredging vessel would reach point *B* and the digital terrain maps (DTMs) and pipe information files would be created from the raw sonar data and loaded into the WFM system. This DTM conversion and import process took less than 20 seconds and did not hinder the dredging process in any way.

After surveying the seabed, the vessel would dredge the seabed alongside the pipeline.

8.5 Real-time Pipeline Visualization

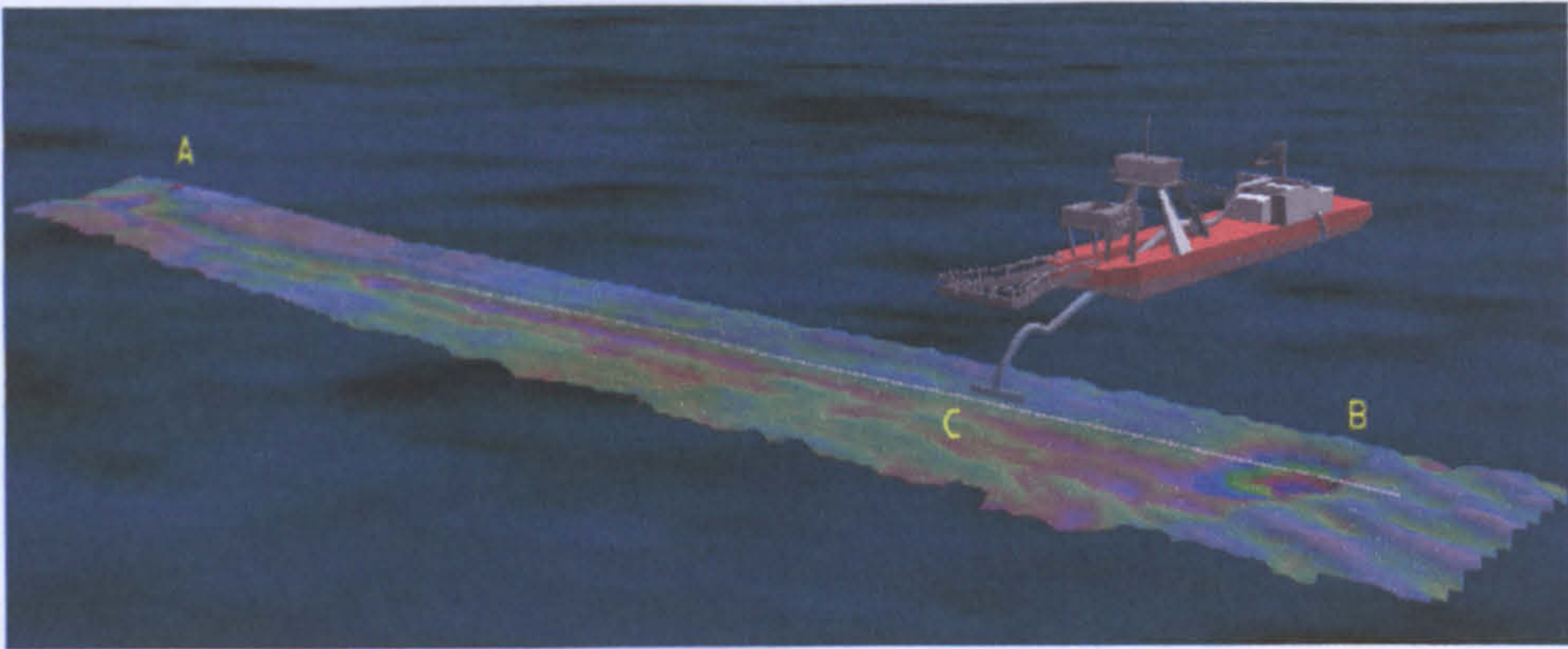

Figure 8.12: Real-time pipeline visualization

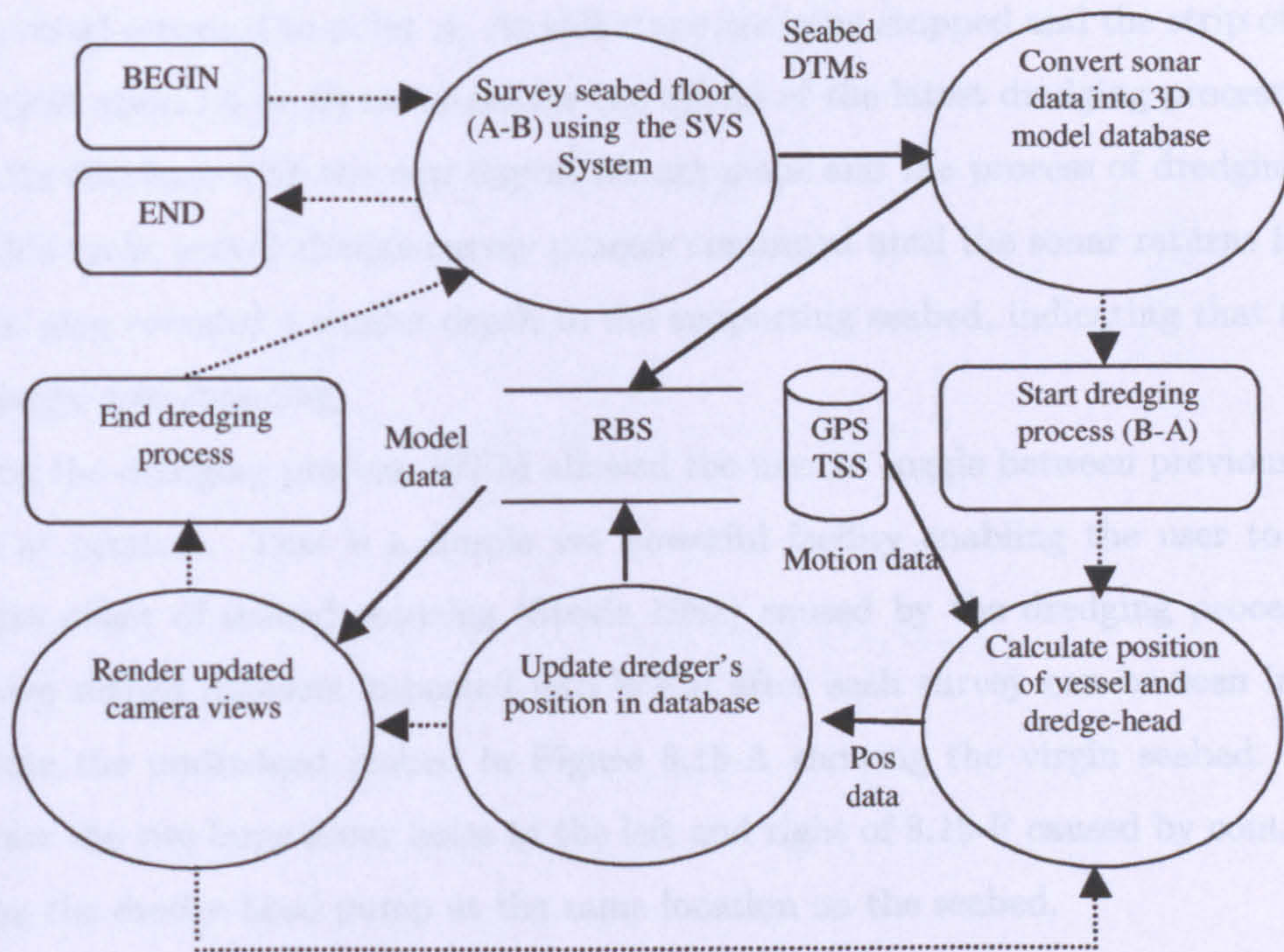

Figure 8.13: State transition / data flow

8.5 Real-time Pipeline Visualization

The real-time visualization allowed the captain to see the exact position and orientation of his vessel and dredge-head and their corresponding relationship to the seabed and pipeline. The crew of the dredging vessel used this real-time viewing environment provided by WFM to manoeuvre the vessel and position the dredge-head. The WFM display also provided the captain with numerical information such as distance under keel (altitude), depth of dredge-head and the Eastings and Northings position of his vessel.

The real-time positioning of the dredging vessel and dredge-head is achieved through a network link to SVS which in turn was linked to GPS navigation and motion sensors. A serial string consisting of a time stamp and the vessel's Easting, Northing, draft, heading (yaw), pitch, roll, dredge-head position (identified as an offset from the centre of the vessel) was captured by WFM and used for dynamic positioning.

The WFM RBS database was updated with the new dredging positional data approximately three times per second. The RBS was the main input to the rendering module that provided the real-time display. This display was updated continuously at 22Hz as the dredging vessel returned to point *A*. At this stage dredging stopped and the strip of seabed was surveyed again (*A* to *B*) to determine the effects of the latest dredging process. WFM updated its database with the new digital terrain maps and the process of dredging began again. This cyclic survey-dredge-survey process continued until the sonar returns from the top of the pipe revealed a similar depth to the supporting seabed, indicating that the pipe was no longer free-spanning.

During the dredging process, WFM allowed the user to toggle between previous seabed datasets at runtime. This is a simple yet powerful facility enabling the user to see the cumulative effect of seabed scouring (Stride 1982) caused by the dredging process. The consecutive seabed datasets imported into WFM after each survey can be seen in Figure 8.15. Note the undredged seabed in Figure 8.15-A showing the virgin seabed. Also of interest are the two large scour holes to the left and right of 8.15-F caused by continuously activating the dredge-head pump at the same location on the seabed.

8.5.2 Real-time Architecture

To support the realtime pipeline visualization described in this chapter, WFM's architecture was augmented to include a network link to receive the 6D positional information from

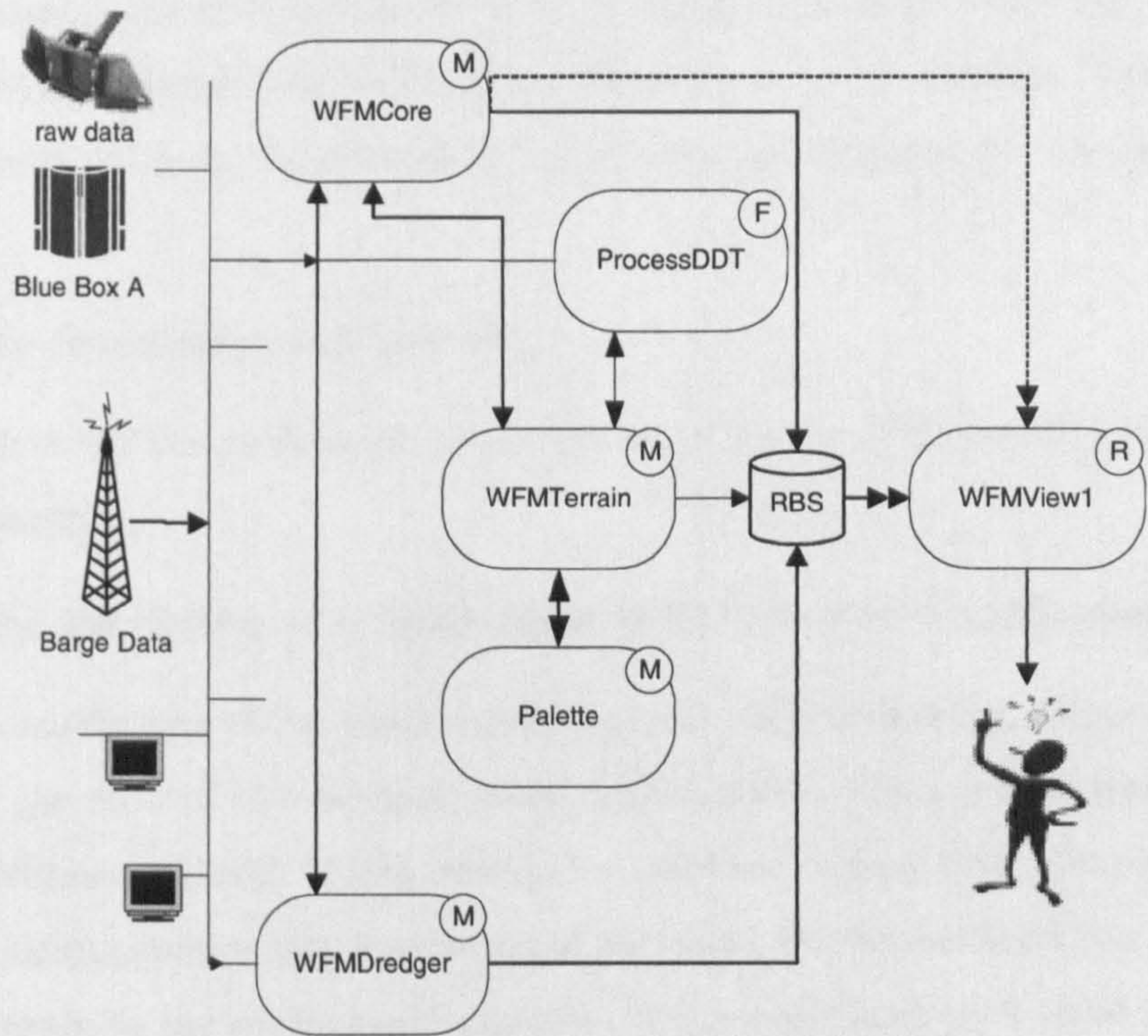

Figure 8.14: Real-time WFM architecture

8.5 Real-time Pipeline Visualization

the barge (Easting, Northing, depth, pitch, roll and yaw) and the state of the dredger's suction arm to the WFM system. The WFMDredger mapping module is responsible for processing this data and updating the WFM model of the vessel within the RBS. Figure 8.14 shows the module architecture for the real-time dredging visualization (note that to improve readability in the current and subsequent architecture diagrams, the author has removed control lines linking the user to each of the modules).

The WFMDredger module does not require a pre-filter module because the filter process of calculating the vessel's position such as HPR is calculated internally within the motion sensor on the vessel which sends out an RS232 serial string onto the network. This data may be captured by WFM from the network or fed directly into the machine via the serial port.

8.5.3 Real-time Summary and Results

This section considers WFM's performance based on the real-time objective defined at the beginning of this chapter.

To Investigate the Feasibility of a 'Real-time' WFM Marine Visualization

WFM's real-time visualization of the pipeline dredging process in Zeebrugge, Belgium (Section 8.5) provided the crew of the dredging vessel with a natural data visualization environment of their offshore activity. WFM provided a real-time display that permitted the captain to see the exact position and orientation of his vessel and dredge-head and its corresponding relationship to the seafloor and pipeline. This visualization tool could be used by the captain to manoeuvre his vessel and position the dredge-head in real-time. The experiments reported in this chapter have proven that it is feasible to provide natural 3D computer visualizations of an offshore activity.

The modular WFM architecture has been well suited to the demands of real-time visualization of continuous data streams and the architecture plan has proved that complex visualization pipelines are not required for effective real-time visualizations.

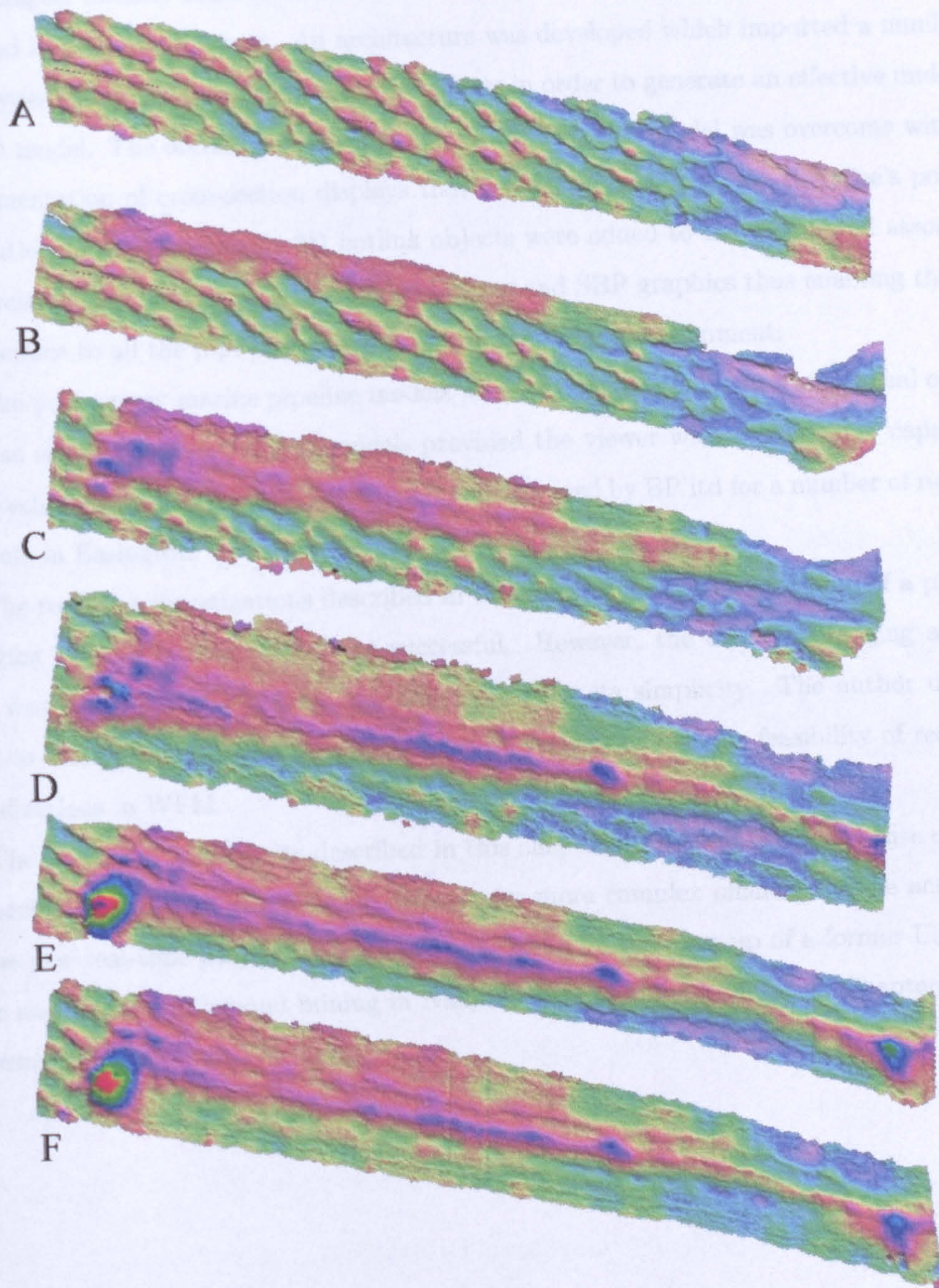

Figure 8.15: Iterative Dredging Process

8.6 Summary

This chapter initially considered how underwater pipeline and associated data could be visualized in a 3D environment. An architecture was developed which imported a number of data types, from bathymetric data to SBP points in order to generate an effective underwater 3D model. The occlusion of buried pipelines within this model was overcome with the implementation of cross-section displays that enable the viewer to see the pipe's position in relationship to the seabed. 3D hotlink objects were added to the model and associated with related data sets such as ROV video footage and SBP graphics thus enabling the user to interface to all the pipeline survey data in one succinct environment.

The post survey marine pipeline models were augmented to incorporate virtual objects such as screwed anchors. These models provided the viewer with a 'what if?' capability. This technique proved to be very successful and was used by BP ltd for a number of research projects in Easington.

The real-time investigations described in this chapter for the visualization of a pipeline dredging process have proved to be successful. However, the offshore dredging activity that was visualized in real-time was selected due to its simplicity. The author did not want to attempt to visualize a complex offshore activity to test the feasibility of real-time visualizations in WFM.

The successful field results described in this chapter have justified the expense of more research into real-time visualization displays for more complex offshore marine activities. These new real-time projects: real-time visualization of the clear-up of a former US Naval Base and real-time diamond mining in Namibia are described in detail in Chapters 9 and 10 respectively.

Chapter 9

Real-time Debris Clear-up Visualization

The case study described in Chapter 8 successfully demonstrated that WFM could facilitate offshore operations by providing a real-time 3D graphical display of a pipeline dredging process. This proof of concept dredging activity modelled only a small number of moving objects such as the barge and dredge arm.

This chapter builds upon the positive real-time results of the previous case study by considering if increasingly complex offshore activities can be modelled effectively in 3D. This chapter describes a complex offshore activity that is the clear-up of a former U.S. Naval Base. The aim of this chapter therefore is an investigation into the feasibility of using 3D computer graphics to facilitate comprehension of complex offshore activities. The case study evaluation map for this chapter can be seen in Figure 9.1.

The objectives of this case study are threefold:

1. To consider the real-time modelling of machinery used in a complex debris clear-up operation. For example, real-time modelling of cranes etc.
2. To consider the real-time modelling of underwater vehicles such as ROVs.
3. The psychological study of offshore staff interfacing to a 3D graphical visualization of complex offshore procedures.

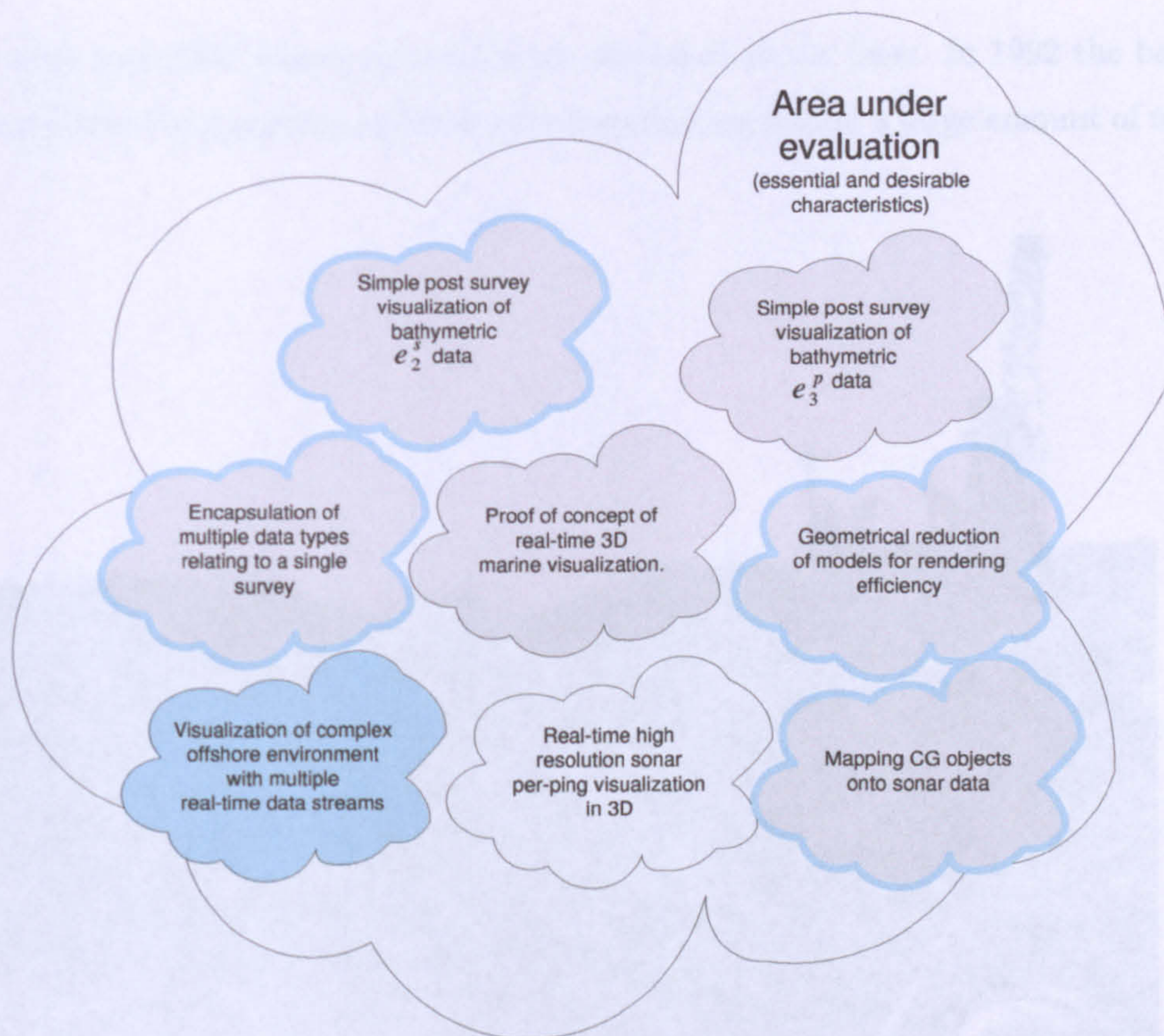

Figure 9.1: Case study evaluation map

9.1 Introduction

This case study describes the effective real-time visualization of the clear-up operation of a former U.S. nuclear submarine base, located in Holy Loch, Scotland. WFM was used to provide an accurate real-time visualization of a large number of varying parameters such as remotely operated vehicles, cranes, barges, grabs, magnets, and detailed seabed topography. The system has improved the field staffs' spatial and temporal awareness of the underwater environment and facilitated decision-making within the complex offshore working environment.

Holy Loch lies approximately 50km due West of Glasgow and is 3.9km long and 1km wide. It has been used for military purposes by the British and the US since the First World War. In 1945, the US military returned to the loch to act as peace keepers to the NATO alliance. The US Navy operated a submarine base (Figure 9.2) in the loch for over

9.2 The Clear-up Process

30 years with over 1500 American servicemen stationed at the base. In 1992 the base was finally closed and the American military withdrew leaving behind a large amount of military debris.



Figure 9.2: Photograph of original base

Before the base could be returned to the Clyde Port Authority, the loch needed to be carefully cleared of all debris. In 1996, Sonar Research and Development Ltd. were contracted by the mooring and salvage organization of the Ministry of Defence to assist in the clear-up operation of the loch.

9.2 The Clear-up Process

SRD initially surveyed Holy Loch in 1996 using their SVS sonar system. The resulting high-resolution bathymetric data geographically highlighted the main debris areas. Most of the debris was located directly under the original floating docks. Figure 9.3 shows a depth coloured bathymetric plot from the sonar survey showing the seabed that lay directly under the original floating Naval Base. Note the scour marks (Stride 1982) in the loch floor

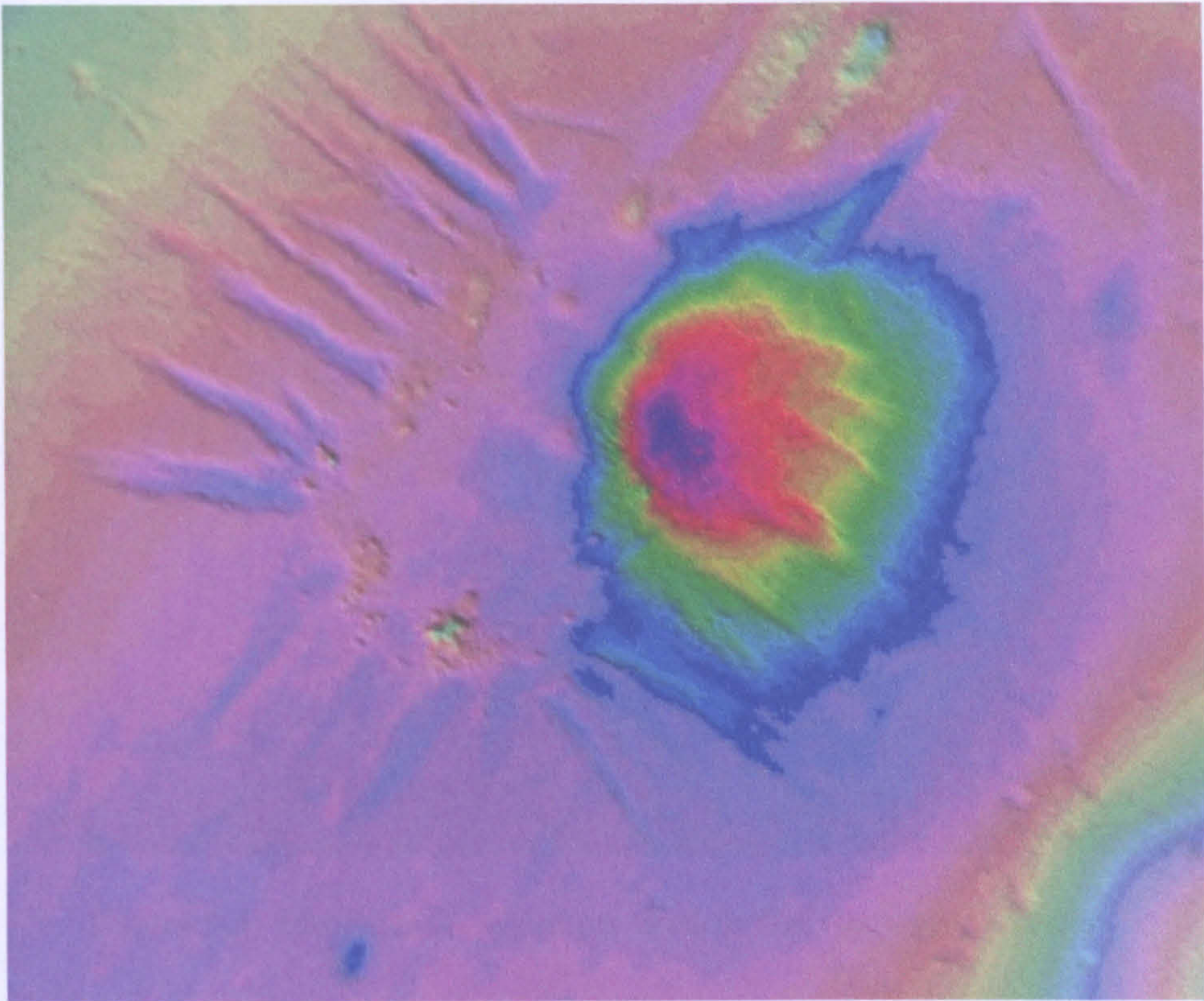

Figure 9.3: Depth coloured bathymetric plot

(left of the image) caused by the original heavy anchor chains that secured the docks. The deep circular hole in the centre of the image was originally found to be one of the deepest locations in the loch and consequently used as the main position for the floating docks.

Figure 9.4 shows an arial photograph of the barge used for the clear-up operation. The barge is approximately 50m by 15m wide. Note the cranes at the front of the vessel and the operational control cabins to the rear. The barge is manoeuvred via four long anchor wires running from each corner of the vessel to secure anchors on the loch floor. By slackening or tightening the anchor wires, the barge can be positioned to within metre accuracy over a target area.

The barge used three over-the-side sub-surface transducer arrays and associated motion compensators. A real-time kinematic GPS system was mounted at the top of the crane's jib for positioning purposes.



Figure 9.4: Photograph of barges used in the clear-up procedure

9.2.1 Clear-up Procedure

The area for debris clearance in Holy Loch has been split into a number of 25m^2 blocks. Each block is broken down into four 12.5m^2 areas (identified A-D). These blocks are composed of 9×9 individual lifting zones (approx 1.3m^2 each). Figure 9.5 describes a simplified model of the clearance operation.

Initially, a working block is pre-surveyed using the SVS subsurface transducer array. This survey will identify the exact location of any debris within the 81 lifting zones. After the sonar pre-survey, the barge is positioned for grabbing and magnetting. Initially, the grab is fitted to the crane's block and lifting begins. The grab is lowered to the seabed, closed and raised 3m off the loch floor. If the crane's load-cell suggests that there is debris on the grab, the grab will be raised back to the surface. The grab is then continually lowered to the seabed over a particular drop zone until no more debris is recovered. All debris collected from the main crane is carefully lowered onto the wash-down deck and an immediate visual inspection takes place. Extreme care was taken when lowering debris to the wash-down deck and any suspicious or potentially explosive material found was detonated away from

9.2 The Clear-up Process

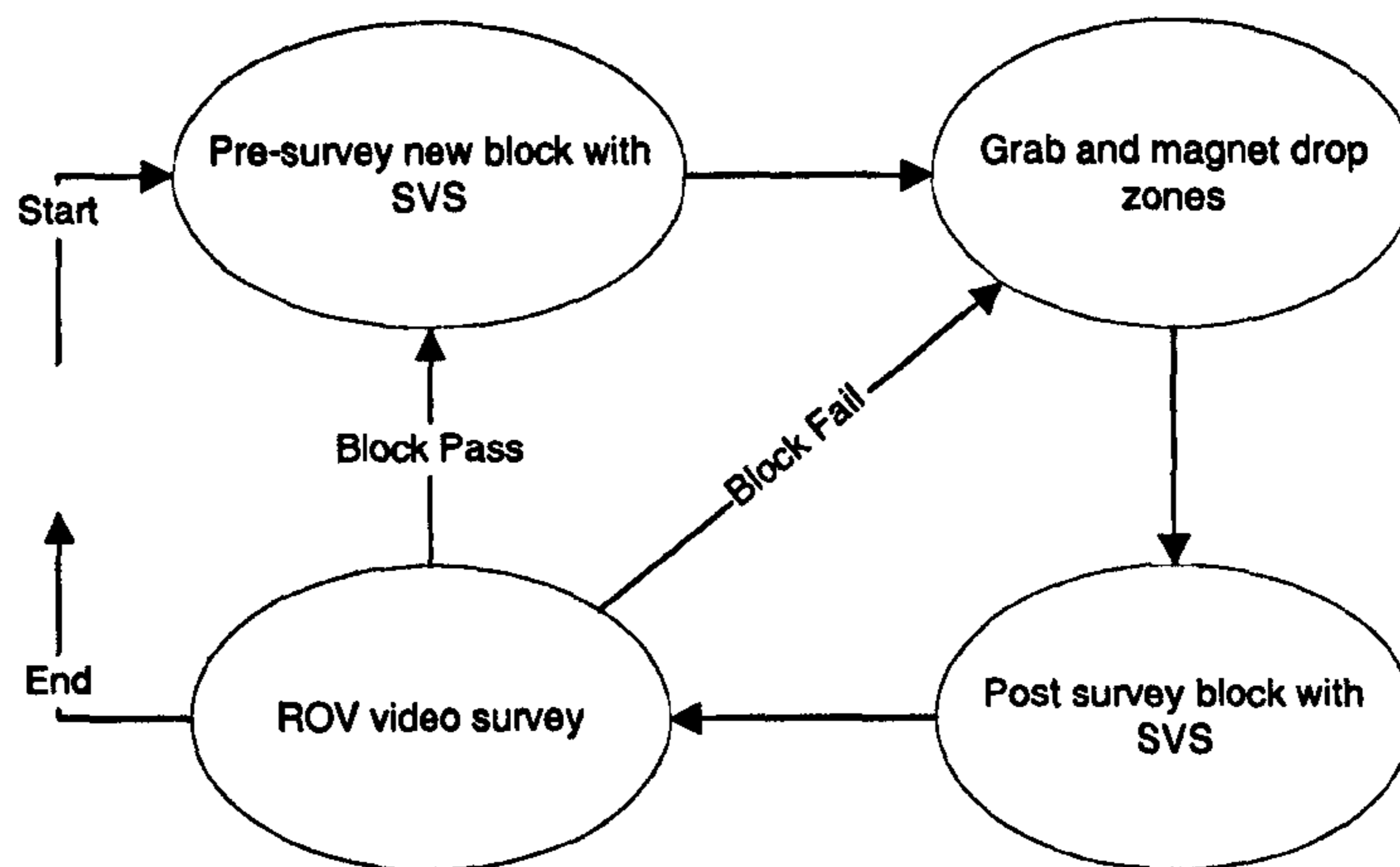

Figure 9.5: Debris clearance procedure

the salvage barge by bomb disposal experts.

The wash-down crew then clean the silt and mud off the debris using two high-powered water cannons. The debris is subsequently checked for any abnormal levels of radiation to ensure that the gamma radiation does not surpass the background level. The debris is then broken into sections using hydraulic cutters and lifted into skips using a secondary grab. A computer database keeps accurate records of every single lift such as wet weight, dry weight and debris classification. The skips are finally placed into an adjacent barge for later removal from the site and re-cycling.

When a drop zone is clear, the crane driver moves the grab onto the next adjacent drop zone. When all 81 zones have been cleared, the grab is replaced by a large electro-magnet and the clearance process for all 81 zones is repeated. The magnet collects smaller metallic debris from the loch bed that might slip through the grab. For example gas bottles, spanners and shells.

After magnetting, a post-survey of the area is performed using the barge-mounted transducers. A Phantom Mark II ROV (OPL 1999) (Figure 2.2) is then deployed from the back of the barge to perform a visual inspection of the block. After the post survey, the ROV will fly over the block in nine runs providing video data of the entire block. The precise position of the ROV is known at all times so any debris located can be geographically tagged. After the ROV has finished the video survey, the block will either pass or fail. A failed block will need to be re-magnetted or re-grabbed (depending on the nature of the debris remaining)

9.3 Implementation

in the problem areas identified by the ROV video survey. If the block passes, the barge will be moved to the next block (A-D) and the entire process: pre-survey, grab/magnet, post-survey, ROV survey, is repeated.

9.2.2 Complexity of Operations

Section 9.2.1 has provided a simplified model of the clearance procedure. In reality, the process is more streamlined and not as linear as the model described in Figure 9.5. For example, while the crane is grabbing a particular block, the ROV will be flying over a previously grabbed block and performing a video survey.

The aim of this case study was to consider WFM as a real-time visualization tool for complex offshore activities. Analysis of the offshore scenario described in this case study is sufficiently complex for integration and analysis within WFM in order to meet the initial aim of this chapter. At a single moment in time, a number of activities are taking place: the ROV flying over the seabed, the movement of the barge, the movement of the crane arm, the position of the grab and magnet and the collection of bathymetric terrain data collected from the sonar surveys.

With the existing system it was difficult to quickly conceptualise the location of moving objects in relation to other objects. For example, it is imperative that the ROV pilot knows the ROV's position in relation to the five tonne electro-magnet under the water.

9.3 Implementation

To build an effective real-time model of operations, a large amount of data was required from a number of different sources. This section describes the data required and explains how these components were visualized within WFM.

Figure 9.6 shows a snapshot from WFM's real-time visualization of the clear-up operation. The image shows the barge in its actual position including a correctly modelled and positioned crane preparing to drop some debris onto the wash-down deck. The 3D models used in the visualization were created using Kinetix's 3DStudio Max (Lee 2001) from detailed engineering drawings and then imported into WFM and modified for functionality and real-time visualization. Rolling clouds and mountains were included to make the virtual environment as realistic as possible. It could be argued that the inclusion of such elements

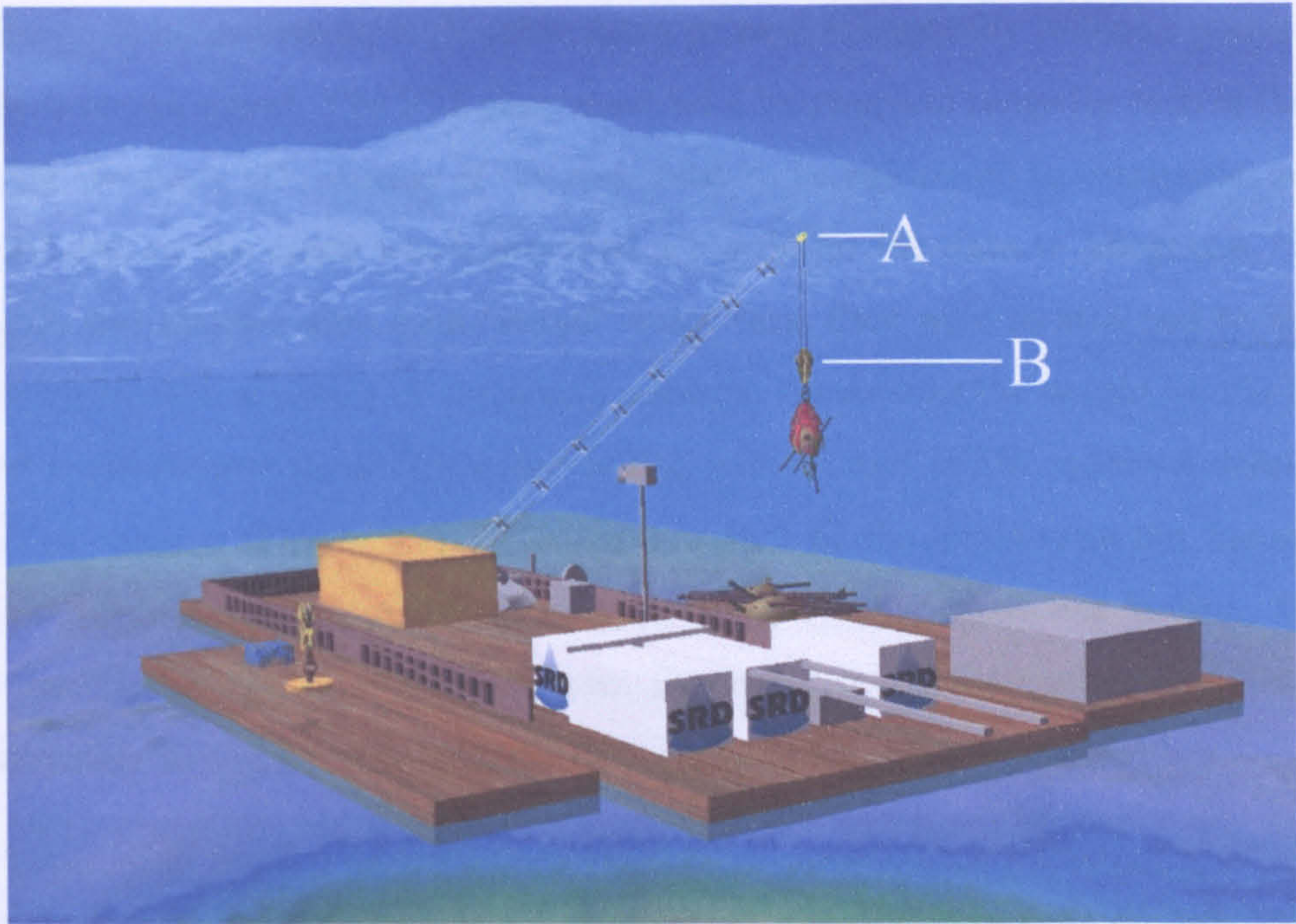

Figure 9.6: WFM real-time display of clear up operations

would not add to the interpretative quality of the visualization. However, in all the case studies, elements of realism were always well-received by the offshore engineers and staff using the system.

The barge's location was calculated using real-time kinematic (RTK) satellite tracking that provides centimetre positional accuracy. The squat and draft of the barge was calculated using a tide monitor located at the front of the vessel. Motion sensors provided rotational information: heave, pitch and roll. Yaw (heading) was available from the vessel's compass.

The physical dimensions of the main crane were known including its offset from the centre of the vessel. A GPS receiver on the tip of the crane jib (Figure 9.6-A) permitted the crane's heading and pitch to be calculated¹.

The underwater positioning of the grab and magnet were calculated by placing a responder onto the crane block (9.6-B). As the crane block travels towards the loch floor, the responder sends out a signal at a known frequency. Two transducer arrays, positioned

¹The heading and pitch of the crane arm can be calculated because the position of the crane's base was known as an offset from the centre of the vessel (known via the RTK). Since the length of the crane jib was known, the required yaw and pitch angles of the crane jib could be calculated.

9.3 Implementation

on the barge at 90 degrees to each other listen in two orthogonally different planes for the responder's return signal. The SVS then provided a bearing and range for each of the planes permitting the exact 3D position of the responder to be calculated to centimeter accuracy.

A load-cell on the crane winch provided a metric for lift data in kilograms. The five tonne grab and magnet were each 'zeroed' every time they were re-attached to the crane block improving the accuracy of the lifting sessions. As soon as the weight on the load-cell exceeded a pre-defined threshold, a debris flag was set and WFM rendered debris under the grab or magnet (Figure 9.7). The exact nature of the debris was not known so an exact visualization was impossible as only the weight being lifted was known. However, to give some indication of the weight from the load-cell, the debris's volume was scaled proportionately to the amount being lifted (assuming homogenous debris).



Figure 9.7: Grab breaking water level with debris flag set

The large grab has five hydraulic arms (Figure 9.7) and stands approximately 2m tall with a span of 1.5m². The grab can be open, closed or moving between states. The pressure applied to the grab to open and close the arms is measured using pressure sensors and sent to WFM which permitted the visualization system to open and close the grab in real-time.

9.4 WFM Architecture

The five tonne electro-magnet has a diameter of 1.5m and has two states: on and off. The amount of current passing through the magnet is also captured by WFM so that the magnet can be coloured depending on its state: yellow for off, the magnet's actual colour, and red for active or live.

The data read from the SVS sonar transducers fixed on the barge was converted into digital terrain maps upon request and imported automatically into the WFM model. The terrain was colour texture mapped according to depth. After a sonar survey, WFM received a network command to import the new terrain into the model. To provide rendering efficiency, WFM used multiple levels of detail (introduced to the reader in Section 6.5.3) for the terrain depending on the viewer's position. Terrain reduction algorithms were not used to reduce the complexity of the terrain datasets due to time constraints. Simplified datasets were created by under-sampling the high-resolution DTMs.

The Phantom ROV was modified to include motion sensors, responders and a specially designed miniature SVS developed at SRD. The position of the ROV is calculated in the same way as the crane's block and detected using a secondary SVS barge mounted transducer system.

All the above data was streamed into the WFM visualization over a 100 Base-T network. WFM was implemented on a Pentium III 600MHz PC using nVidia II graphics technology.

9.4 WFM Architecture

Figure 9.8 describes the WFM architecture used for the implementation of the debris clear-up operation. For this operation, two BlueBox sonar systems were required. The first system, BlueBox A, was used specifically for gathering seabed terrain topography and tracking and calculating the position of the transponder on the crane block. The second BlueBox system, BlueBox B was used solely for the ROV tracking.

The architecture used exactly the same processes to produce seabed terrain as described in previous case studies. ProcessDDT, WFMTerrain and WFMPalette consequently need no further explanation. The new elements within the architecture are described below.

The architecture contains two WFMModel modules for positioning the barge and the ROV. In both instances, the modules receive 6D positional input over the network at about

9.4 WFM Architecture

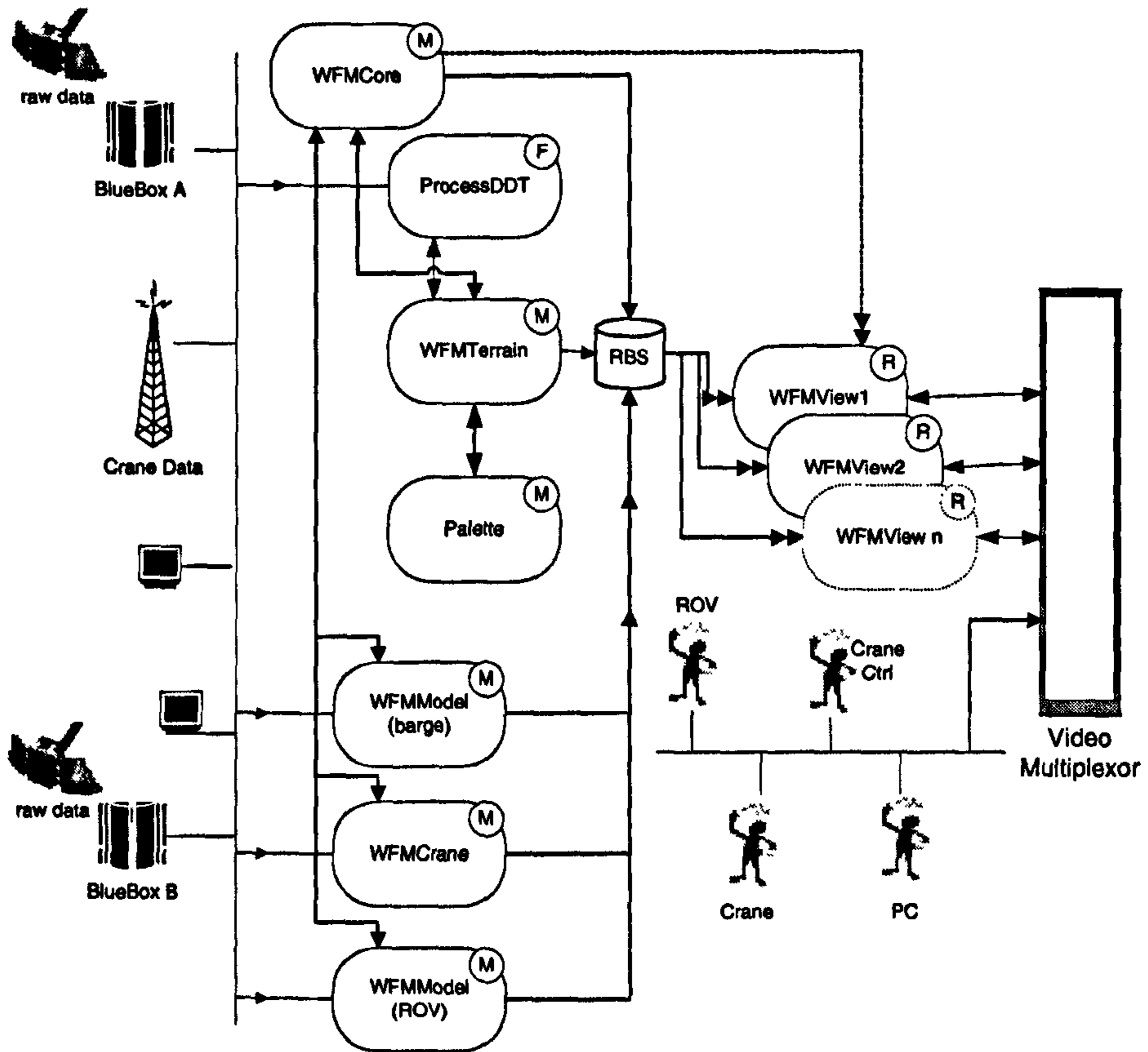

Figure 9.8: WFM Debris clear-up architecture

3Hz relating to the barge and ROV position. Specifically, Easting, Northing, depth, yaw, pitch and roll. The depth value for the barge was calculated from tide information and vessel draft. The ROV depth was calculated by the dedicated BlueBlox B. Upon receiving positional information, the WFMModels updated the associated model positions within the RBS.

The WFMCrane map module is responsible for changing the geometry within the RBS database to reflect real-time calculated crane movements. A dedicated module was required because the object was not classified as a 'simple object' (previously defined in Section 7.4.2) and could not therefore be controlled by a WFMModel object. The crane movements included: pitch and yaw of the jib arm, lowering and raising of the crane block, opening and closing of the crane grab, activating and de-activating the crane electro-magnet and rendering the debris flag under the grab or magnet.

9.5 Problems Encountered

Parameters such as the measured load-cell and the sampled electrical current flowing through the electro-magnet do not need filter modules within the WFM architecture. This is because the filter processes are performed internally within the relevant hardware. For example, the physical load-cell mounted on the crane jib contains hardware that converts the analogue stresses into an RS232 serial string that is transmitted over the ship's network. Consequently, this data can be fed directly into a map module such as WFMCrane.

The architecture in Figure 9.8 also contains a number of WFMView render modules. These modules each render a different view of the clear-up operation held within the RBS. Views may include an orbiting aerial camera of the barge in operation, or an underwater close-up of the ROV or crane grab. All these views are fed into a multiplexor so they can be channelled around the control cabins on the barge allowing various users to select their own work related view.

9.5 Problems Encountered

The majority of this visualization system was developed at Sonar Research and Development's headquarters in Beverley, England by simulating operations from captured data recorded in Holy Loch. Actual implementation of the system on the barge highlighted a number of unforeseen problems.

Debris was originally flagged based on the value returned from the crane's load-cell. However the magnet had a greater surface area than the grab and consequently registered significantly more drag underwater. As a result, more energy was required to pull the magnet through the water column than the grab. Consequently, different load-cell debris thresholds were required for the grab and the magnet.

Another unforeseen problem was the discovery that different crane drivers had very different styles of working. For example, one crane driver may pull the grab through the water column faster than his workmate. This was discovered after the system had been correlated and was thought to be working. When the next work shift started (which contained a new crane driver), WFM incorrectly flagged the debris field within the visualization. Thresholds therefore needed to be specific to crane drivers. Fortunately there were only two crane drivers so this did not prove to be a problem. If a number of crane drivers were using the

9.6 Results

system, a calibration procedure could be included so that each crane driver would select their own personal 'driver parameters' during a shift changeover.

Another potential stumbling block was that the crane block's responder could not be tracked in less than 2m depth of water due to the nature of the sonar equipment. Consequently, when the crane driver lifted the grab or magnet out of the water, the crane's block depth positioning was lost. A rule was consequently introduced so that if WFM had not heard from the block's responder within the last four seconds, then the block must be out of the water. The block is then rendered at a fixed height of 6m above water level.

The heading and pitch of the crane is unaffected by the inability to track the block out of the water because the crane's positioning relies on a DGPS receiver placed on the tip of the crane jib. As a result the system can visualize the crane driver depositing the debris on the wash-down deck.

9.6 Results

This section considers WFM's performance based on the three objectives outlined at the beginning of this chapter.

9.6.1 Real-time Modelling of Machinery used in a Complex Debris Clear-up Operation

The dedicated crane module described in Section 9.4 has successfully visualized various states of crane state operability in real-time. Numerous streams of data such as load-cell weights, GPS crane tip positions, and the calculated position of the underwater responder attached to the crane block have all been filtered into the WFMCrane module (described in Section 9.4). The resulting outputs (Figures 9.6 and 9.7) have proven to be extremely accurate and popular with the offshore staff (Section 9.6.3).

During the testing and implementation of the WFMCrane module, a live data stream containing crane data was imported into the WFM system for the first time. The rendered output accepted the data and animated the offshore activity in real-time. However an error was thought to have occurred as WFM's 3D crane display did not show the crane lifting material out of the water but was instead lifting an extremely heavy load directly over the control cabin (the cabin where the author was developing the system). This was

9.6 Results

immediately thought to be an error in the interpretation of the data (such as the rotation and translation maths routines) . However, upon further examination (looking out of the cabin window), it was discovered that the WFM display was in fact accurate and the crane driver was lifting fully loaded skips of U.S. debris directly over the control cabin. The cabin was immediately vacated.

9.6.2 Consider the Real-time Modelling of Underwater Vehicles

This case study has described the first instance of multiple BlueBoxes in order to provide WFM with data related to multiple objects. The use of a secondary BlueBox dedicated to locating a submerged ROV (complete with pingers) has enabled WFM to provide a richer more active real-time display. A sample real-time display of the ROV underwater can be seen in Figure 9.11. As mentioned previously, the ROV can be positioned using the generic WFMModel map module.

The ROV depicted in Figure 9.11 also includes vertical depth lines to facilitate the viewer's interpretation of the ROV's position in 3D space. This technique of vertical lines improving depth perception is a tried and tested technique and is typically applied to aircraft such as planes and helicopters (Azuma, Ill & Daily 1999). This case study has shown that the same technique works equally well with underwater vessels.

9.6.3 Psychological Study of Offshore Staff Interfacing to a 3D Graphical Visualization of Complex Offshore Procedures

WFM successfully rendered to a number of displays within the control cabins on the barge (Figures 9.9 and 9.10). Specifically, the ROV, crane, control and Party Chief cabins. The displays were multiplexed so the viewer could switch between various predefined views (such as under the barge, ROV camera viewpoint and fixed crane grab cameras). The WFM system rendered at an average of 25fps and had real-time positional updates to the RBS visual database of between .5 and 1Hz.

Very little training was required for WFM as the staff did not need to be taught how to read and interpret WFM's natural viewing environment. The visualization system was tested on five different ROV pilots and control staff, two crane drivers and two Party Chiefs.



Figure 9.9: WFM implementation in the ROV control cabin (bottom right monitor)



Figure 9.10: WFM implementation in crane control cabin (bottom right monitor)

Crane Drivers

One problem for the crane drivers was that their work can become extremely monotonous, increasing the potential for error. A typical mistake would be forgetting to sensitise the magnet on the loch floor. Supplying the crane driver with the WFM 3D view (rendering the state dependent coloured magnet) eradicated this error completely. The crane drivers also reported that they felt more comfortable knowing the whereabouts of the ROV underwater².

When working offshore, not all of the offshore staff working on a particular job may have much experience of computers and even fewer will have experience of 3D graphics displays. Their interaction with computer graphics displays can lead to some interesting observations. For example, some of the crane staff who were observing WFM's real-time display remarked that the contents of the debris were on occasions incorrect. This was an interesting observation as the author had assumed that they would know that the debris visualization was merely a visual flag to inform them that the crane was lifting 'debris' of some kind. However, from the crane driver's perspective, every time the grab had exited the water, the computer visualization had accurately matched reality (the computer visualization was merely scaling the debris based on the load-cell reading). The crane driver's 'user model' (Barfield 1993) was built on the predicate that the virtual grab does in fact provide an accurate description of reality. This assumption leads to an incorrect user model. Problems then occurred when the grab retrieved material that was visually different from the computer's visualization. The system may be working perfectly but the user will think there is a fault in the system and may return to more traditional early feedback mechanisms and therefore ignore the WFM display.

Control Cabin Staff

After WFM had been successfully implemented, it was noted that control cabin staff no longer needed to shout to the adjacent ROV cabin to confirm that the ROV was in a safe position prior to a barge move as the WFM display would always provide the ROV's position in relation to the barge.

The cabin staff also reported that WFM provided a 'welcome change' to the large amount

²No doubt worries were due to the incompatibility between large relatively inexpensive grabs with small very expensive ROVs.

9.6 Results

of graphs and sound signals emanating from the PCs within the control cabin. This positive feedback may be due to the reduced interpretative mental work required to interpret a 3D visual display compared to dials, numbers, audio and graphs. As previously stated, very little training is required for interpreting WFM's rendered images as the graphics are all based on reality (a user does not need to be taught how to interpret natural images³). Complex interfaces that reflect reality can produce user interpretive time lags which can lead to errors. This is considered in more detail in Chapter 12.

ROV Pilots

The ROV pilots were provided with a WFM 3D display which augmented their 2D ROV displays. On occasions, the silt on the loch floor would be heavily disturbed by the nearby grab lifting operations. This sediment upheaval would reduce the ROV camera visibility to zero. The WFM system was unaffected by poor visibility and continuously provided the pilots with a crystal clear 3D visualization of their ROV underwater (Figure 9.11).

Party Chief

The main benefit of WFM reported by the Party Chief (responsible for all operations offshore) was WFM's ability to provide a more complete picture of the clear-up operation in real-time and in a format that was immediately comprehended. Figure 9.11 shows a typical underwater view selected by the Party Chief that encompasses the barge, crane, grab and ROV all in their relative real-time positions.

The party chief also had the added luxury of a Microsoft SideWinder joystick to manoeuvre a virtual vessel (SRD1) to select any viewpoint or area of interest within the real-time model. This would include the ability to closely examine anomalies on the loch floor generated by the sonar data.

Stereo Displays

The implementation of a stereo display was briefly considered for particular members of staff, for example using liquid crystal shutter glasses, but was rejected because of the cramped

³With the exception of certain abstractions. For example, being taught that an activated electro-magnet is red and otherwise will be coloured yellow.

9.7 Summary

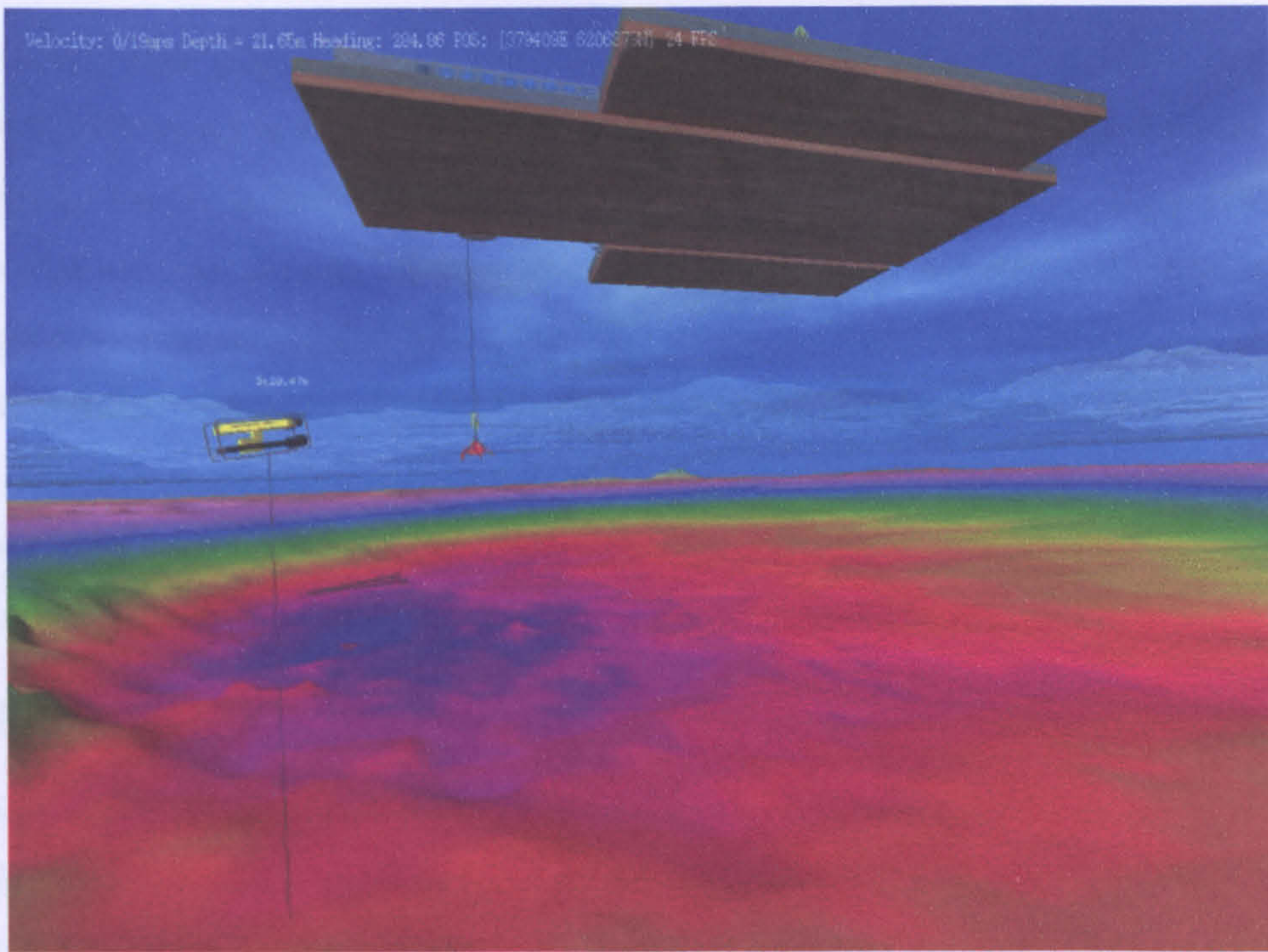

Figure 9.11: Typical Party Chief selected view

and hazardous nature of offshore working environments. Immersive marine environments are considered in more detail in Chapter 11.

9.7 Summary

This chapter has provided another real-world example of how the Whole Field Modelling System can be used to effectively visualize large amounts of data in the offshore marine environment. All parties welcomed the visualization and although the system did not replace the current software tools used for the survey, they did augment, enhance and improve operations. The primary benefit reported from WFM's visualization was a significant improvement in spatial and temporal perception of all components used in the survey. The real-time implementation of WFM offered opportunities for improved effectiveness of the clear-up operation and has provided the field staff with an improved understanding of the underwater environment reducing the potential for error, which in the offshore industry can be extremely costly, both financially and ecologically.

One interesting observation that arose from this case study was that certain visual

9.7 Summary

abstractions were misunderstood (such as the crane driver's interpretation of the WFM's debris flag described in Section 9.6.3). It is therefore imperative that offshore visualizations, however trivial, be carefully explained to those who must interpret them. Blinn (1990) once wrote that he heard a radio reporter describe Halley's comet as being really beautiful with a bright red core, surrounded by a green shell which was surrounded by a larger blue shell. In this instance, colour banding had been used to enhance the contrast of monochromatic data. The person interpreting the visualization (the radio presenter), had not been properly educated in the translation of the visualization. In this case study, the crane driver had not been properly educated regarding the visual significance of the load cell debris flag.

9.7.1 Architecture Evaluation

At this stage in WFM's development, five case studies had been considered: visualizations in harbour wall, shipwreck, pipeline (post survey and real-time) and debris recovery. The case study architectures were subsequently compared and analysed for similarity and uniqueness. The objective of this exercise was not only to question why similarities or differences existed, but also to see if a set of rules could be constructed to facilitate with the pre-construction of a WFM architecture prior to an offshore activity.

Areas of Similarity and Commonality Between Architectures

- Networking and BlueBox systems
- WFMCore
- RBS database
- DDT
- Palette
- WFMView
- WFMTerrain
- WFMModel

9.7 Summary

Predictably, the area of commonality across all architectures considered in this and previous case studies is the visualization of seabed terrain. These elements require the DDT, Palette, and WFMTerrain modules and also require the BlueBox sonar system to gather the bathymetric data. The rendering module, WFMView, is required to display the 3D scene (previously constructed from the mapping modules). The WFMCore is required to handle certain boot-strap graphics elements (as described previously).

These foundation elements will be required in future offshore activity visualizations and could be introduced as a default template upon which to base WFM architectures.

Areas of Uniqueness Between Architectures

The unique elements of the architectures to-date are:

- WFMPipeline
- WFMHarbourWall
- WFMCrane
- WFMDredger

The WFMPipeline and WFMHarbourWall modules, although specific to their individual activities (pipeline and harbour wall visualization), are not specific to all surveys per se (such as WFMTerrain). Although it is unlikely that an offshore engineer would require a WFMPipeline module for the visualization of a shipwreck, the engineer would require the module for another pipeline survey in the future.

WFM objects can be identified as complex objects or simple objects. Simple objects are objects that are positioned in 6D⁴ based on time. Complex objects are objects that must still be positioned in 6D but also have more complex movements. In the case study outlined in this chapter, the ROV was a simple object. Although it had internal model motion (multiple spinning propellers), it only required positioning in 6D. The crane system was a complex object (arm movements and rotations) and therefore a special WFMCrane module was required to handle the dedicated data streams.

⁴6D: Easting, Northing, depth, yaw, pitch, roll.

9.7 Summary

Complex object modules such as WFMCrane and WFMDredger are hardware specific and are unlikely to be used in later offshore activities.

The above observations have resulted in three categories of modules for the WFM architectures:

1. Template modules that will be found in any offshore visualization architecture (covers terrain rendering etc).
2. Activity specific modules (such as WFM Pipeline) that can be re-used regularly. These activity specific modules can be selected from a growing repository of WFM modules.
3. Unique modules (such as WFM Crane and WFM Dredger) which are generally specific to an individual survey such as an unusual item of hardware.

Considering the experience gained from the previous case studies and the architectural observations described above, a set of guidelines was identified for facilitating in the construction of offshore visualization architectures.

Guidelines for Defining a WFM Architecture

1. Understand the offshore activity. A thorough understanding of the offshore activity is imperative and includes a knowledge of processes and procedures (especially for complex real-time offshore visualizations). Drawing a state diagram of the offshore activities (such as Figures 8.13 and 9.5) can be helpful to the offshore engineer.
2. Understand the visualization requirements. Which items of the offshore activity are important for visualizing? All activities and objects will not necessarily need to be displayed. This step involves the identification of a subset of objects that will need rendering. In the case study described in this chapter, the important objects would be the seabed terrain, barge, crane and ROV.
3. Build the WFM architecture. Start with the template modules, identified above, and then introduce the activity specific modules available from the WFM module repository. Simple dynamic 3D objects may be positioned using the activity specific module WFMModel. The 3D model geometry for the module (if it does not exist

9.7 Summary

within WFM's model repository), will need to be generated using a modelling package such as 3D Studio Max.

4. Identify and fill gaps in the architecture. Gaps in the architecture will probably signify the demand for unique modules that are not currently available in the WFM repository. These will generally be required for objects that cannot be visualized using the WMFModel module. For example a complex crane lifting system. Such modules require a programmer to develop and compile the required module.

9.7.2 Real-time modelling of the Kursk Recovery

This section shows how the guidelines from Section 9.7.1 can be used to generate a proposed WFM architecture for the real-time recovery visualization of the Kursk nuclear submarine. The wreck of the Kursk (which sank in August 2000 killing all 118 crew members) was successfully raised from the seabed in October 2001. The process involved the use of 26 steel cables that connected the 18,000 tonne submarine to a Dutch-owned Giant pontoon. WFM had no part to play in this recovery procedure and the author is unaware of what software was used to facilitate operations. This section serves only to provide an example of how a WFM architecture may be prototyped using the guidelines from Section 9.7.1.

Step 1 - Understand the offshore activity

A thorough understanding of the offshore activity would be achieved through numerous meetings with Dutch offshore companies and the Russian Navy. For the simplified example described in this section, information relating to the recovery was gained from news channels and the Internet (Cable-News-Network 2000). The aim of this offshore visualization would be to provide a real-time 3D display of the recovery procedure.

Step 2 - Understand the Visualization Requirements

A careful analysis of task operations and procedures (extractable from item 1) would enable the offshore engineer to identify a subset of objects that would need rendering. A preliminary subset for this offshore activity would include:

- The seabed surrounding the Kursk.

9.7 Summary

- The Kursk submarine (to be recovered).
- The lifting pontoon.
- The interaction between the pontoon, the 26 steel lifting cables and the submarine.

An accurate model of the Kursk submarine would be built through collaboration with the Russian Navy. The model (created in 3DMax) would then be augmented to include physical damage available from reports from initial wreck surveys. Lifting pontoon and cable CAD data would be available from the Dutch offshore companies and used to create the pontoon and lifting cables.

Step 3 - Build the WFM Architecture

Figure 9.12 shows the template architecture identified in Section 9.7.1 including activity specific modules (a WFModel for positioning the Kursk 3D model).

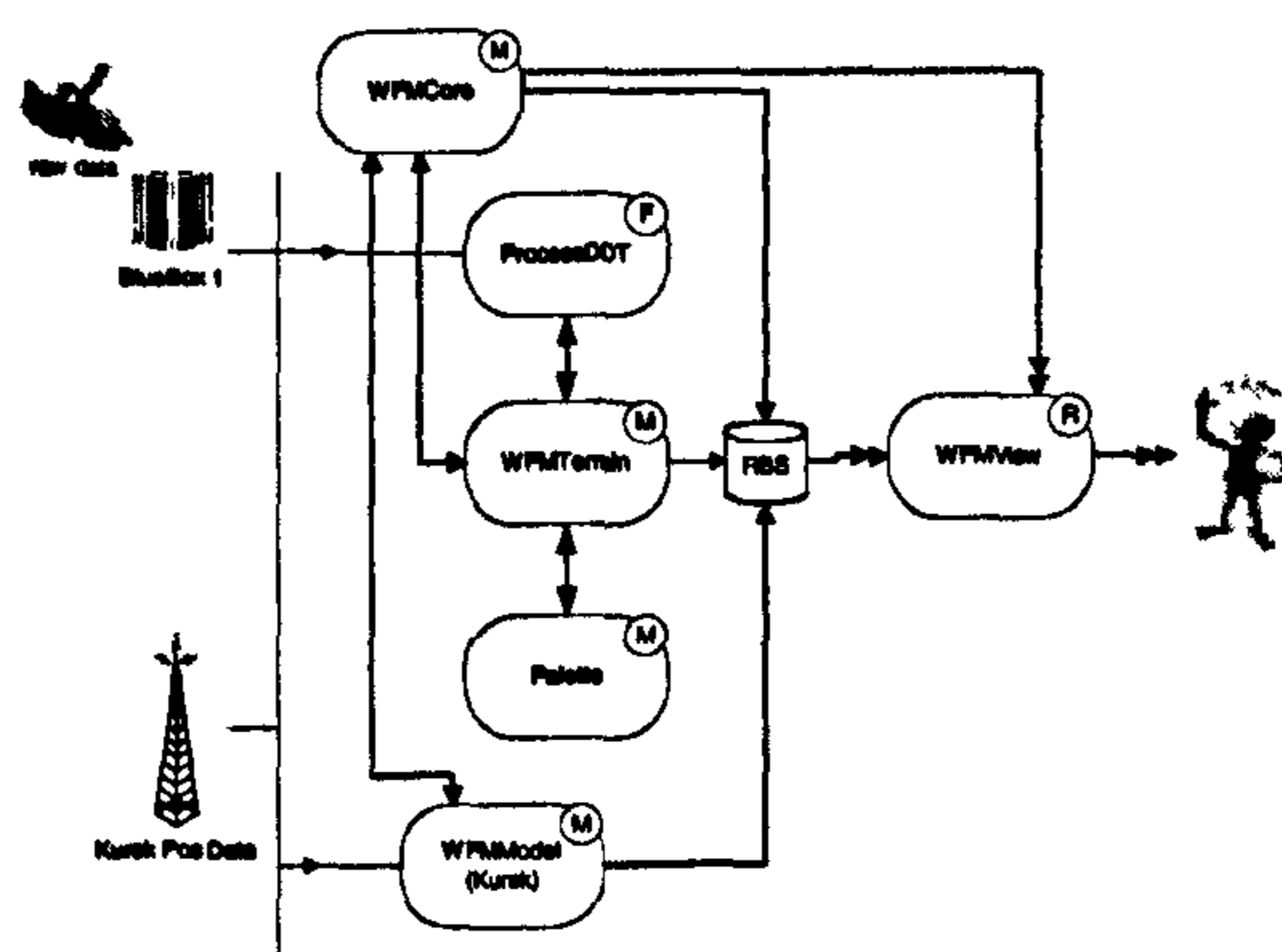

Figure 9.12: Kursk Architecture Step 1

The submarine model may be positioned using motion and position sensors applied along the surface of the vessel. If the spatial relationship between the sensors starts to change during the recovery procedure, then this will give a good indication that the vessel is breaking up. During a healthy recovery procedure, the distance between sensors should remain fairly constant.

Step 4 - Identify and fill gaps in the architecture

The gaps in the architecture described above are clearly visible when reconsidering the initial components for the visualization identified in Step 2. Section 9.7.1 stated that gaps in the architecture will probably signify the demand for modules that are not available in the WFM repository. In this instance, a module is required for the control and positioning of the Dutch pontoon vessel and the visualization of the 26 metal cables.

The positioning of the pontoon itself is fairly trivial. However, positioning of the 26 cables requires a little more consideration. In the early stages of this chapter, a crane load-cell was used to determine if debris was being lifted off the loch floor. This was a boolean operation, either the visible debris flag was set or it was not (based on a predetermined load-cell threshold). In the Kursk example, 26 real-time load cell data streams will be fed into the WFM system. The viewer is interested in the stress level on each cable (evident from the cable's load cell). WFM must draw the viewer's attention to important events such as a cable approaching its stress limit. This can be achieved by attaching a palette object to the created WFMPontoon module in order to colour each of the cables based on their loads. Instead of querying the palette module with a depth value, the WFMPontoon module now queries the palette module with a stress level. A low stress cable could be textured white whereas a highly stressed red cable may require immediate attention (perhaps pulling more on the other cables and relaxing the red cable). Extra BlueBoxes may be used to track intermittent pingers placed on the cables to facilitate underwater tracking and positioning of the underwater cables.

Figure 9.13 provides an initial architecture for the visualization of this recovery procedure and would enable the offshore engineer to view the Kursk submarine, pontoon, stress colour coded lifting cables and seabed all correctly positioned and orientated in real-time during the recovery process. The architecture was developed using the guidelines stated in Section 9.7.1.

The WFM visualization for the Kursk's recovery is a theoretical simplified example of how WFM can be used for other complex offshore visualizations and provides an example of how the WFM architecture can be augmented for various offshore activities.

9.7 Summary

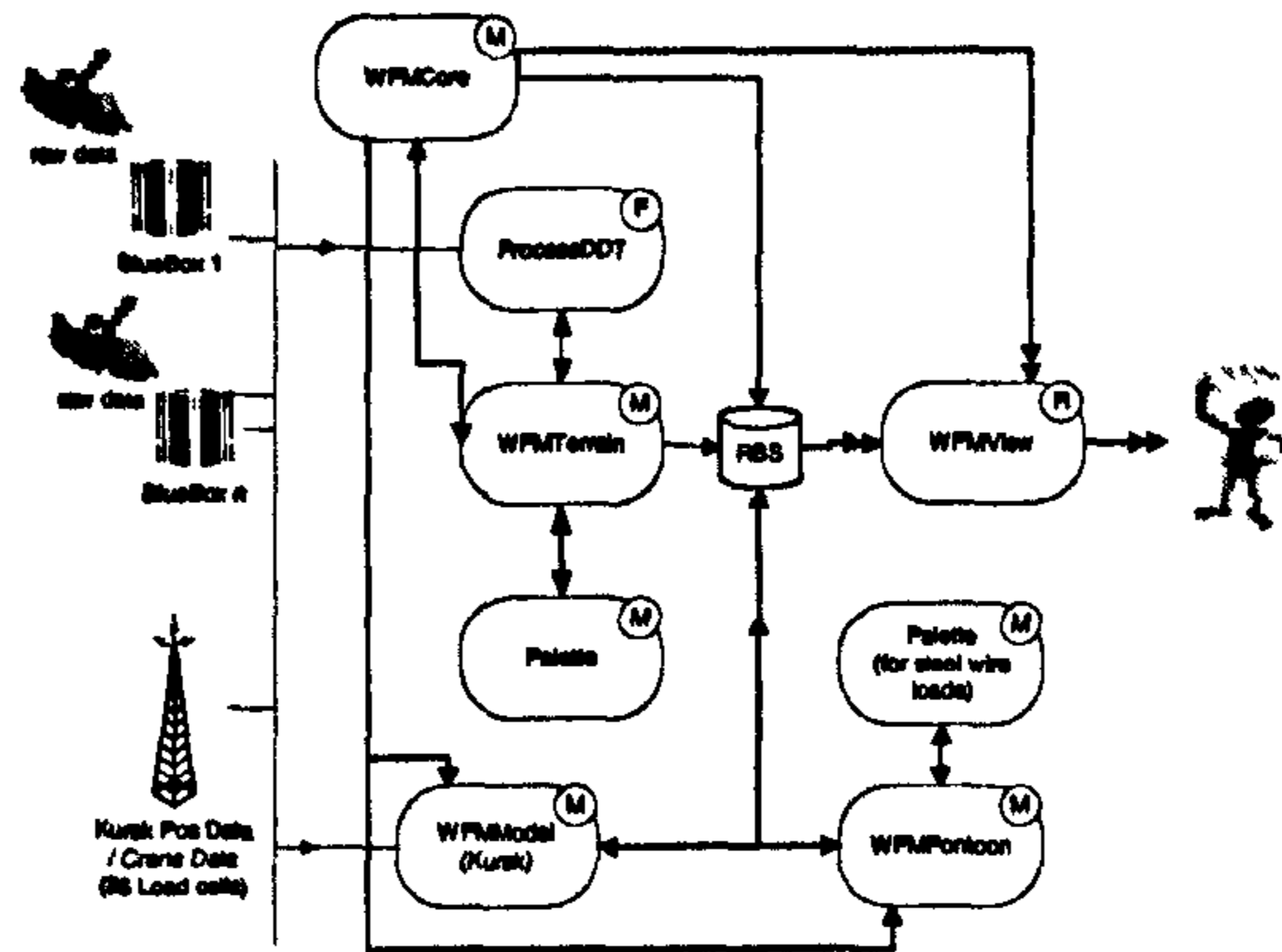

Figure 9.13: Kursk Architecture Step 2

9.7.3 Case Study Evaluation Map Appraisal

It can be seen from the case study evaluation map in Figure 9.1 that all major requirements for an offshore visualization system have been addressed except the inclusion of real-time high resolution terrain updates. The case studies described in this and the previous chapter both used dynamic terrain that updated 'patches' of seabed upon request. One area of terrain visualization that has not been considered is the real-time visualization of terrain focusing on an individual 'per-ping' update. The diamond mining case study in the following chapter addresses this requirement and therefore completes the offshore visualization requirements outlined in Section 4.4.

Chapter 10

Diamond-mining Visualization

The terrain visualization in the previous two chapters used a dynamic terrain model which involved updating the seabed geometry in patches. The aim of this chapter is to investigate if the terrain can be modelled in real-time on a per ping basis. This means that as soon as a single ping datum becomes available from the scanning system, the 3D terrain visible to the viewer will be updated. This differs from previous approaches of updating a patch of seabed in a single step from a pre-processed digital terrain map. The case study evaluation map for this chapter can be seen in Figure 10.1.

An ideal offshore scenario for considering real-time terrain updates is dredging. In the first WFM real-time offshore visualization described in Section 8.5, a dredger was used to dredge a short section of pipe. At the end of each dredge run, a second sweep was required to survey the entire dredge section. If the seabed was continuously scanned during the dredging process and this data was streamed into WFM, then it may be possible to visualize dynamic real-time seabed during the dredging process. The dredging activity chosen for researching and implementing this concept is diamond mining off the coast of Namibia in Africa.

The objectives of this case study are twofold:

1. To consider real-time per ping updates to seabed terrain.
2. To consider how offshore staff interface to a 3D graphical visualization of the diamond mining process.

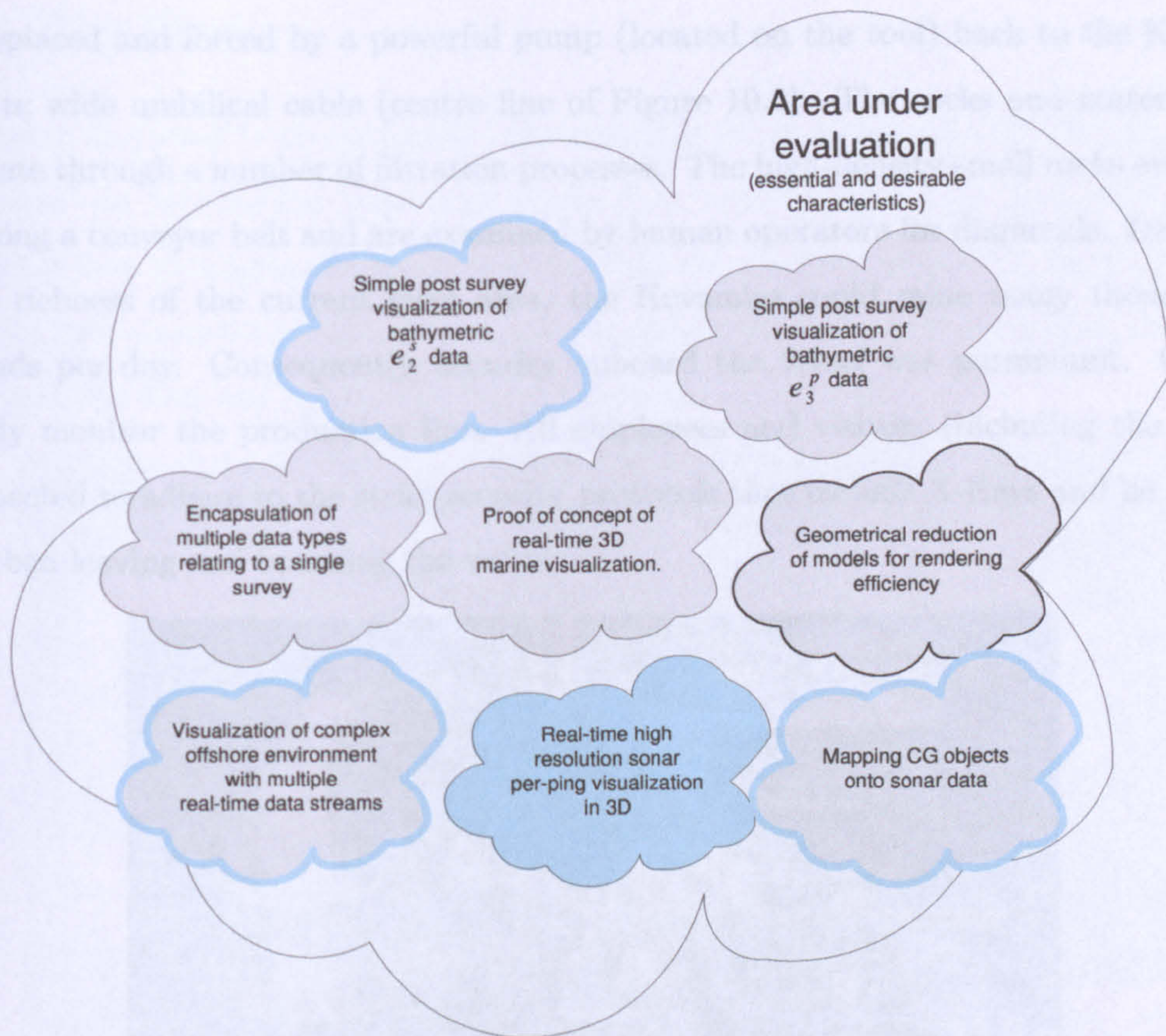

Figure 10.1: Case study evaluation map

10.1 Introduction

This case study describes how WFM has facilitated operations within the offshore diamond mining industry by providing the crew of the MV Kovambo with a real-time visualization of a diamond-mining tool and its surrounding seabed. This WFM Visualization System was implemented by the author onboard the MV Kovambo off the coast of Namibia between August and September 2000.

10.2 The MV Kovambo Diamond Mining Vessel

The MV Kovambo (Figure 10.2) is a state of the art diamond mining vessel owned by Namco Diamond Mining Ltd. The Kovambo houses a large diamond mining crawler system called the tool that crawls over the seabed floor at approximately 75m water depth. By repeatedly hammering its knuckle-head on the rock surface, large chunks of rock and seabed are broken

10.2 The MV Kovambo Diamond Mining Vessel

and displaced and forced by a powerful pump (located on the tool) back to the Kovambo via a 1m wide umbilical cable (centre line of Figure 10.2). The rocks and material then propagate through a number of filtration processes. The high-density small rocks eventually pass along a conveyor belt and are examined by human operators for diamonds. Depending on the richness of the current farm area, the Kovambo could mine many thousands of diamonds per day. Consequently, security onboard the vessel was paramount. Cameras carefully monitor the production line. All employees and visitors (including the author) are expected to adhere to the strict security protocols that include X-Rays and lie detector tests when leaving and boarding the vessel.



Figure 10.2: MV Kovambo Diamond mining vessel

10.3 The Tool

The mining tool itself is an extremely large crawling device weighing over 180 tonnes. The tool's torso can turn on the large tank tracks that move the tool over the seabed. Figure 10.3 shows four photographs taken by the author showing the crawler being deployed. A special 12 inch diameter metal rope and associated computer controlled spooling device lifts the tool off the deck and lowers the tool down to the ocean floor.



Figure 10.3: Photographs of the 180 tonne crawler being deployed

The tool can spend many days mining on the ocean floor and will not be recovered unless impending bad weather, breakdown or maintenance causes mining operations to cease. The size of the tool can be fully appreciated in the top right hand photograph of Figure 10.3 (note the maintenance engineers working on the tool towards the rear), and in Figure 10.4

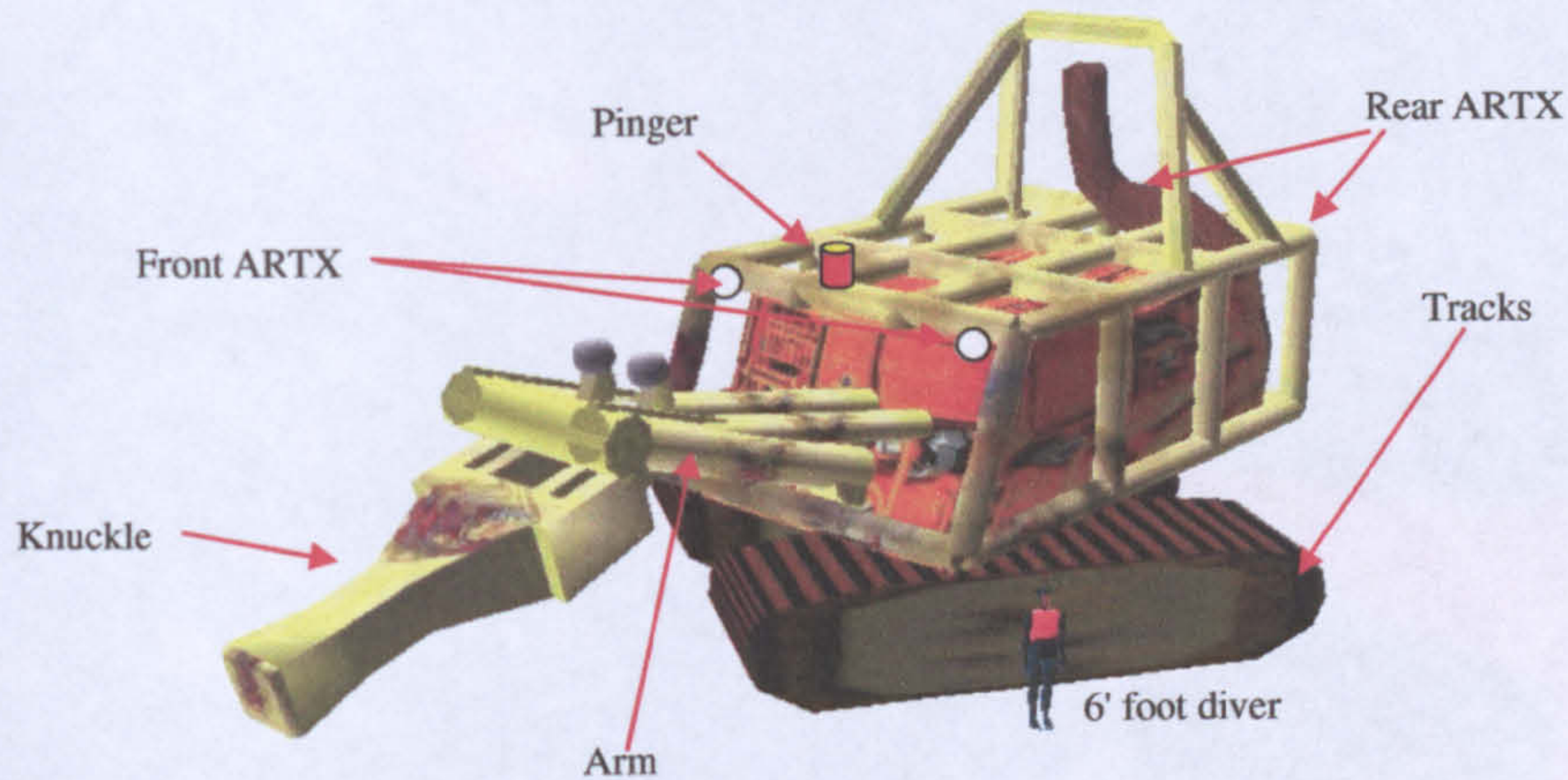

Figure 10.4: Computer model of the tool including correctly scaled 6 foot diver

which shows a correctly scaled tool and diver standing 6' tall.

The WFM tool model used for the mining visualization is shown in Figure 10.4. The model was created using 3DStudio Max and then imported into WFM. All moving parts on the crawler are then controlled by the WFM software. An ARTX sweeping sonar transducer system is mounted on each corner of the tool to scan and image the seabed topography in front of, and to the rear of the tool's torso. For positioning purposes, the tool will continuously broadcast an acoustic signal via the pinger (mounted on the crawler's back) through the water-column which is detected by a dedicated BlueBox system.

10.4 Original Mining System

The Tool is controlled from the Tool Control Cabin (Figure 10.5) located towards the rear of the vessel. The original mining system, prior to WFM's installation, consisted of two plan views of the tool visualizing the arm and torso rotation angles. With the original mining system, the tool's surrounding seabed topography was not visible to the pilot. Topography of the seabed directly in front of the tool was approximated using a profiling sonar system that, to the trained eye, provided an indication of the height of a rock face directly in front of the tool.

Traditional real-time dredging software such as DredgePack (Coastalo 2000) was introduced to the reader in Section 4.2.3. DredgePack is a real-time dredging visualization

10.5 Proposed Visualization System



Figure 10.5: Tool control cabin

system providing 2D real-time digging information for cutter suction, hopper and excavator operators. An example Dredgepack display is shown in Figure 10.6. The next section proposes a real-time 3D display of the dredging process provided by WFM.

10.5 Proposed Visualization System

The objective of this mining visualization project was to provide the tool pilot and other interested parties with a real-time display of the tool's position and orientation, including an accurate visualization of its arms, tracks and torso. The system was also designed to provide the client with true real-time visualization of the seabed topography using individual pings direct from the sonar transducers. This had never been achieved before within WFM. The objective was to continuously and dynamically update the terrain map with each individual ARTX sweep.

As described in Section 10.3, each corner of the tool housed an ARTX sonar transducer system. An ARTX sonar system will sweep its array over the seabed. For example scanning between -30 to +30 degrees of seabed. Consequently, even if the tool is stationary, a section

10.6 Diamond Mining Visualization Architecture

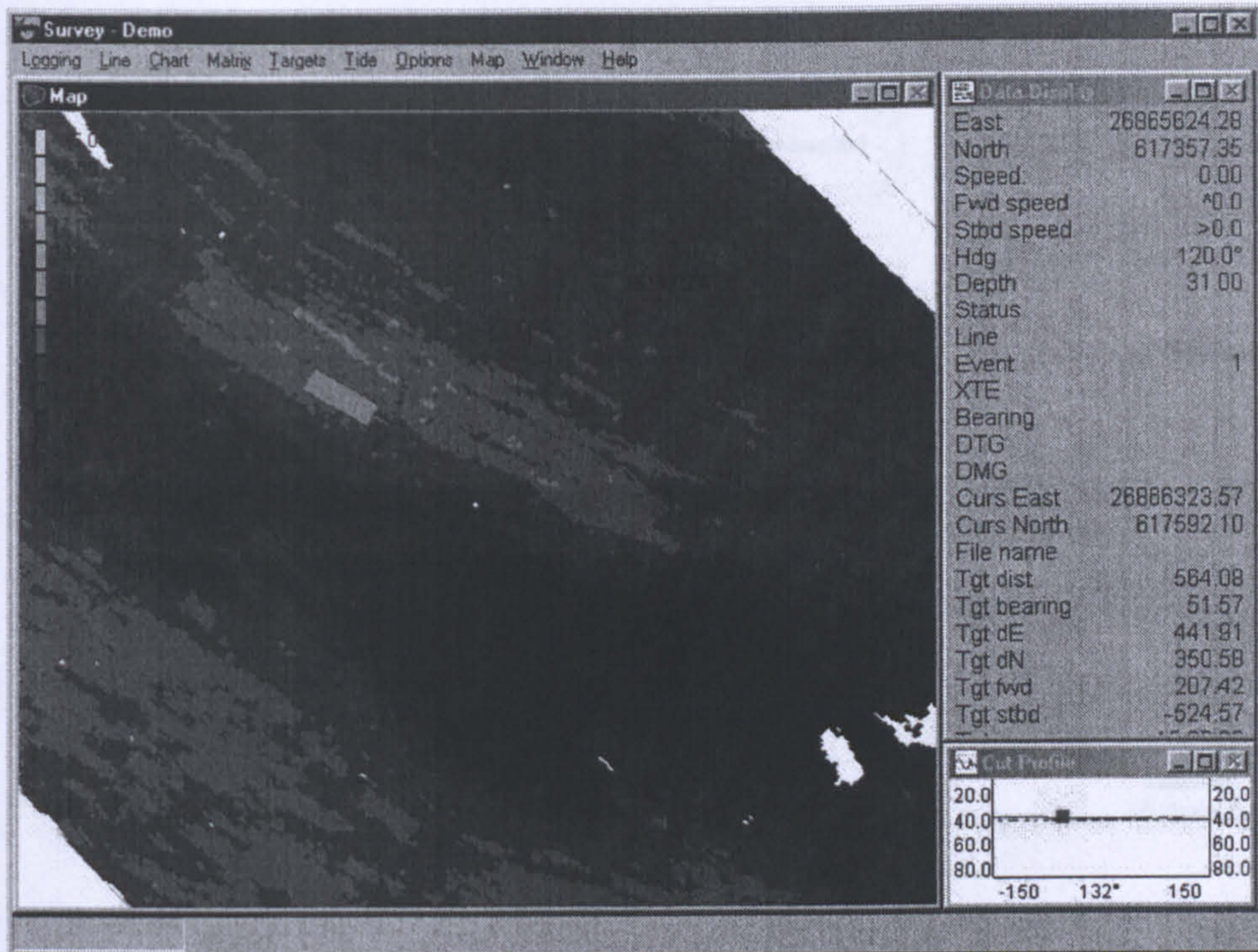

Figure 10.6: Sample screen shot from DredgePack (Coastalo 2000)

of seabed in front and behind the tool may be continuously scanned.

10.6 Diamond Mining Visualization Architecture

Figure 10.7 describes the WFM architecture used for the real-time diamond mining visualization. New modules include ProcessPings, WFMTerrainD, WFMTool and a second BlueBox (BlueBoxB) that is used to track the underwater tool's pinger.

10.6.1 ProcessPings Filter Object

The ProcessPings filter object was responsible for taking real-time sonar data and converting it into corrected data points. These data points were then streamed into the WFMTerrainD mapping object described in Section 10.6.3

10.6.2 WFMTool Mapping Object

The WFMTool map object was responsible for updating the RBS with the new position of the tool. This information would include the tool's position in Easting and Northing, torso

10.6 Diamond Mining Visualization Architecture

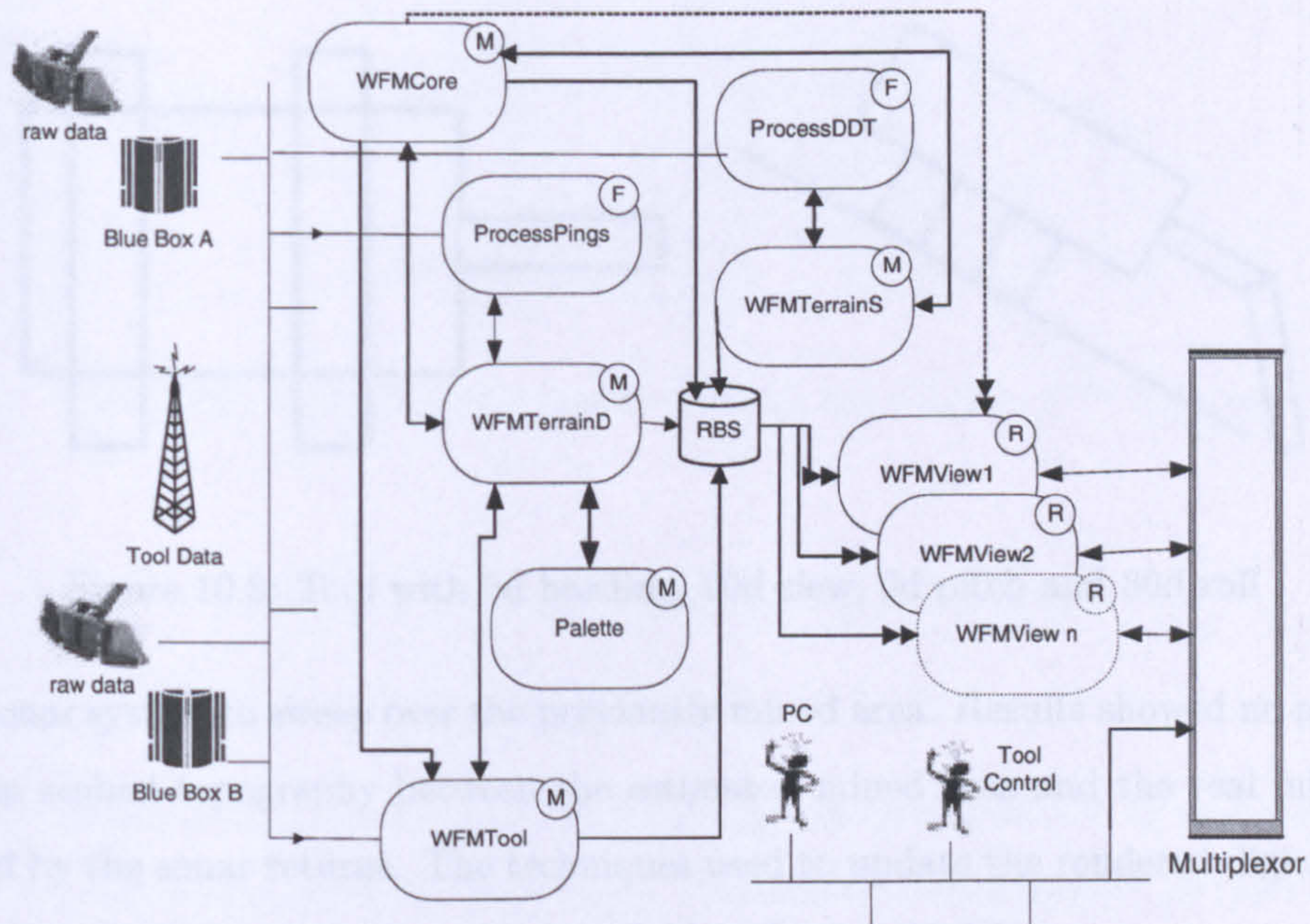

Figure 10.7: Diamond mining architecture

rotation, track rotation (tool heading), pitch, yaw, roll, and the arm and knuckle angles. The tracking and positioning of the tool was achieved using exactly the same techniques described in the ROV tracking for the debris clear up operation described in Chapter 9.

Section 10.2 described how the mining tool's knuckle repeatedly hammered the seabed floor, sending the broken pieces to the MV Kovambo via a 1m diameter umbilical hose. Consequently, the real-time visualization needed to show the knucklehead scouring and mining the dynamically rendered seabed. No transducer systems were mounted on the knuckle because it would be impossible to process any sonar data due to the noise created from the mining process. Therefore to visualize the mining process, the WFMTool object sent the WFMTerrainD object a section of seabed that represents the area and depth of the knuckle's tip (the knuckle's footprint). An assumption is made that if the tool is mining, no terrain can be above the knuckle. By constantly reducing the depth of the seabed directly under the knuckle's tip, an effective visualization of the tool mining process can be produced.

The rendered seabed representing the tool tip mined area is an approximation of the terrain. These mining estimates are validated every time the crawler slews forcing the

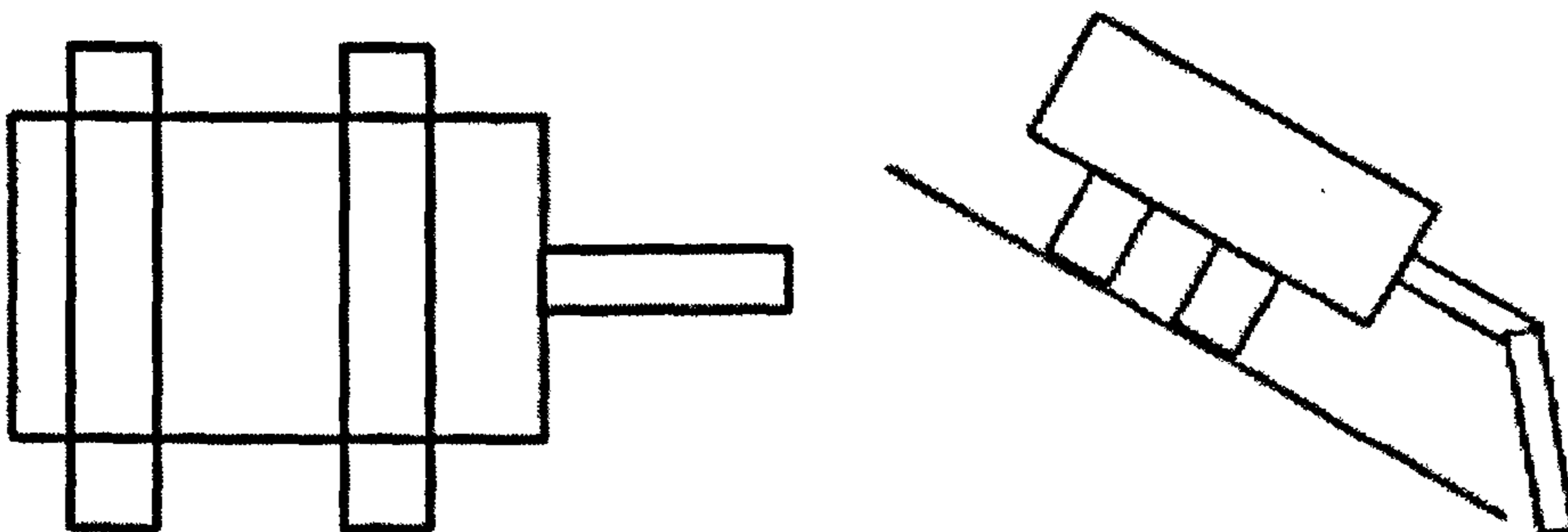

Figure 10.8: Tool with 0d heading, 90d slew, 0d pitch and 30d roll

ARTX sonar system to sweep over the previously mined area. Results showed no noticeable change in seabed topography between the estimated mined area and the real mined area produced by the sonar returns. The techniques used to update the rendered digital terrain maps from individual sonar pings are described in Section 10.6.3.

Tool Mechanics

The tool was located underwater in much the same way as the ROV was tracked in Chapter 9. Multiple pingers were placed on the torso of the tool and were tracked by a dedicated BlueBox system. A motion device attached to the torso provided rotational information for WFM.

Rotational adjustments were needed when the tool started to slew about its tracks. The motion sensor is oblivious to the relationship between the tool torso and the tracks and will continue to provide rotational data that is torso specific. Consequently, a 90 degree torso yaw or slew followed by a crawler roll will be identified as a slew pitch.

For example, Figure 10.8 illustrates an example where the tool torso has slewed to +90 degrees from the tracks, a 30 degree roll (shown on the right of the diagram) will be registered by the motion tracker as a 30 degree pitch.

Table 10.1 considers an example crawler pitch of 30 degrees and roll of 10 degrees under various slews. The crawler pitch and roll can be calculated using the sine and cosine weighting functions using the motion sensor results (Equations 10.6.1 and 10.6.2).

$$trackPitch = pitch * \cos(-slew) + roll * \sin(slew) \quad (10.6.1)$$

10.6 Diamond Mining Visualization Architecture

Slew Angle	Pitch	Roll
0	+30	+10
90	-10	+30
180	-30	-10
270	+10	-30

Table 10.1: Motion sensor results for a 30 deg pitch and 10 deg roll

$$\textit{trackroll} = \textit{roll} * \cos(-\textit{slew}) + \textit{pitch} * \sin(-\textit{slew}) \quad (10.6.2)$$

10.6.3 WFMTerrainD Mapping Object

The WFMTerrainD map module was developed for processing terrain dynamically by updating a terrain dataset on a per ping basis. Previous real-time terrain updates imported large areas (or patches) of seabed or digital terrain maps in a single batch.

The exact definition and requirements of a real-time system depend on its application. For example, the WFM Holy Loch clearance operation described in Chapter 9 updated the terrain within the model as soon as a complete sonar survey had been completed. For example, the transducers will initially survey an area of seabed. This data will then be converted into digital terrain maps and then rendered by WFMView. This application can still be defined as using real-time terrain. However, real-time definitions vary as the requirements change. Real-time terrain updates within Holy Loch may be performed and updated within the computer model every 40 minutes (typical interval between surveys). With the diamond mining application, the tool is continuously scanning a small area of seabed at high resolution with terrain updates required at over 30 times a second. Real-time for this application requires an update to the terrain model as soon as a specific ping has been detected from the transducer. Consequently, a new WFM module was developed for efficient terrain manipulation: WFMTerrainD.

To permit real-time updates to the terrain, a vertex map and a face map was used to facilitate dynamic indexing of vertexes and faces (polygons) using fast lookup tables. The vertex map and face map allowed the WFMTerrainD module to quickly index the relevant areas of memory for a given Easting and Northing. Some high-level pseudo code describing

10.6 Diamond Mining Visualization Architecture

how a ping is inserted into the model is presented below:

BEGIN new ping added

If the new ping does not have an associated vertex

Generate a vertex for the ping and index it in the VertexMap

Check the new vertex's neighboring points to see if any new faces can be generated.

If any faces can be generated

Generate the new face(s) and store an index to each face in the FaceMap

Else

Modify the associated vertex depth with the sonar ping's depth

Make a list from the FaceMap of all faces that use that vertex

Recalculate each face's lighting parameters and store in the RBS

END new ping

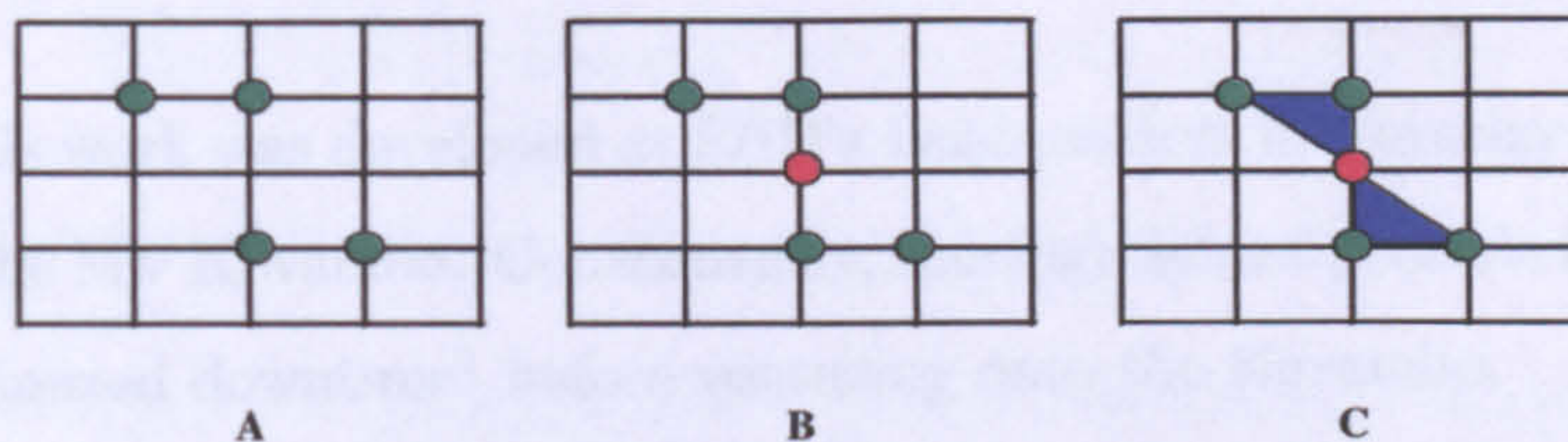

Figure 10.9: Inserting a new face from a ping

Figure 10.9 shows how a new ping is added to the RBS. In *A*, the vertex map consists of four pings, yet a polygon cannot yet be drawn because no data lies in-between the pings. A polygon could be drawn to approximate the data yet this would assume that data lies in-between the data-points. Assumptions cannot be made as experience has shown that they can prove to be expensive mistakes. It is better to display no data than incorrect data.

The new ping is added in *B*. The red ping is new data for that point and consequently a new vertex is created and added to the RBS. A reference is stored in the vertex map's fast lookup table. All neighbouring points are then checked around the new red point for possible polygon generation. It can be seen in *C* that two polygons can now be generated from the inclusion of the new sonar ping from *B*. Each new face is stored in the face map look up table. Each vertex will also record which face it is associated with so that they can be processed quickly if a different depth is recorded at that point as faces effected by

10.7 Results

a modified vertex must be re-rendered to accommodate any changes in depth colour and lighting.

The WFMTerrainD module fixed the colour of each vertex after lighting calculations had been performed. This resulted in higher render rates due to the exclusion of any further lighting calculations. An alternative would be to use traditional dynamic lighting calculations. For example, constantly recalculating the shading of polygons using the Gourard model on a per frame basis. Fixing the lighting and colour of a vertex requires only an initial calculation and can result in significantly faster rendering. The drawback of such a technique is that more storage is required to record a database of terrain as the vertex colours also need to be stored.

10.7 Results

The majority of this work was developed at SRD's headquarters in Beverley using captured data strings from the MV Kovambo. Consequently, this highlighted possible implementation problems and minimized downtime¹ before venturing onto the Kovambo.

This section considers WFM's performance based on the two objectives outlined at the beginning of this chapter.

The WFM diamond mining visualization system provided real-time data to the tool control cabin and Bridge. Figure 10.10 shows the tool's position after being lowered onto the seabed. The seabed was generated from a surface scan and facilitates the process of driving the tool to the current mining area highlighted in Figure 10.10.

The bathymetric terrain rendered from the sonar systems was texture coloured according to depth. The existing mining visualization systems were not depth corrected for the pitch of the tool making digging to a fixed depth difficult. Figure 10.10 shows how WFM pilots could dig to a specific colour depth (turquoise and dark blue representing un-mined and mined seabed respectively).

¹Downtime is the term used to represent non operational time (generally caused by equipment failure or bad weather).

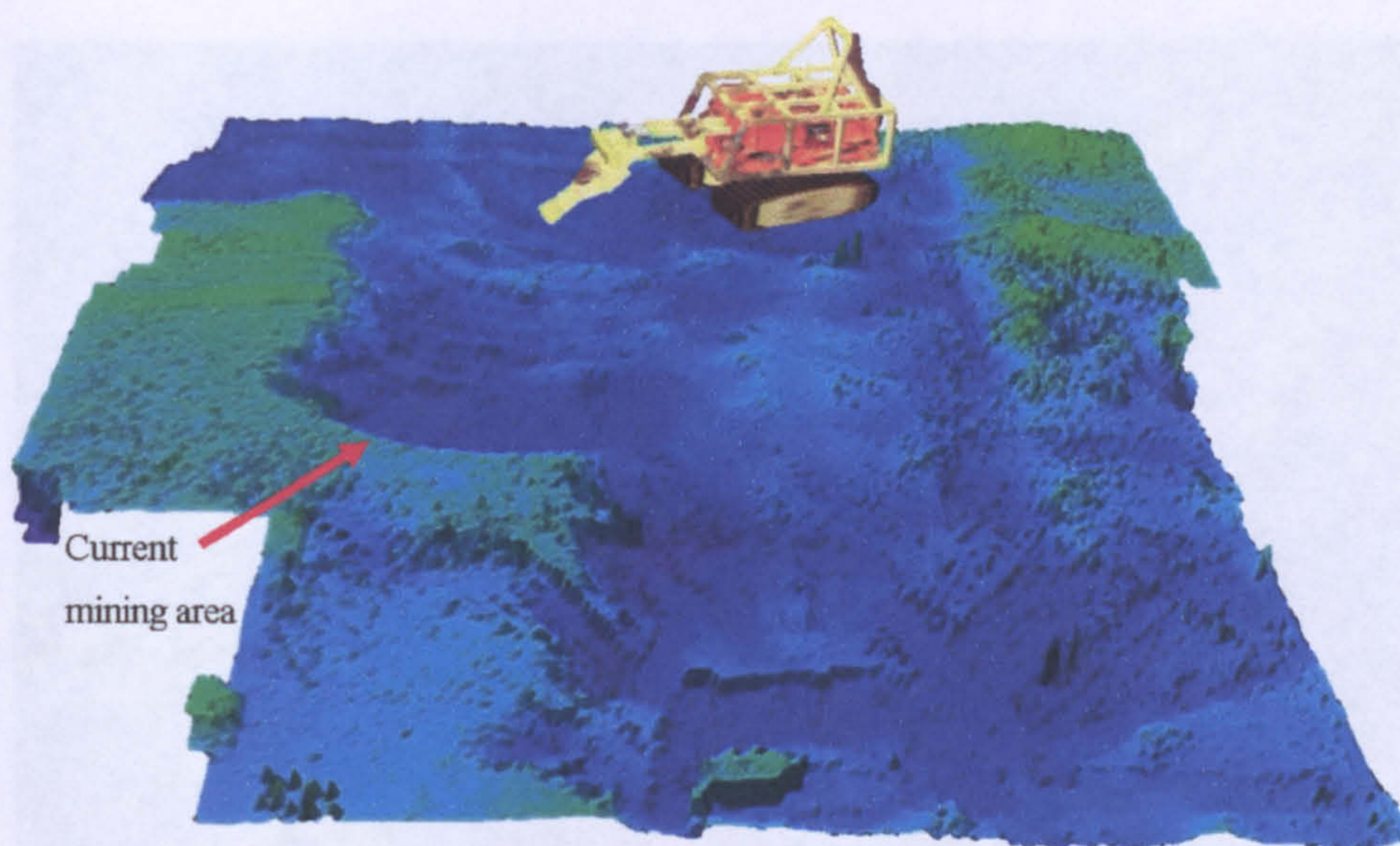

Figure 10.10: Real-time WFM crawler visualization

10.7.1 To Consider Real-time per ping Updates to Seabed Terrain

Figure 10.11 shows the real-time dynamic terrain in operation. The pilot can clearly see the exact position of the tool and the surrounding seabed topography. Note that the mined area (purple and blue) is a perfect fit for the stretch and radius of the crawler's arm. This is due to the tool slewing around its tracks to mine all the seabed within its reach.

The pilot had the facility to display tool information such as tool depth, heading, pitch, roll and slew of the torso. This information that includes a different camera view can be seen in Figure 10.12.

The small stalagmites visible in the above images are caused by noise from the sonar transducers. They are corrected (removed) as the ARTX sonar system sweeps back over the effected area. It is important to remember that this is a harsh underwater environment caused by pneumatic noise and silt and debris floating around the sonar transducers.

Figure 10.13 shows the WFM system implemented and in use within the tool control cabin. The pilot is using the WFM display to mine and manoeuvre the crawler. Pilots can select any viewpoint from a number of predefined cameras or they can define their own. Each pilot had their own camera view preferences. The pilot in Figure 10.13 has selected a bird's eye view of the tool.

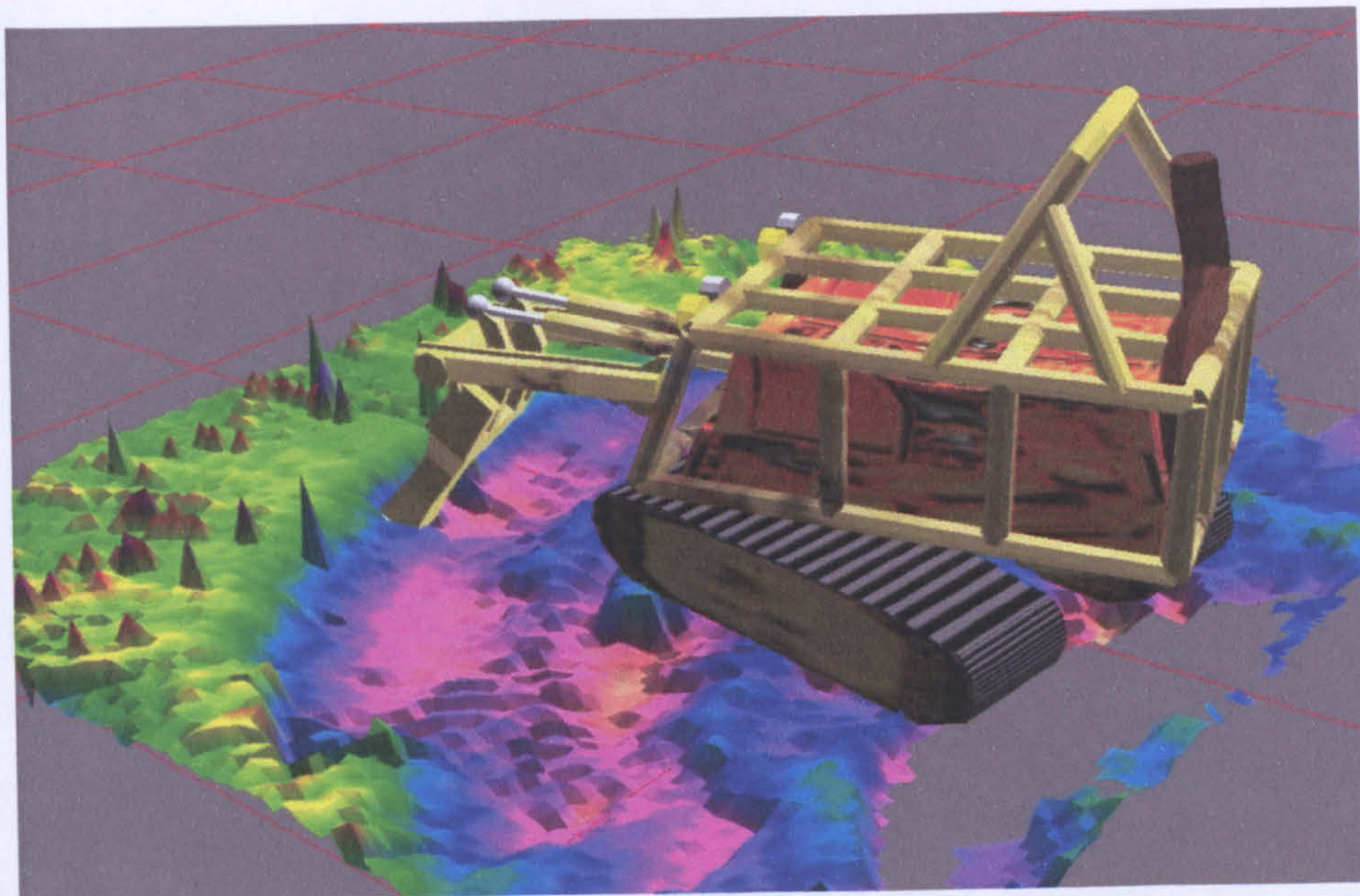

Figure 10.11: Real-time dredging display

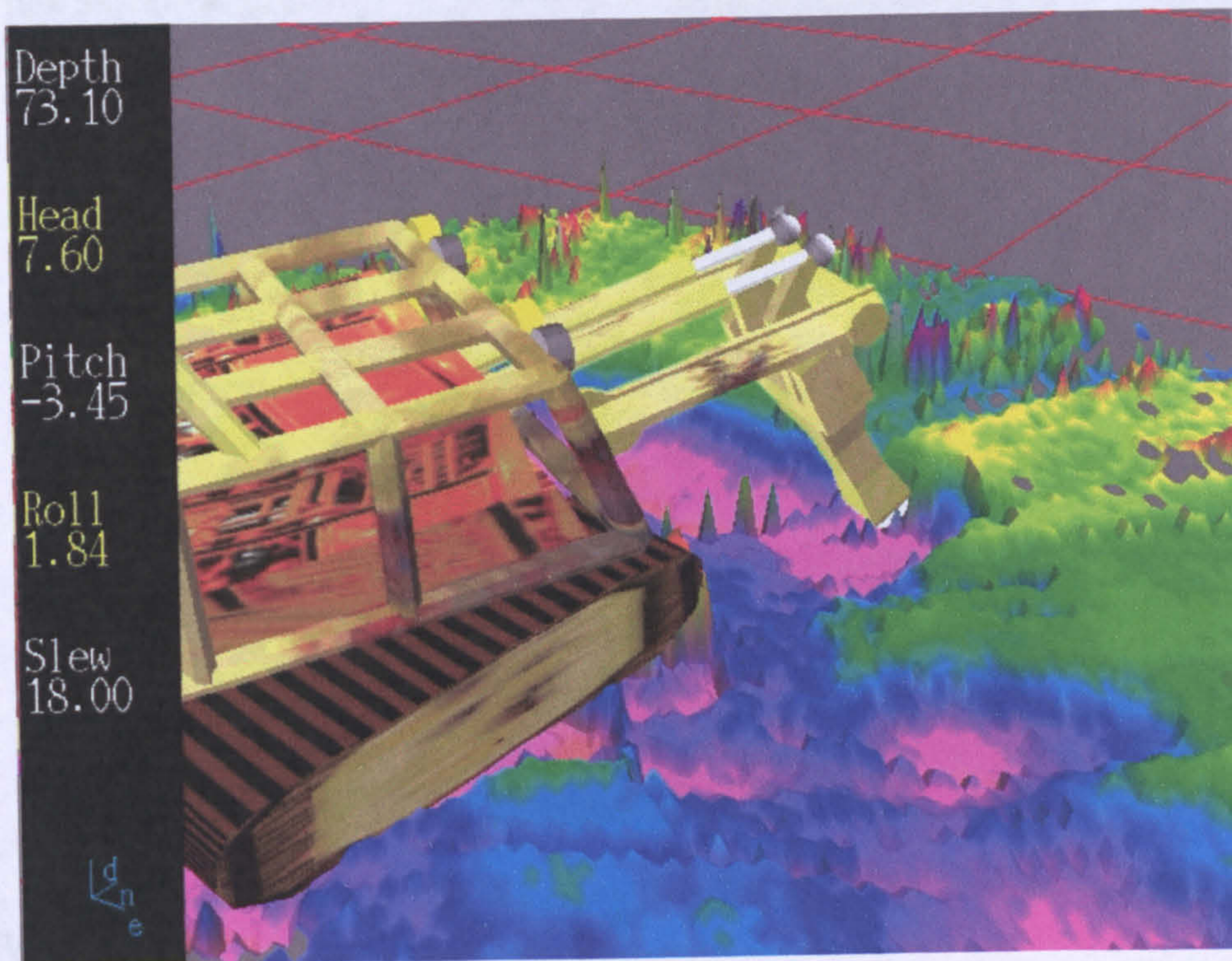

Figure 10.12: Real-time dredging display including crawler positional data (left)



Figure 10.13: Tool pilot using the WFM display (second display from top left) on board the MV Kovambo



Figure 10.14: Tool pilot using the WFM display (second display from top left) on board the MV Kovambo

10.7.2 Observations of Offshore Staff Interfacing to a 3D Graphical Visualization of the Diamond Mining Process

The WFM mining visualization system was initially presented to Namco's management in Cape Town, South Africa, on the 1st August 2000. Namco's management were impressed with the system and gave the go ahead for WFM implementation on board the Kovambo which was mining 20 miles off the coast of Namibia.

Upon arrival on the Kovambo, a demonstration and meeting was organised with all tool staff present. The objective of the meeting was to demonstrate WFM's mining system and answer any questions.

Initially there was significant animosity towards the system from the experienced tool pilots. All comments and questions seemed to be disparaging and it could be seen that they were unenthusiastic to adjust their operations to encompass this new system. A new mining control system was also planned for implementation together with WFM that would carefully monitor the pilots' production rates. This initial animosity and reluctance to change was due to the realisation that all mining procedures would now be carefully

10.7 Results

monitored and could be played back at head office. From the outset it was important to build up a good relationship with the tool staff and convince them that WFM's implementation was going to facilitate their mining operations and was not synonymous to George Orwell's 1984 (Orwell 1954).

Initial observations noted that the trainee pilots used the 3D WFM display as their primary information source. This was due to the natural viewing environment provided by WFM. Comprehending WFM's display required no mental interpretation of the data. Learning to read and understand the existing system could take several days.

The experienced pilots continued to use the original tools (due to years of repetitive and continuous mining) and would steal occasional glances at WFM for curiosity and to validate their own interpretation of the crawler's position. Over the following weeks, the experienced pilots realised how valuable the WFM mining visualization was for their work.

The pilots considered WFM to be especially effective at:

- Preventing tool stickages generally formed by digging a hole too deep and then not being able to track out of the hole. This was prevented because the pilots now had an accurate visualization of the tool's surrounding seabed.
- Monitoring deployment and recovery procedures (Section 10.7.3). A pre-survey and on-line deployment monitoring prevented lowering the tool into problematic areas.
- Mining to specific depths. Using the depth corrected colour bathy data.

It was also noted that outside visitors to the Kovambo such as high level management from Namco would use WFM as their primary information source within the tool cabin. Again this was due to the ability to extract more information from the WFM display than any of the other displays.

Some minor visualization modifications included co-ordinate systems. For example, the tool's roll, pitch and yaw displayed to the user via WFM must use the same co-ordinate system as the existing Kovambo systems. A positive roll must be displayed as a clockwise roll and a positive pitch describes a forward pitch.

10.8 Summary

10.7.3 Tool Deployment and Recovery

During diamond mining operations, the tool may need recovering from the ocean floor due to a number of reasons such as impending bad weather or tool malfunction. The recovery procedure consists of raising the tool from the seabed and placing it onto the rear of the vessel. During one such recovery procedure, the WFM visualization was not switched off. The motion sensor mounted on the tool continued to provide rotational data used for precisely orientating the computer model and the tool mounted pingers were still detected from the surface mounted transducer system. Subsequently, WFM continued to give an accurate depiction of the tool which included the recovery procedure (until 20m depth). This was a very interesting time as the engineers and scientists who had developed and created the tool saw for the first time a 3D visualization of the lifting process.

It was noted that if the process was reversed, WFM could be used to facilitate deployment (Figure 10.3) of the tool onto a pre-scanned seabed. There would therefore be no concerns related to deploying the tool onto an underwater ledge which could topple the tool. WFM subsequently proved to be effective at visualizing the tool deployment and recovery process. Figure 10.15 shows the tool being lifted from the seafloor using real positional data captured from the Kovambo. Of particular interest to the tool engineers and designers was the forward listing of the tool due to the immense weight of the tool arm, knuckle and tool-tip.

Visualizing the recovery and deployment of the tool provides the tool pilots and crew with an indispensable visual aid while executing a potentially extremely dangerous operation. It should also be noted that this recovery visualization is a successful working implementation of the proposed visualization for the lifting of the Kursk submarine described in the previous chapter.

10.8 Summary

Since WFM's implementation on the Kovambo, Namco have purchased another visualization system for their new diamond mining vessel, the YaTovio. DeBeers, the largest diamond mining company in the world, have also purchased two WFM systems for their diamond mining vessels.

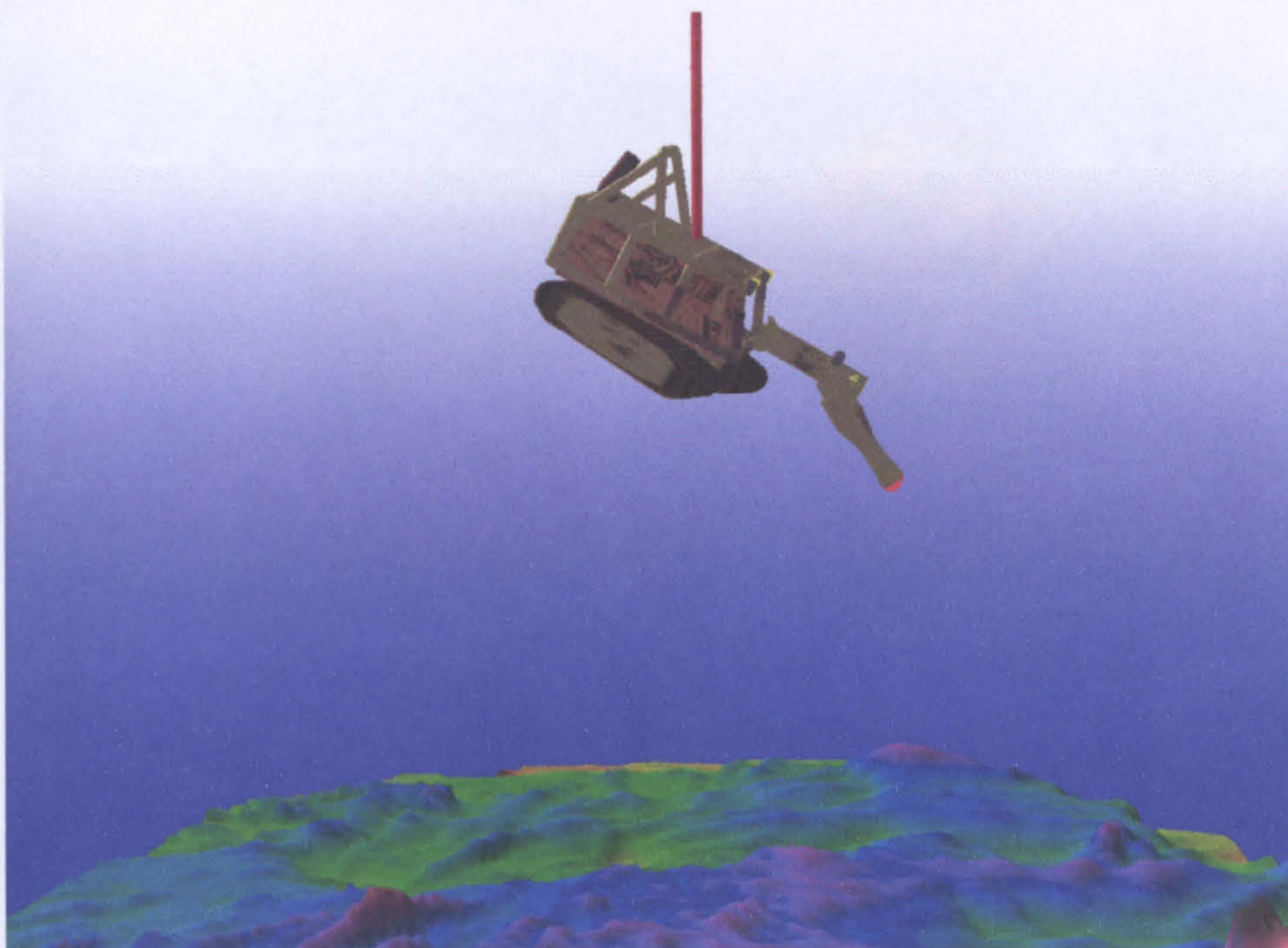

Figure 10.15: Tool deployment visualization

Due to the MVE architecture of WFM, very little work was required to modify the system for the DeBeers specification. A new WFMTool map object was required for the DeBeers's crawler, and a new 3D model replaced the Namco crawler. Figure 10.16 shows the display available to the Namco pilots. This example shows how straightforward modifications are within WFM's MVE architecture. The ability to effortlessly change the system's architecture to reflect changing job parameters was one of the initial requirements of WFM stated in Section 4.4. This exercise has proven how WFM can be quickly modified to handle various offshore requirements.

This chapter has described the first known implementation of an underwater 3D mining visualization system that provides real-time and accurate crawler tool positioning and dynamic per-ping seabed terrain updates within a virtual environment. The WFM system described in this chapter has replaced out-of-date 2D mining systems and is currently in use on a number of vessels owned by the two largest diamond mining suppliers in the world: Namco and DeBeers. The real-time per ping sonar terrain visualization is the last piece in the case study evaluation map that has been used throughout the last five chapters.

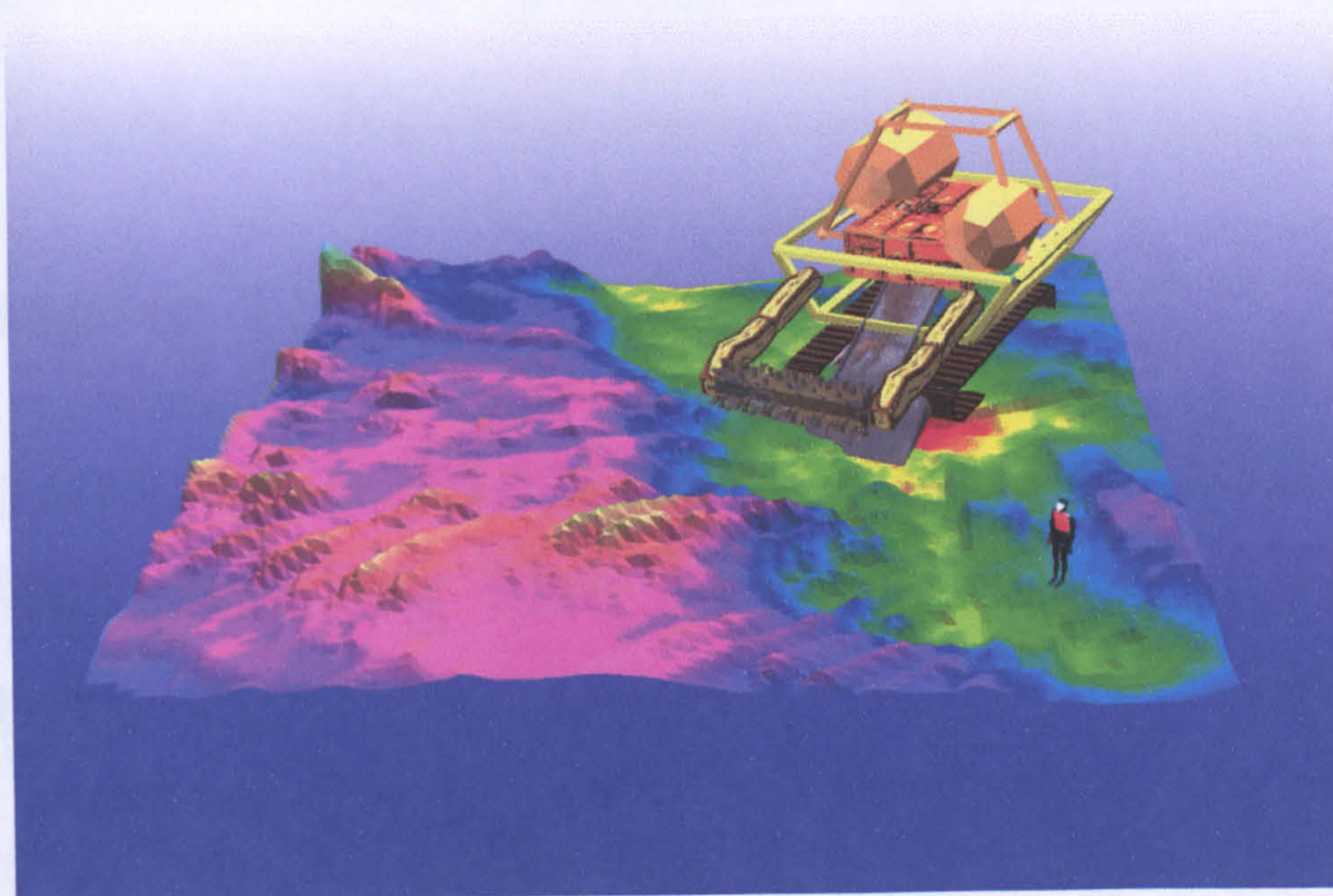

Figure 10.16: DeBeers real-time diamond mining

Chapter 11 completes the study of offshore visualization by considering how immersive visualization techniques such as virtual reality and immersive display technologies could be used to facilitate our comprehension of data gathered offshore. The Chapter is not linked directly to a specific case study but draws on the experiences and lessons learnt throughout the previous case studies.

Chapter 11

Immersive Marine Visualization - Augmenting the WFM Architecture

Previous chapters within this thesis have described the successful 3D visualization of offshore data and activities using traditional 2D monitor displays. This chapter considers the possibility of augmenting the WFM architecture to include immersive display technologies and to consider any benefits that would arise from their use. Immersive displays are considered within this thesis because in recent years these displays have greatly facilitated the visualization process (VanDam, Forsberg, Laidlaw, LaViola & Simpson 2000) and it is therefore feasible that immersive visualization can also contribute to the visualization of offshore marine data.

Section 11.1 introduces the reader to immersive technology by presenting some hardware typically used for immersive displays within the computing industry. A sample set of industries that currently use, or are planning on using immersive visualization techniques for interpreting marine data are then reviewed in Section 11.2.

The practicalities of implementing offshore real-time immersive marine visualizations are considered in Section 11.3. The section investigates problems of vessel real-estate, stereo eye fatigue and the implications of relocating real-time displays to offshore offices.

The WFM architecture refinements needed to accommodate these immersive visualizations are described in Section 11.4. WFM is augmented to enable both stereoscopic and hemispherical rendered output. Two immersive visualization scenarios, line monitoring and tele-operations, are considered in Sections 11.5 and 11.6. Finally some static post survey

11.1 Introduction to Immersive Technology

stereoscopic and hemispheric visualizations depicting exposed and free-spanning pipeline data are described in Section 11.7.

11.1 Introduction to Immersive Technology

Immersive technology is the use of specialist hardware that provides the user with a greater sense of 'immersion' within a computer generated environment. The greater the sense of immersion within the environment, the greater the sense of 'presence'. Immersion within a computer generated environment is often achieved through the clever implementation of display technologies and specially built VR systems. Some example systems include:

- Stereo displays using projectors (work benches, wall projectors etc).
- Head mounted displays (HMDs).
- Hemispheric displays.

These technologies are briefly considered below:

11.1.1 Stereo Projection

Stereo workbenches and projectors provide the user with a stereoscopic view that is achieved through the use of flicker glasses. The lenses of these glasses use liquid crystal displays that act as blinds that control which of the user's eyes is open and which is shut. When the LCD is active for the left eye, the user can only see with the right eye and the computer displays the right eye image. The flicker glasses then blank the right eye and the computer shows the left eye image. The difference between these two images equates to a retinal disparity providing the user with the stereoscopic view.

In order to generate stereo images for flicker glasses, two separate images, one for each eye must be generated. Lipton & Halnon (1998) describe the mathematics required to calculate the position and orientation for each of the two cameras.

11.1.2 Head Mounted Displays (HMDs)

Head mounted displays can also provide stereoscopic views of a computer environment but generally only provide mono displays (ie the left eye display is identical to the right). Some

11.1 Introduction to Immersive Technology

HMDs permit the user to see beyond the computer generated view with precisely positioned mirrors and optical combiners. This enables the real view to be augmented with computer generated imagery¹. HMDs are generally heavier than LCD shutter glasses (due to the extra electronics), are more expensive and restrictive.

11.1.3 Hemispheric Displays

Displays such as the Elumens's VisionStation (Elumens 2002a) are immersive, multi-user single projector hemispherical display systems. They do not display in stereo and consequently users of these systems are not required to wear goggles, glasses, helmets, or other restrictive devices. These systems offer multi-user, multi-sensory displays for simulation, training, design, engineering, energy exploration and production, education, medical services and entertainment.

One advantage of using a hemisphere display is that the immersive experience is common to a group of people which facilitates collaboration on a project. The viewer experiences an improved sense of immersion because the display takes up the viewer's peripheral view.

Hemispheric Display Distortion

When an uncorrected planar image is projected onto the hemispheric display, it is spherically distorted. Consequently, the image must be pre-distorted before it is projected onto the hemisphere display.

Texture-mapping techniques used to produce non-planar spherical projections were first discussed by Greene in 1986 (Greene 1986). Elumens have developed their own SDK called the SPIClops API (Spherical Projection of Images) that uses texture mapping hardware to re-project planar perspective projection images on a sphere to create perfect spherical projections. By incorporating the API into a visualization system's display routines (such as WFM), a correctly distorted fisheye view can be projected. The Elumens VisionStation and VisionDome systems use a single projector and lens combination to provide the full 180-degree projection. This is achieved through a specially designed lens that provides a uniform distribution of pixels onto the hemisphere display.

¹'Augmented Reality' is now a very popular area of virtual environments and has huge potential in a number of application areas such as the medical and entertainment industries.

11.2 Current and Proposed Work with Immersive Marine Visualization Systems

This section considers previous, current and proposed immersive technology for interpreting marine data. Three applications are considered: BP's new Centre for Visualization, NOAA's Pacific Marine Environmental Laboratory and a proposed Virtual Great Barrier Reef Project.

11.2.1 BP Centre for Visualization

In late October 2001, BP Amaco opened their \$10.6m centre for visualization at the University of Colorado (BP 2001). The new virtual-reality chamber consists of three 12 foot screens that typically project marine data and volumetric seismology data sets such as an oil field (Figure 11.1). The viewer wears stereo glasses that also contain a tracking device enabling the rendering computer to update the visualization display as the viewer changes position.

'From finding oil and clean burning gas in the most environmentally sensitive way, to discovering clean water, hidden contamination sources or helping to design more fuel efficient vehicles and buildings, this center will have applications that will help us all see the future in a very new and exciting way' (BP 2001).

The fully integrated immersive visualization tool enables planning and updating of well paths and platforms in relation to 3D geophysical and geological data. Multi-disciplinary teams can use the 3D visualization technology for field exploration and development planning. Current research projects underway include immersive drilling planning, surface draping and automatic fault interpretation.

Other successful immersive marine visualization has been conducted by NOAA Pacific Marine Environmental Laboratory. They recently reported (Belien & Leenders 2002) that they have developed a virtual reality testbed at NOAA's Pacific Marine Environmental Laboratory to facilitate in the interpretation of their data sets using an ImmersaDesk (Fakespace 2002).

Using the ImmersaDesk enables collaborative stereographic viewing and greatly improves understanding of the complex marine datasets.

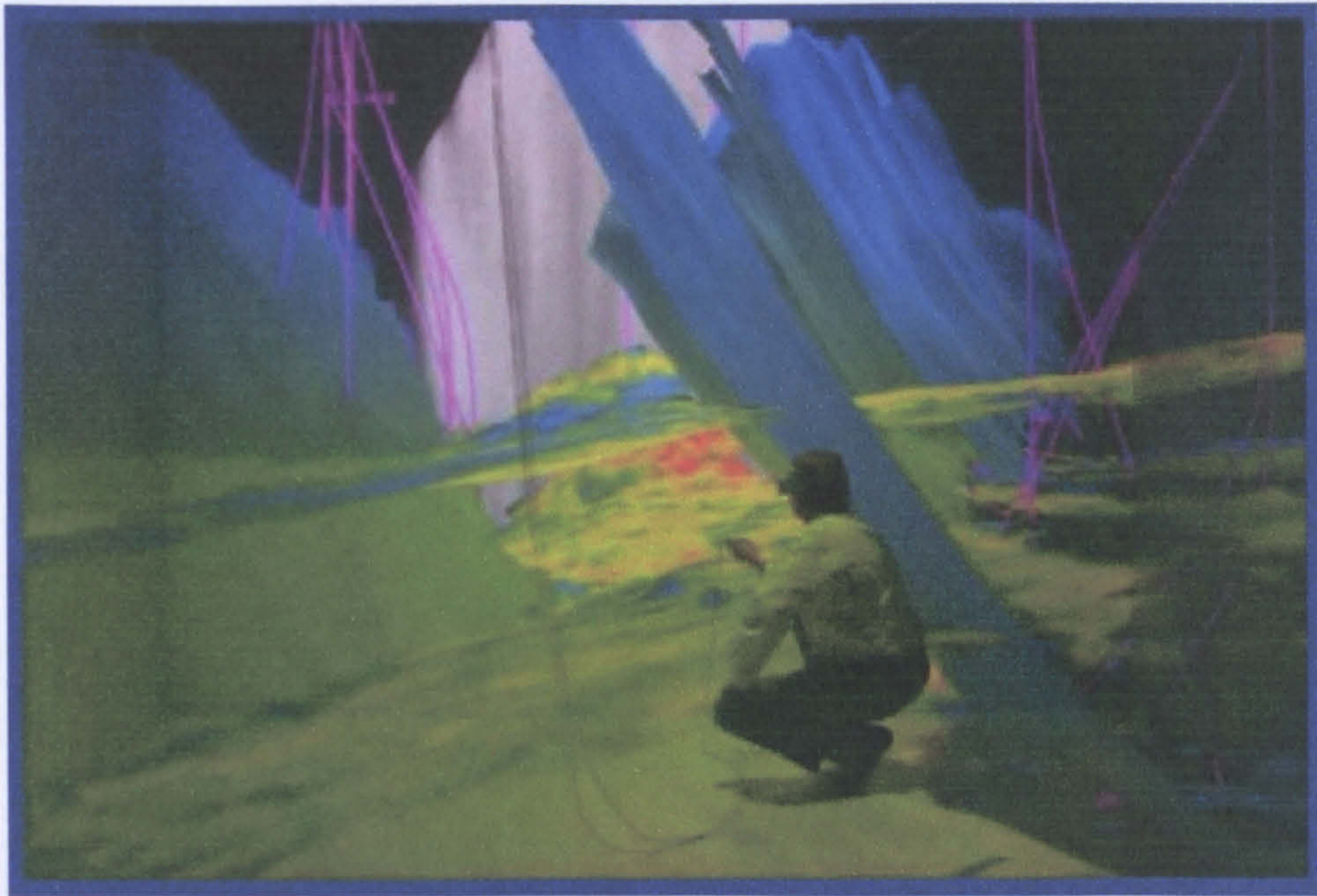

Figure 11.1: BP Centre for Visualization (BP 2001)

11.2.2 Future Immersive Marine Projects: Virtual Great Barrier Reef

A major immersive marine visualization project currently underway is the Virtual Great Barrier Reef immersive DOME installation (Refsland, Ojika, DeFanti, Johnson, Leigh, Loeffler & Tu 1998) currently being developed in a collaborative effort involving Scot Thrane, Takeo Ojika, Tom DeFanti and Carl Loeffler. This project is looking at immersive interaction techniques for presenting complex marine biology data and other reef data to the general public.

Their proposed system will use machine vision to track the visitors as they walk around the environment. Visitors will be able to 'role-play' various types of marine life so that they can experience life within the reef first-hand. The environment will use a HDTV underwater camera system to display the captured real images of the reef onto the DOME system. The display will then be augmented with computer generated artificial life. An artists impression of the proposed system can be seen in Figure 11.2.

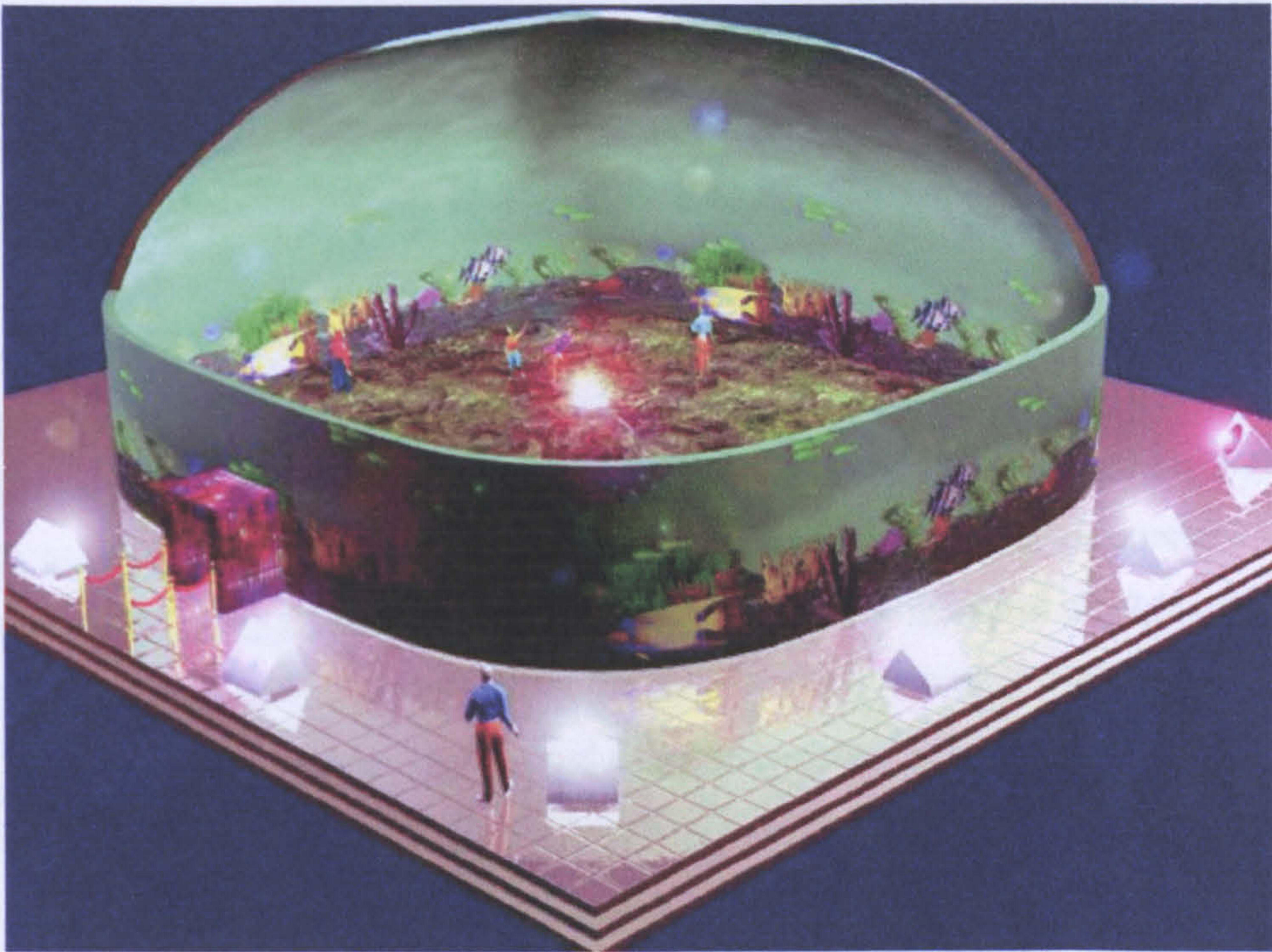

Figure 11.2: Virtual Great Barrier Reef project (Refsland 1998)

11.3 The Practicalities of Real-time Immersive Offshore Visualization

The above examples show how immersive technologies are being used to visualize underwater environments. It is interesting to note however that there are currently no real-time immersive marine visualization displays in use within the offshore industry. Even if such systems were available there would be two major obstacles to their implementation: expensive vessel 'real estate' and the effects of eye fatigue caused by prolonged use of stereo displays.

11.3.1 Vessel 'Real Estate'

Immersive display systems such as the ImmersaDesk require large amounts of space (or 'real estate') that cannot be accommodated on cramped working vessels. Even today's modern offshore working vessels have accommodation problems. Any hardware with large footprints must be absolutely essential to the day to day running of a vessel.

11.3 The Practicalities of Real-time Immersive Offshore Visualization

11.3.2 Stereo Eye Fatigue

Since the 1950s era of 3D movies, stereoscopic displays have often been associated with eye fatigue and headaches. These problems are generally caused by bad alignment of the stereoscopic images. Even with today's improved technology, stereographic displays can still prove to be problematic if good stereoscopic alignment is not maintained. Consequently, stereo glasses are generally only used for short periods of time, for example, a chemist may manipulate a chemical structure in 3D over a 10 minute period. It would not be feasible to port this immersive interface to the offshore industry and suggest that an operator should use flicker glasses or HMD for a complete workshift (typically in excess of 12 hours).

Although stereoscopic views are often associated with eye fatigue and headache problems, there have been some successful trials of stereocameras by ROV pilots in the offshore industry. Research by Woods, Docherty & Koch (1994) has investigated the placement of special stereoscopic cameras carefully positioned on an ROV. The two cameras (positioned in parallel next to each other) send images back to the ROV control cabin which can then be displayed using a special monitor and flicker glasses. These images are not computer generated as each eye is linked directly to the corresponding video camera on the ROV. Woods highlights the importance of accurate stereoscopic alignment for 3D viewing as misaligned stereoscopic displays can bring about migraine, eye fatigue and vomiting. This would be further exaggerated on a pitching vessel in a heavy swell.

Woods states that the major advantage of stereoscopic displays for ROV pilots is the improvement in depth perception for close-quarter manipulator work. For example, using the ROV arms to perform a specific task such as tightening a bolt or tying an underwater strop. One of the advantages of manipulator work is that it can generally be achieved quite quickly and therefore the operator would not have to wear the HMD or flicker glasses for long periods.

As previously stated, stereoscopic displays and projected wall or hemispheric displays are not to be found on working offshore vessels due to cramped working conditions and the headache / nausea problems associated with immersive stereo viewing. The following section considers the possibility of relocating real-time offshore visualizations to an onshore head office.

11.3 The Practicalities of Real-time Immersive Offshore Visualization

11.3.3 Relocating the Real-time Marine Displays

In recent years, operational control has very noticeably moved from the Party Chief on board the working vessel to onshore head offices who give direct orders to the Party Chief and Operations Managers. These new procedures constantly interrupt the Party Chief from the task at hand and were quite noticeable during mining and debris clearance operations such as those highlighted in Chapters 9 and 10.

Subsequent sections consider the possibility of installing an immersive environment onshore at head office. The objective is to provide office and management personnel with real-time visualization and monitoring of offshore activities. This should consequently reduce the amount of communication and interruptions that are directed towards the Party Chief onboard the operations vessel.

Why Immersive Displays?

It could be argued that the onshore visualization of offshore operations would not have to be displayed in an immersive environment. For example, all information and rendering could be viewed using a single desktop computer and monitor. While this is feasible, it should also be noted that a number of decisions made in the industry are collaborative decisions and consequently sharing the information and views with the decision makers without having to crowd around a single monitor or talk on the phone using different displays (and therefore possibly ambiguous datasets) could be extremely advantageous. Collaborative visualization of marine data would be possible using immersive displays such as the Elumens hemisphere display or large wall projector displays.

The following sections consider the possibility of streaming operational data from the vessel back to headquarters providing the onshore management team with an immersive 'state of operations' which could also reduce verbal communication between the two parties freeing up the Party Chief from onshore interruptions and providing more accurate information to head office. A feasibility study into remote control or 'tele-operations' of offshore procedures is also considered in Section 11.6.

11.4 Augmenting the WFM View Architecture to Accommodate Stereo and Fisheye Distortion

Before any immersive scenarios are considered, the WFM architecture must be augmented to provide stereoscopic views and hemisphere fisheye distortion.

11.4.1 Generating Stereo Views

Section 11.1.1 described the basic theory behind stereoscopic views. WFM can produce stereoscopic displays by creating two display buffers, one for each eye. A typical procedure for generating a stereoscopic display is as follows:

1. Set the geometry for the left eye.
2. Set the left eye display buffers.
3. Render the left eye image.
4. Set the geometry for the right eye.
5. Set the right eye display buffers.
6. Render the right eye image.
7. Swap the display buffers.

Lipton & Halnon (1998) provides the necessary mathematics required for generating effective stereoscopic displays and correct positioning of cameras.

11.4.2 Generating Fisheye Views

Section 11.1.3 described how distortions are required for correct rendering to hemispheric displays such as the Elumens VisionStation (Elumens 2002a). Bourke (2002) also provides information dedicated to hemispherical and lens distortion projections. The preferred technique (and the one adopted) was to use the Elumens's SDK (Elumens 2001).

11.4 Augmenting the WFM View Architecture to Accommodate Stereo and Fisheye Distortion

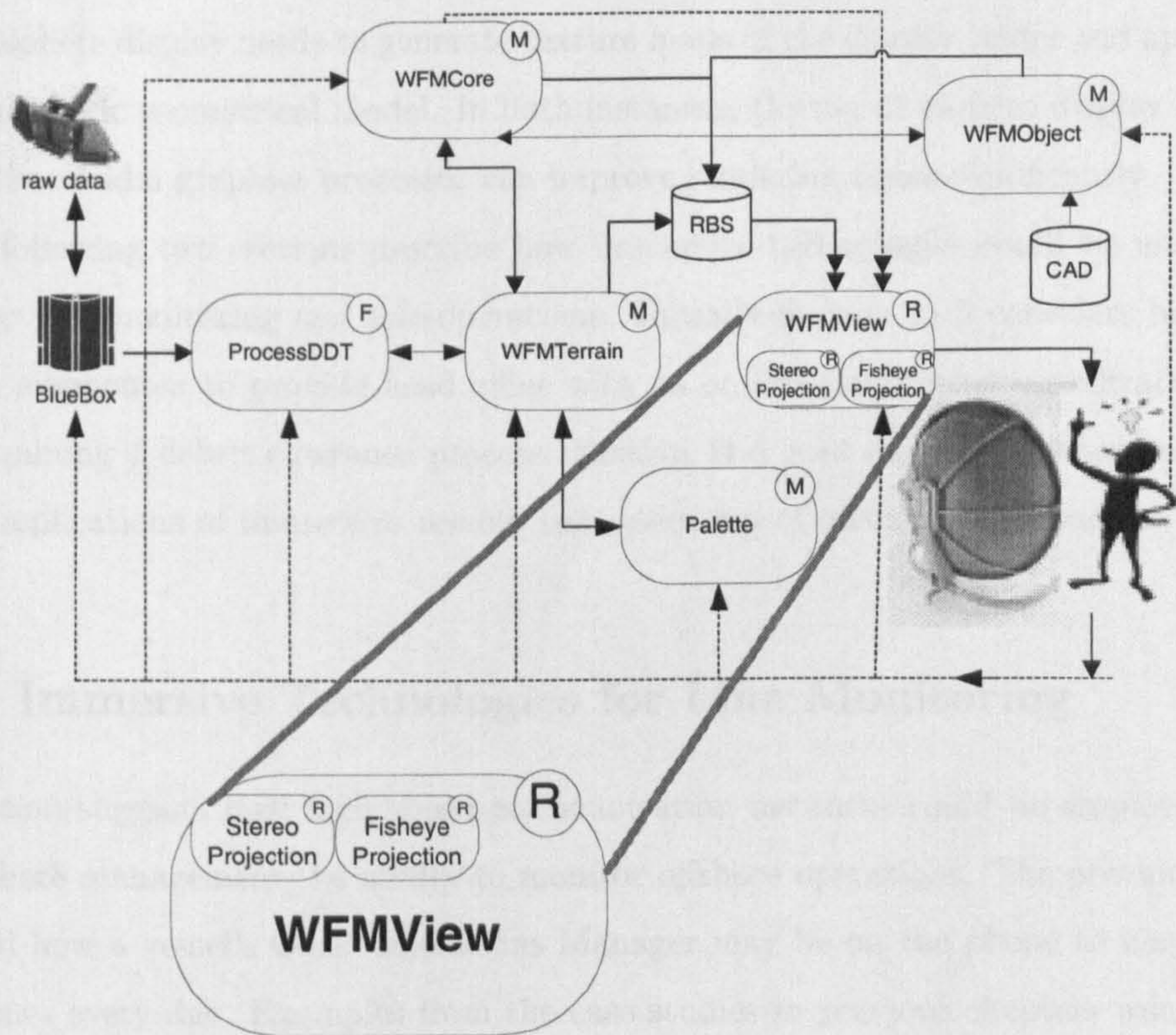

Figure 11.3: WFM architecture implementing stereoscopic and hemispheric projections

11.5 Immersive Technologies for Line Monitoring

11.4.3 Immersive WFM Architecture

Figure 11.3 shows a simple WFM marine visualization architecture that has been augmented to permit stereoscopic and hemispheric output of the 3D view. The WFMView module has two new internal routines: 'Stereo Projection' and 'FishEye Projection', these can be toggled on and off by the user. Both display techniques will reduce the final rendering rate because the system has significantly more processing to generate any given frame of animation. For example, the stereo display now needs to generate a view for each eye and the hemisphere display needs to generate texture maps of the display buffer and apply them to a hemispheric geometrical model. In both instances, the use of modern display hardware such as the nVidia graphics processor can improve rendering times significantly.

The following two sections describe how immersive technologies could be used within WFM for line monitoring and tele-operations. Initially Section 11.5 considers how WFM could be augmented to provide head office with an on-line monitoring visualization of the offshore mining / debris clearance process. Section 11.6 goes one step further and considers the implications of immersive remote tele-operation of offshore tasks such as diamond mining.

11.5 Immersive Technologies for Line Monitoring

This section suggests how high speed communication networks could be employed to enable onshore management the ability to monitor offshore operations. The previous section described how a vessel's Chief Operations Manager may be on the phone to his superiors many times every day. Examples from the case studies in previous chapters would be the debris clearance and diamond mining operations (Chapters 9 and 10 respectively).

If a remote party (the offshore party) shared operation specific data with the land based head office, then it would be feasible to generate a WFM Remote view that rendered the offshore WFM RealiBase containing the real-time 3D scene geometry. Sharing the RealiBase would provide onshore head office with a very dynamic real-time visualization of offshore operations. The line monitoring tool could also be used for visualizing specific operational 'states'.

11.5 Immersive Technologies for Line Monitoring

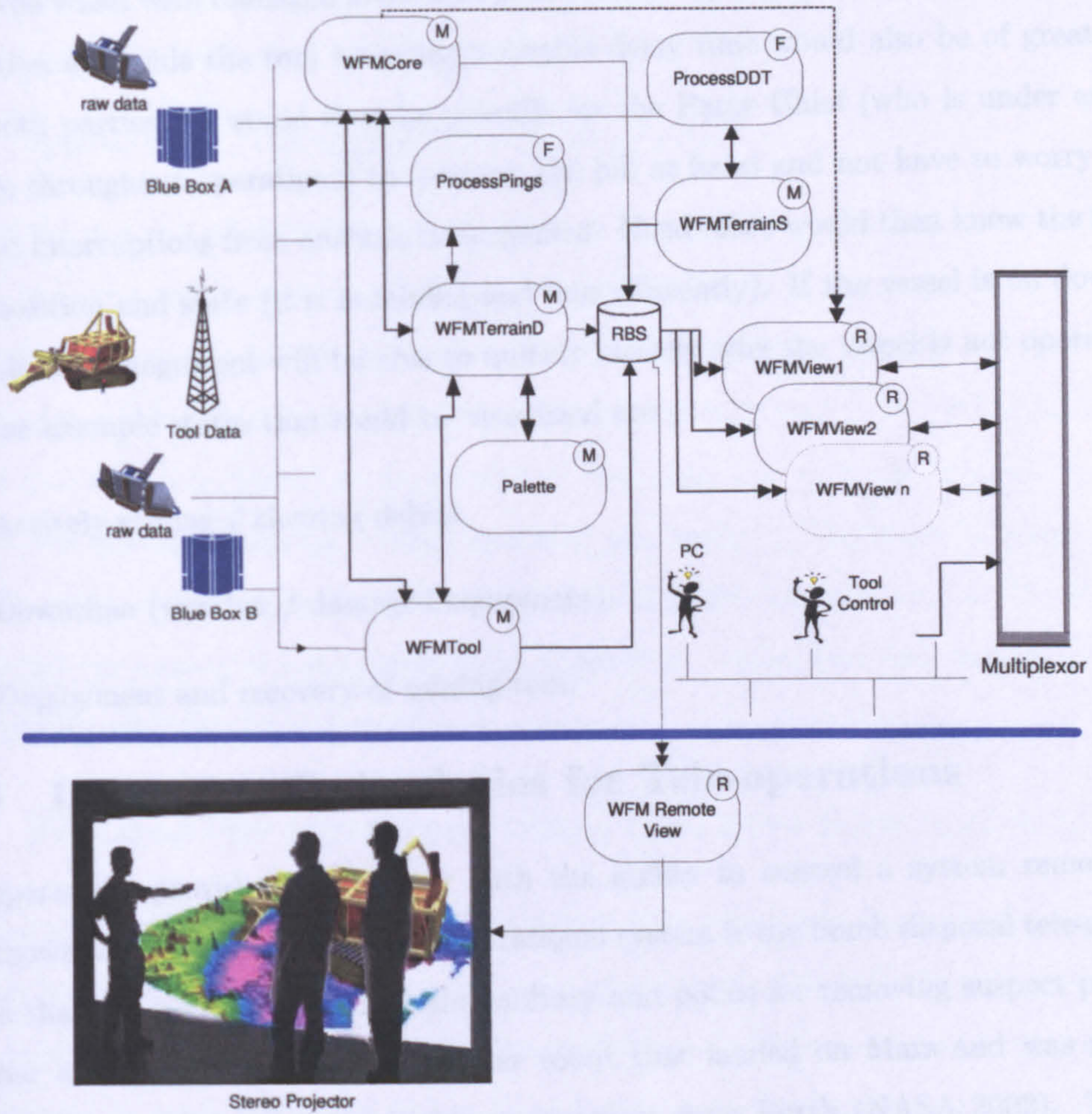

Figure 11.4: Proposed architecture for remote offshore visualization and monitoring

11.6 Immersive Technologies for Tele-operations

11.5.1 Visualizing Offshore States

Specific visualizations or mini recursive animations could be used to symbolise associated states of operability. For example, if the diamond mining tool (Chapter 10) was not operational due to damage incurred from the last working dive then the WFM view sent to the bridge (and to central office) could be a semi transparent rotating mining tool on the bow of the vessel with damaged areas and points under repair highlighted. A short textural description alongside the tool including probable delay time would also be of great benefit to both parties. It would then be possible for the Party Chief (who is under extreme pressure throughout operations) to focus on the job at hand and not have to worry about constant interruptions from onshore management. Head office would then know the mining tool's position and state (if it is mining and how efficiently). If the vessel is on downtime the onshore management will be able to quickly identify why the vessel is not operational.

Some example states that could be visualized are:

1. Actively mining / clearing debris.
2. Downtime (weather / damaged equipment).
3. Deployment and recovery of mining tool.

11.6 Immersive Technologies for Tele-operations

Tele-operations provide the operator with the ability to control a system remotely. A well known and much publicised tele-operational system is the bomb disposal tele-operated robots that are frequently used by the military and police for removing suspect packages. Another example is the Rover Sojourner robot that landed on Mars and was remotely controlled by a pilot in an immersive environment from Earth (NASA 2002). This section considers the issues relating to controlling a mining vessel remotely using immersive technology from onshore offices. The advantages of such a system would be the efficient distribution of a pilot's skills and resources around a small mining fleet².

²A pilot is not mining 24 hours a day yet because of the nature of the offshore industry, he is required to stay on board for the entire duration. A small fleet may consist of three diamond vessels and they are not necessarily all mining at the same time. For example, one may be travelling, one mining and one on downtime.

11.7 Post-survey (non-real-time) Onshore Immersive Displays

The dataflow architecture for such a system would be very similar to the previous example except that now the system must be augmented to allow for user input and control signals back to the mining vessel.

Figure 11.5 shows the WFM architecture that could be employed for tele-operations offshore. As well as sharing the RealiBase, controls need to be sent back to the mother ship. Full duplex audio feedback would be essential for the pilot in order to interact with the second (and remote) pilot.

11.6.1 Immersive Tele-operations In Practice

In theory the concept of remote tele-operations is technically possible, in practice however it would not be feasible and would be extremely dangerous to implement. The offshore mining environment on board any working vessel is extremely complex. Removing the pilot from the synergetic hub of activity would mean they would be devoid of hundreds of feedback channels that would be impossible to transmit and communicate to the remote operator. For example, hearing a winch straining and failing or the body language of other work colleagues. Although it would be possible to provide the pilot with all the computer displays that are located in the control cabin, these other 'undocumented' feedback channels would only be available on the vessel.

11.7 Post-survey (non-real-time) Onshore Immersive Displays

The two examples of line monitoring and tele-operations described above both assume real-time links between head-office and the offshore operations vessel. Immersive technology can also be used effectively at head office in order to interact and interpret data that has already been collected in much the same way as NOAA are using the stereographic workbench to interpret datasets from El Niño (Belien & Leenders 2002).

Immersive technologies like the hemispheric display, and stereographic displays would be ideal for examining large datasets of bathymetric and pipeline data. The use of stereographic displays would be best suited to viewing pipeline exposure points (Chapter 8) as the 3D objects of interest, the pipelines, are in close proximity to the viewer.

11.7 Post-survey (non-real-time) Onshore Immersive Displays

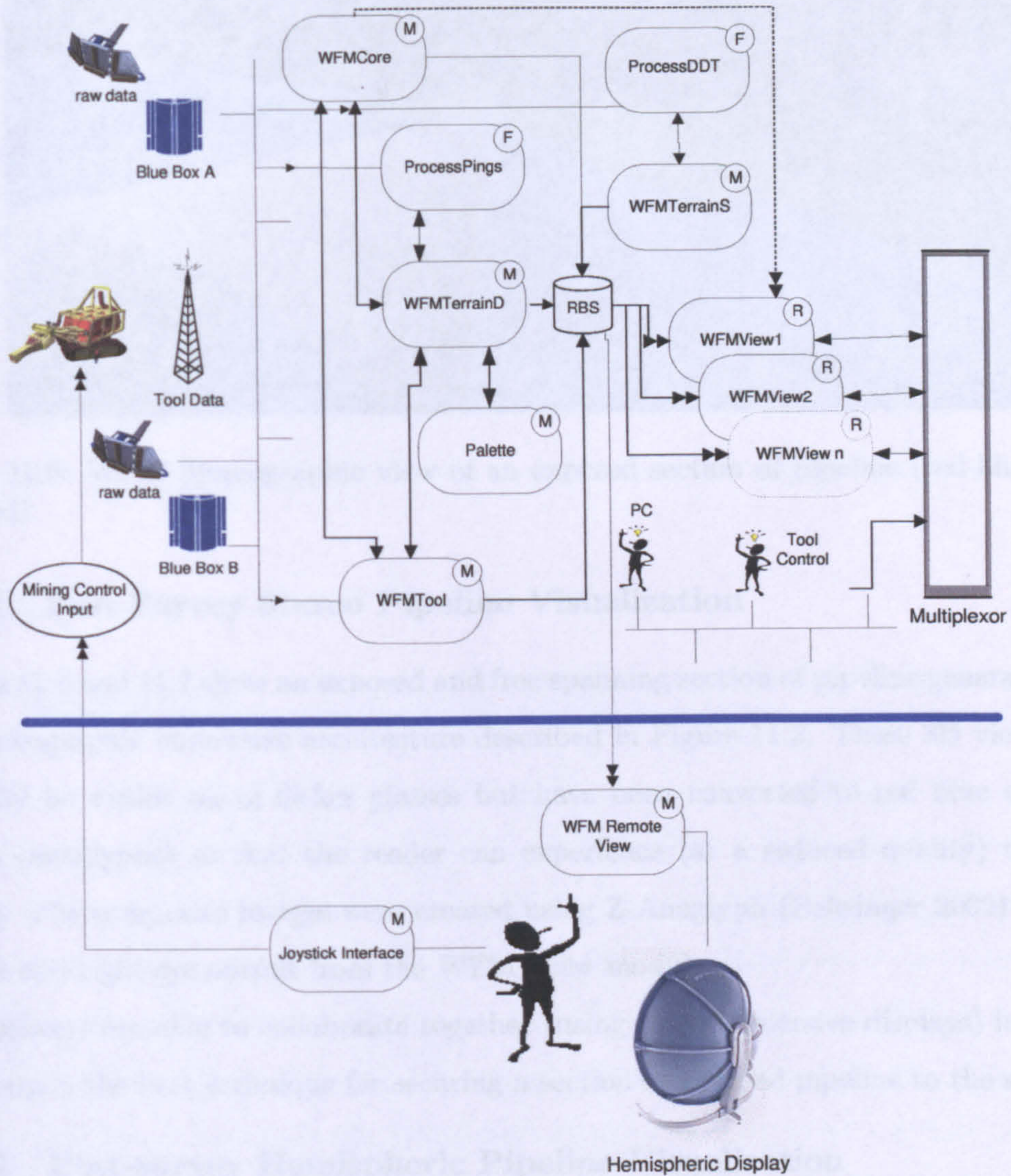

Figure 11.5: Proposed architecture for tele-operation offshore visualization and monitoring

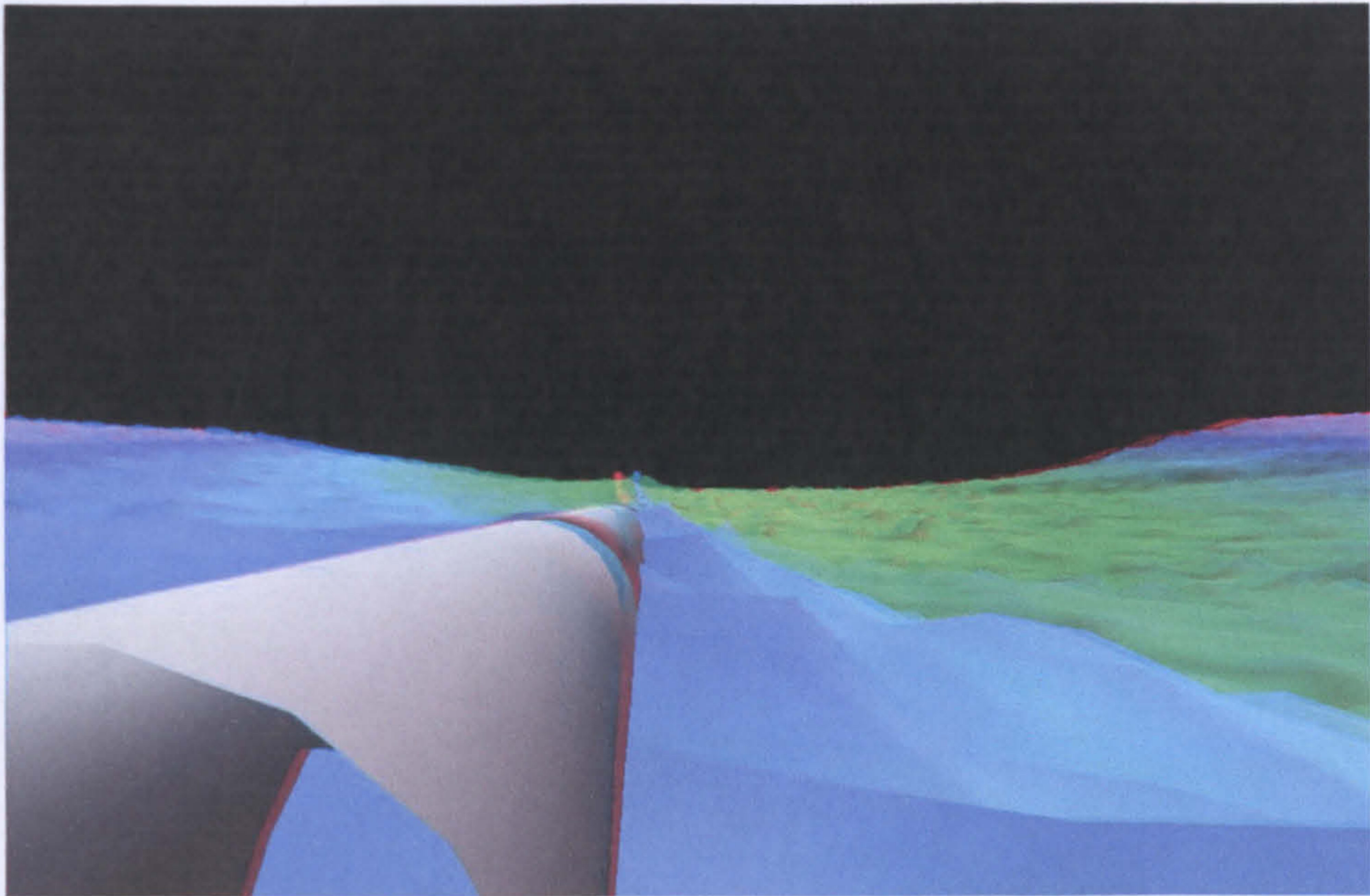

Figure 11.6: WFM Stereographic view of an exposed section of pipeline (red-blue glasses required)

11.7.1 Post Survey Stereo Pipeline Visualization

Figures 11.6 and 11.7 show an exposed and free spanning section of pipeline generated using the stereographic immersive architecture described in Figure 11.3. These 3D views would normally be visible using flicker glasses but have been converted to red blue composite images (anaglyphs) so that the reader can experience (at a reduced quality) the stereo images. The composite images were created using Z-Anaglyph (Behringer 2002) based on the left and right eye output from the WFM View module.

Engineers are able to collaborate together (using these immersive displays) in order to decide upon the best technique for securing a section of exposed pipeline to the seabed.

11.7.2 Post-survey Hemispheric Pipeline Visualization

Figures 11.8 and 11.9 show the effect of distorting a planar image prior to its projection onto a hemispheric surface. The images were created by WFM using the new WFM architecture described in Figure 11.3.

The geometrical mesh that represents the hemisphere display can be seen as the red wire mesh in Figure 11.8. It is this geometry that is texture mapped with the pre-calculated

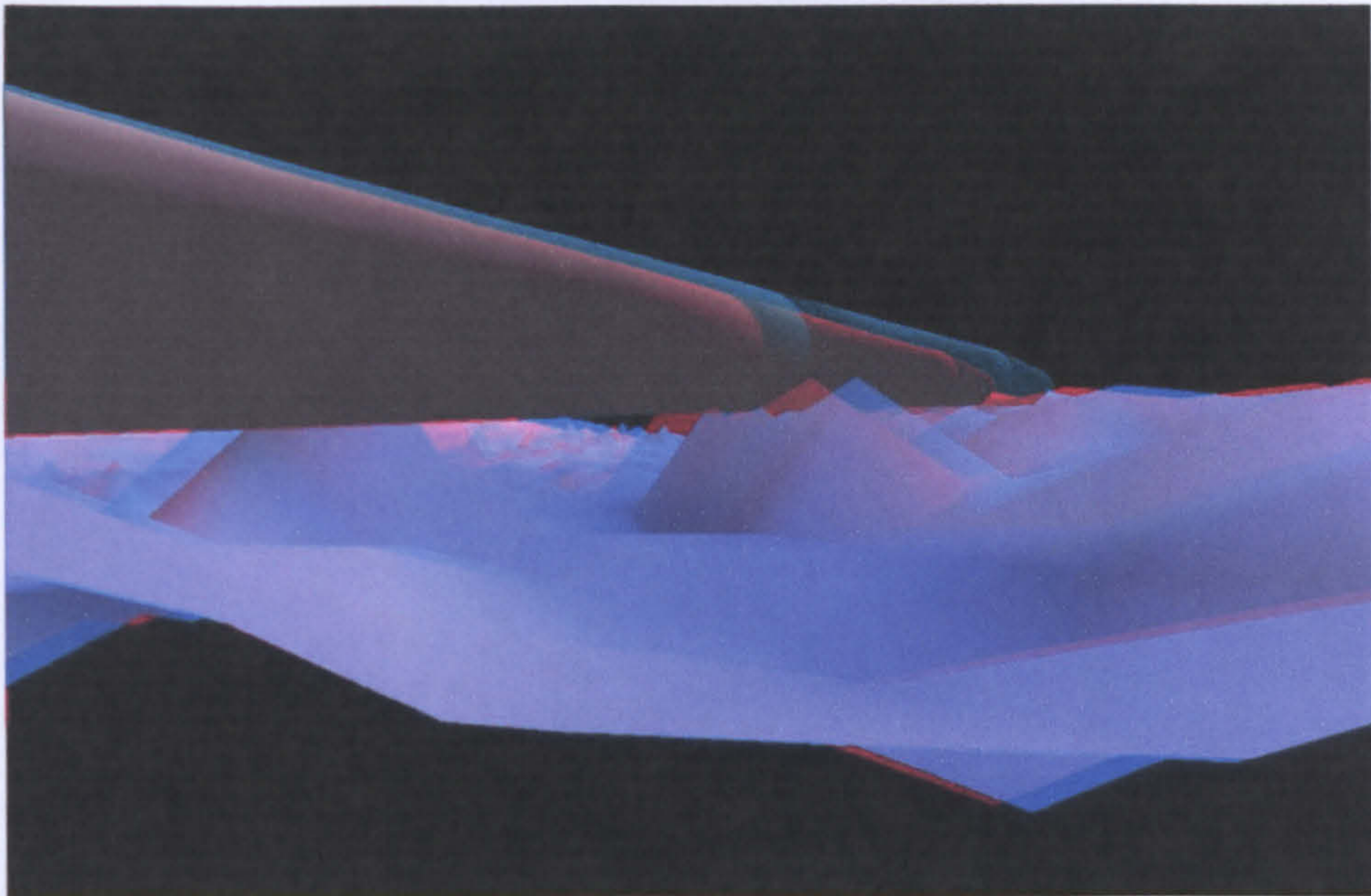

Figure 11.7: WFM Stereographic view of a free-spanning section of pipeline (red-blue glasses required)

display buffer.

11.8 Summary

This chapter has considered how immersive technology can be used to improve our understanding and interpretation of data collected offshore. Data may be visualized in real-time (during a survey) or as a post-survey visualization of pre-collected bathymetric data.

Immersive visualization is being used successfully by a number of companies for visualizing marine related data. Both as a scientific exploratory tool (Belien & Leenders 2002) (BP 2001) and as an educational tool (Refsland et al. 1998). It was noted that immersive displays are not currently being used onboard working vessels within the offshore industry due to space constraints and the inability to provide HMDs that can be worn for long periods of time (such as a 12 hour shift) without making the user feel nauseated. Non-computer-generated stereographic ROV video displays are currently being investigated but the interaction time is limited to minor operations such as manipulator work that can generally be completed within 10 minutes.

Two scenarios were suggested that would enable onshore management to visualize and

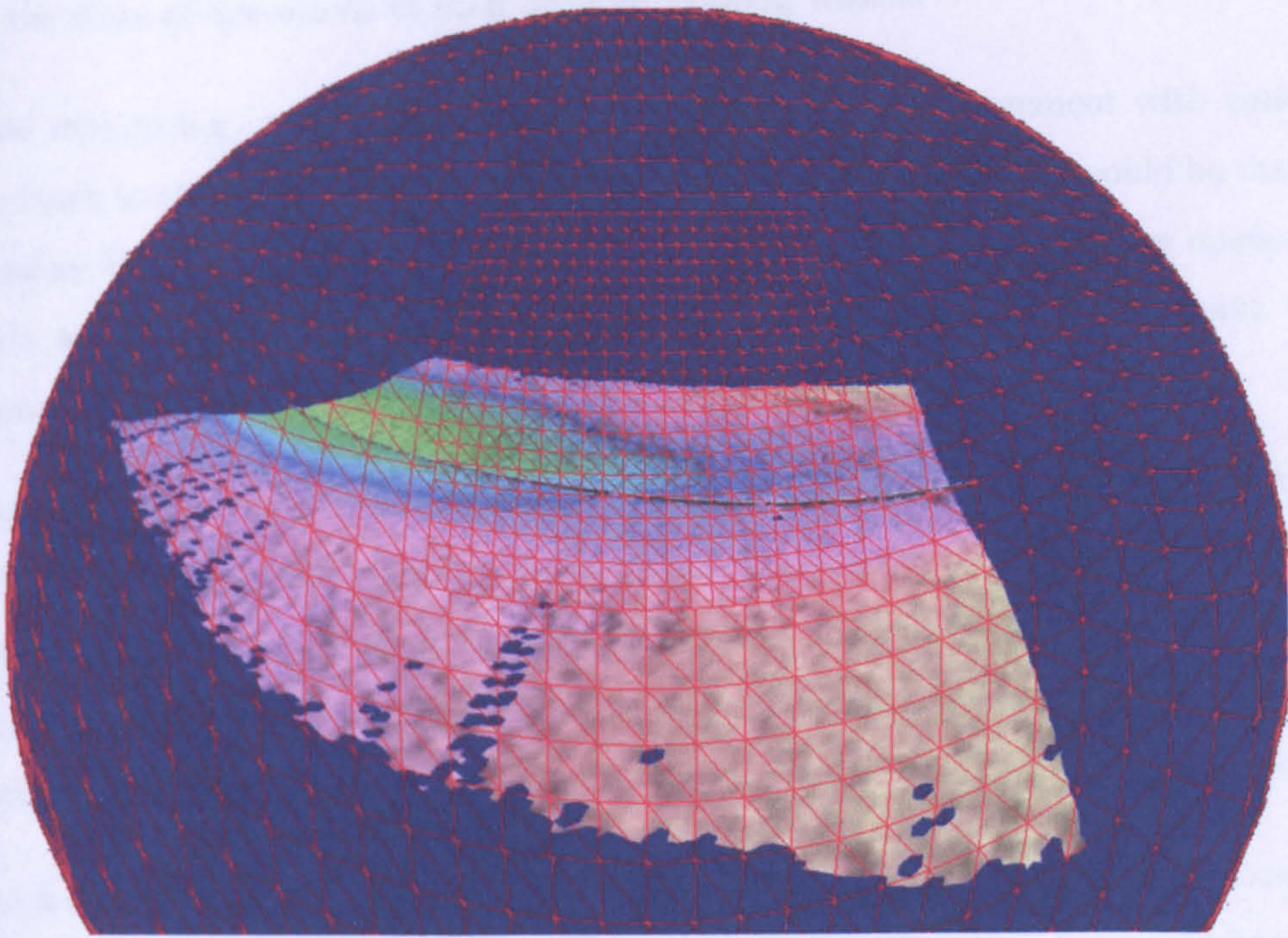

Figure 11.8: WFM Hemispheric pipeline projection including wireframe hemisphere mesh

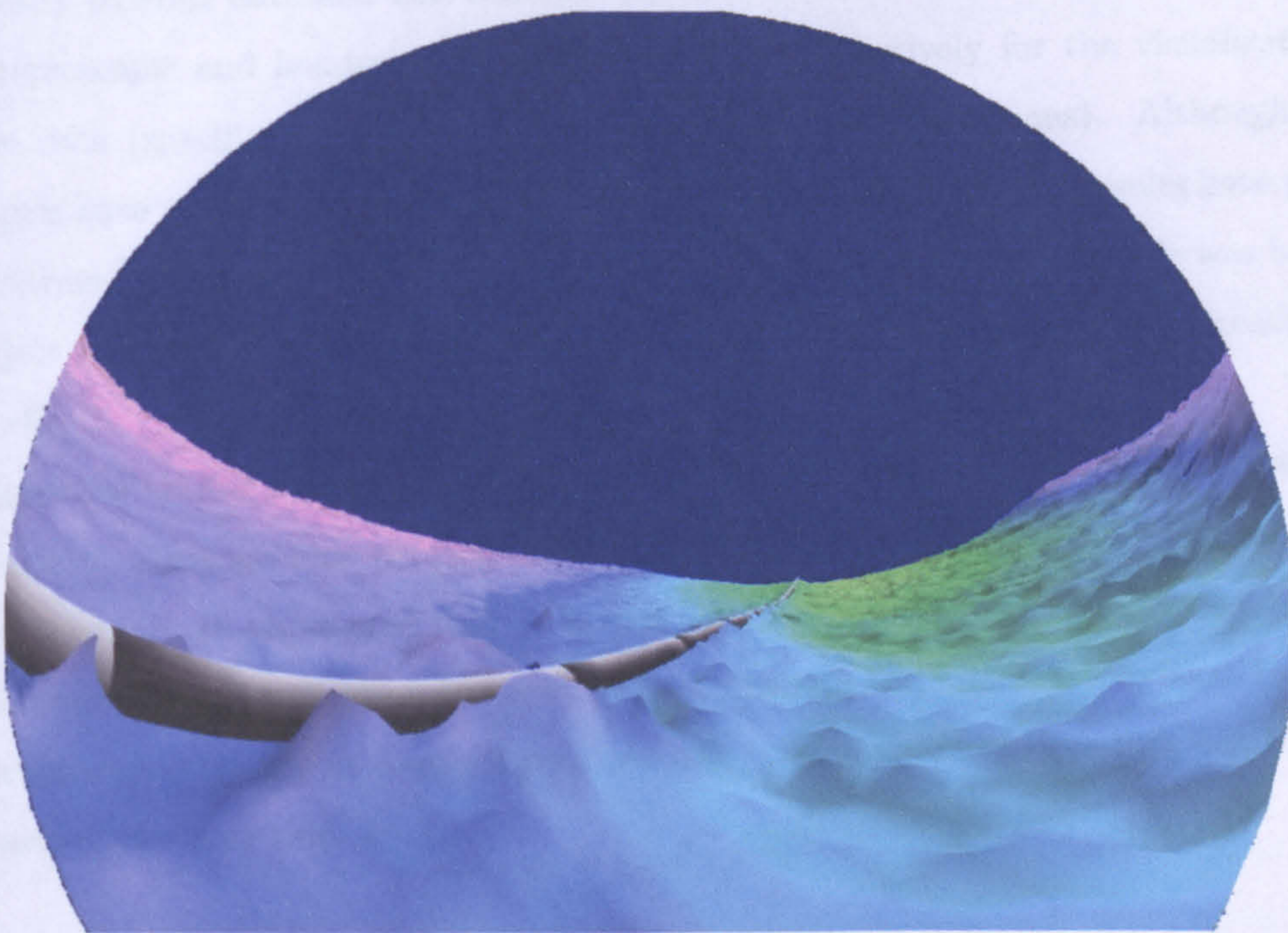

Figure 11.9: WFM Hemispheric pipeline projection

11.8 Summary

monitor the state of operations of their offshore working vessels:

1. Line monitoring was considered to provide the onshore management with constant feedback to offshore operations. The main advantage of this system would be that the onshore management would have a real-time updated model of offshore operations. This would result in reduced communication and interruptions to the Party Chief from onshore management.
2. Tele-operations were considered as a method for immersing an operator such as a diamond mining pilot remotely (away from the working vessel) in order to better distribute his skills to other vessels. This was decided to be impractical due to the large number of feedback channels that could not be communicated from the working vessel to the remote pilot.

NOAA and BP have proved how immersive displays can be used effectively for visualizing sea surface temperature and seismic data sets respectively. The same immersive hardware and display technologies can equally be used to visualize data such as bathymetric and underwater pipeline data and this concept was considered in Section 11.7. In this section, both stereoscopic and hemispheric displays were used effectively for the visualization of pipeline data (specifically exposed and free-spanning pipeline sections). Although these techniques have yet to be validated in the offshore industry, preliminary results have proved to be extremely promising. One of the reasons the stereo view was so effective was because the object of interest (the exposed section of pipeline), is close to the viewer increasing the stereo effect.

Immersive marine systems have yet to play an important role in the visualization of marine data. Stereographic projectors, worktops and VR interfaces along with other new technologies such as augmented reality (Rosset 2002) will no doubt eventually be integrated into future marine visualization systems for both onshore and offshore activities. However, significant improvements in stereo display technology are required before they can be safely implemented for long shift work.

Chapter 12

Conclusions and Future Work

This chapter reviews the contributions that this thesis has made to the offshore marine industry and academic communities. Initially Section 12.1 reviews the aims and objectives of the thesis as outlined in Chapter 1. A review of WFM's architecture is described in Section 12.2 together with a methodology for extending the architecture. Section 12.3 describes how WFM visualizations reduce interpretation delays of real-world abstractions and also describes how 'ingrained user models' developed by offshore personnel after years of working with a particular interface can be hard to change.

Section 12.4 briefly describes five areas of future offshore marine research that have been realised as a result of work carried out in this thesis.

12.1 Review of Aims and Objectives

The aim of this thesis has been to research and demonstrate the effectiveness of 3D computer graphics environments for visualizing offshore marine activities and collected data, at both a planning pre/post-survey level and for real-time situation awareness.

Chapter 1 initially identified five objectives that were deemed to be important for achieving this aim.

1. To investigate current marine visualization techniques and methods in order to determine the current state of today's marine visualization technology.
2. To describe the development and implementation of a 3D marine visualization methodology that addresses the limitations and deficiencies of contemporary marine systems described in item 1.

12.1 Review of Aims and Objectives

3. To verify the practicality and effectiveness of the developed marine visualization system through a wide range of case studies that apply the system to diverse real offshore scenarios.
4. To conduct a feasibility study into the use of stereoscopic displays and other immersive VR technologies for visualizing and interacting with offshore marine data.
5. To research and report on any psychological end-user observations relating to items 3 and 4.

The objectives outlined above have all been met and a summary of the work achieved is described below.

Chapter 4 provided an extensive investigation into visualization tools that are currently available to the offshore engineer for the visual interpretation of collected marine data. By carefully examining contemporary marine visualization systems and from experience in the field, it became evident that very few systems were taking advantage of recent advancements in graphics processor technology. The review of marine visualization systems revealed that no single marine visualization system had experimented with offshore activity environment modelling or the generation of accurate 3D offshore activities using multiple data sources. It was found that these systems generally focus on a single data set (usually of a bathymetric nature) but little or no research had investigated the possible benefits to the end-user of full environmental marine modelling. Through careful analysis of the offshore industry and by evaluating contemporary marine visualization systems against a set of desirable offshore characteristics, a Whole Field Modelling System was proposed that was based on the shortfalls of existing systems and 3D environment modelling (described above).

The development, offshore implementation and end-user observations of the WFM marine visualization system became the main research drive of this thesis.

WFM was developed using Microsoft's Visual C++ (White et al. 1999) and DataPath's RealiMation graphics SDK (DataPath 2001). One of the primary goals for WFM was to provide a 3D visualization of entire offshore procedures and activities within a single 3D graphics display. These visualizations were generated using numerous secondary data sources that were all indirectly linked to the offshore activity. This novel holistic approach allowed new visualizations of existing offshore activities to be investigated.

12.2 WFM Architecture Review

The practicality and effectiveness of the WFM marine visualization system was tested through a wide range of offshore activities that increased in complexity. Five offshore scenarios were thoroughly investigated: shipwreck, harbour wall, pipeline, debris cleanup and diamond mining visualization. During these trials, a number of 'firsts' were made in object registration, real-time marine visualization, real-time per-ping updates of 3D bathymetry, and effective capture and visualization of multiple datasets. Each of the case studies augmented and tested new areas of the WFM system and architecture.

A feasibility study into the use of stereographic and other immersive displays was conducted in Chapter 11. The findings suggested that stereographic immersive implementation would not be beneficial in an offshore working environment. Results of onshore immersive post-survey / real-time visualization of marine data however proved to be more promising. Immersive stereo post-survey visualizations of pipeline data proved to be especially effective at examining areas of interest such as pipeline exposure and free-span pipe sections.

12.2 WFM Architecture Review

This thesis has described the incremental development of a MVE architecture for the development, implementation and research into novel 3D marine visualizations. In order to summarise and bring together all the architectures from the previous case studies, a pseudo case study is proposed that incorporates elements of all the case studies described in the previous chapters.

This complex theoretical offshore activity involves the visualization of a pipeline dredging process within a deep harbour inshore environment. The visualization would encapsulate the real-time visualization of a dredger on the harbour floor (including real-time seabed terrain updates) with two dynamically tracked ROVs and a dynamically positioned control barge, a large section of underwater pipeline (automatically imported from a pipe information file), harbour wall, support for multiple data sets (such as ROV video footage and SBP images) and multiple views (which may be viewed remotely). These displays may be viewed in an immersive environment (either as a hemisphere display or stereo projected).

In reality, it is unlikely that an offshore activity of this complexity would be operating with all tasks simultaneously. Rather the activities would be distributed into different tasks

12.2 WFM Architecture Review

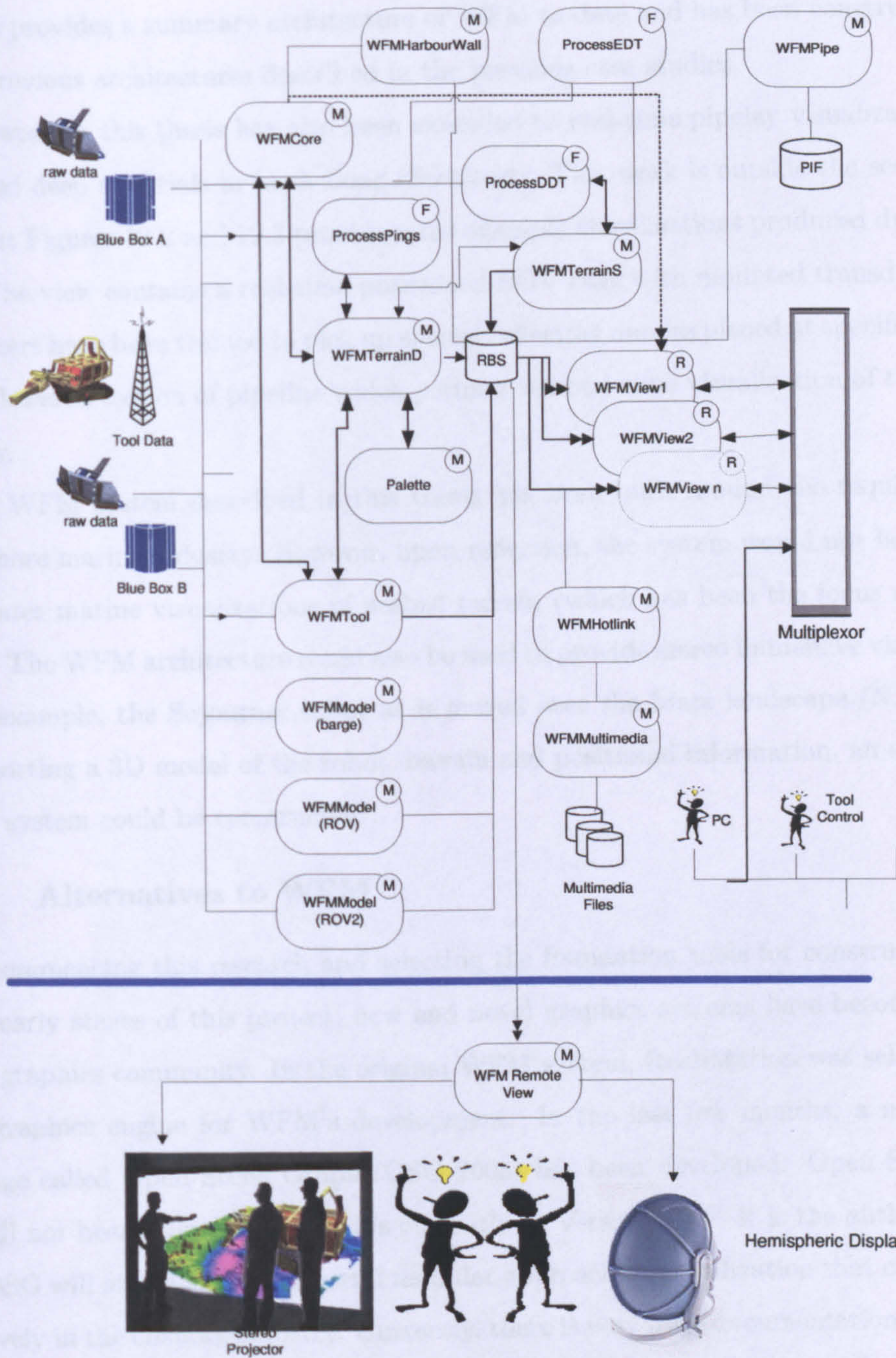

Figure 12.1: WFM Version 1.0

12.2 WFM Architecture Review

that would be run consecutively to reduce the risk of inter-task interference. However it would be feasible for WFM to visualize offshore activities of this complexity. Figure 12.1 therefore provides a summary architecture of WFM to-date and has been constructed from all the previous architectures described in the previous case studies.

The work in this thesis has also been extended to real-time pipelay visualizations with associated deep sea trials in Loch Long (Scotland). This work is outside the scope of this thesis but Figures 12.2 and 12.3 provide some example visualizations produced during these trials. The view contains a real-time positioned ROV cage with mounted transducers. The transducers have been trained to pick up special reflecting anodes placed at specific positions along a lowered section of pipeline which permits the real-time visualization of the pipeline catenary.

The WFM system described in this thesis has been built around the requirements of the offshore marine industry. However, upon reflection, the system would not be limited to underwater marine visualizations of seabed terrain (which has been the focus area of this thesis). The WFM architecture could also be used to provide stereo immersive visualizations of, for example, the Sojourner robot as it moved over the Mars landscape (NASA 2002). By importing a 3D model of the robot, terrain and positional information, an accurate 3D control system could be constructed¹.

12.2.1 Alternatives to WFM

Since commencing this research and selecting the foundation tools for constructing WFM in the early stages of this project, new and novel graphics systems have become available to the graphics community. In the original WFM system, RealiMation was selected as the main graphics engine for WFM's development. In the last few months, a new graphics language called Open Scene Graph (OSG 2003) has been developed. Open Scene Graph has still not been fully released and is currently at Version 0.9.6. It is the author's opinion that OSG will offer a similar powerful modular approach to visualization that could be used effectively in the offshore industry. Currently, there is very little documentation on the OSG graphics library and experience is gained from examining sample projects. However, a book

¹Although real-time WFM displays of the Sojourner robot would suffer from communication delays which are inevitable when communicating with a computer system 78.3 million kilometers away.

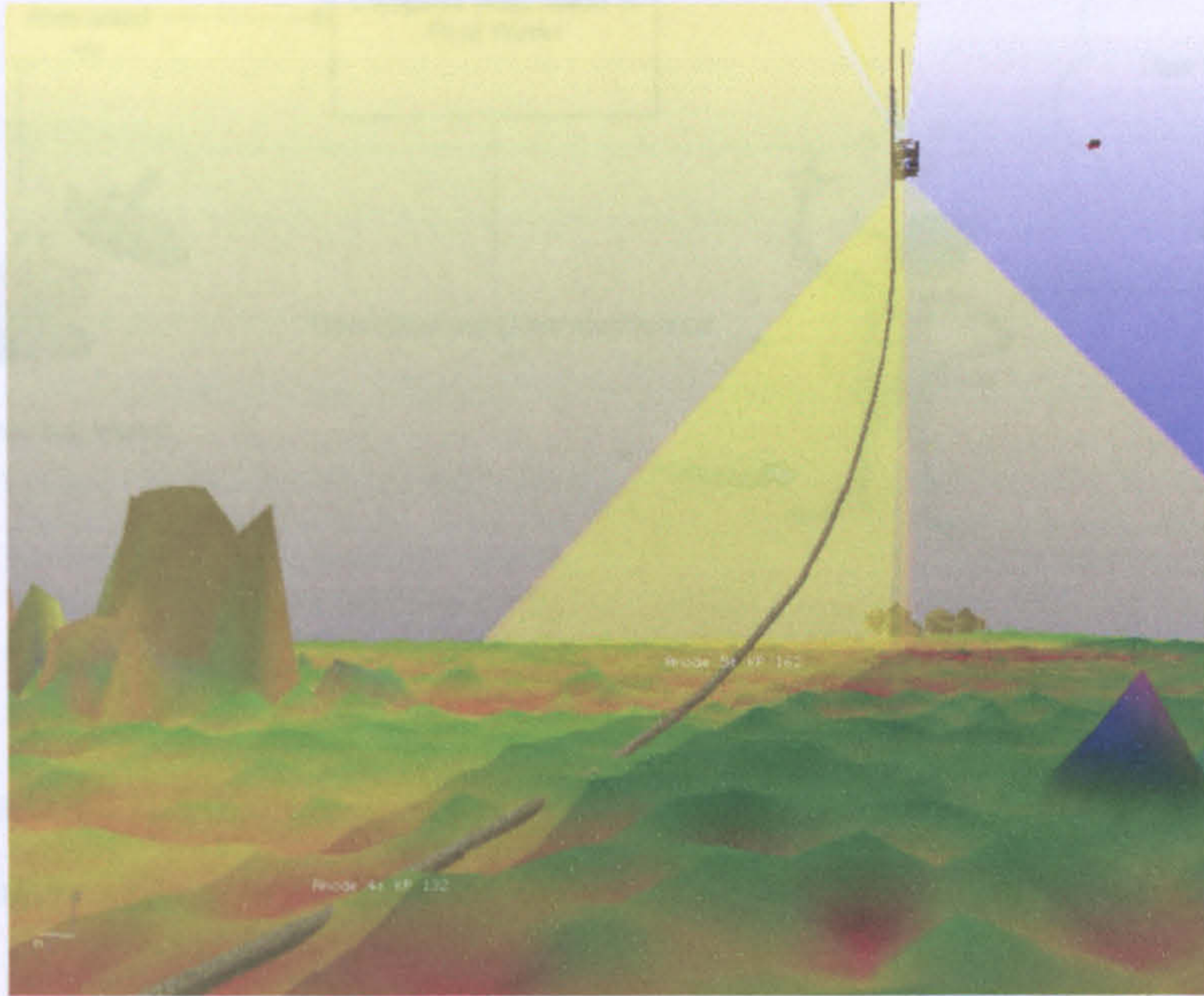

Figure 12.2: Real-time Pipelay Visualization

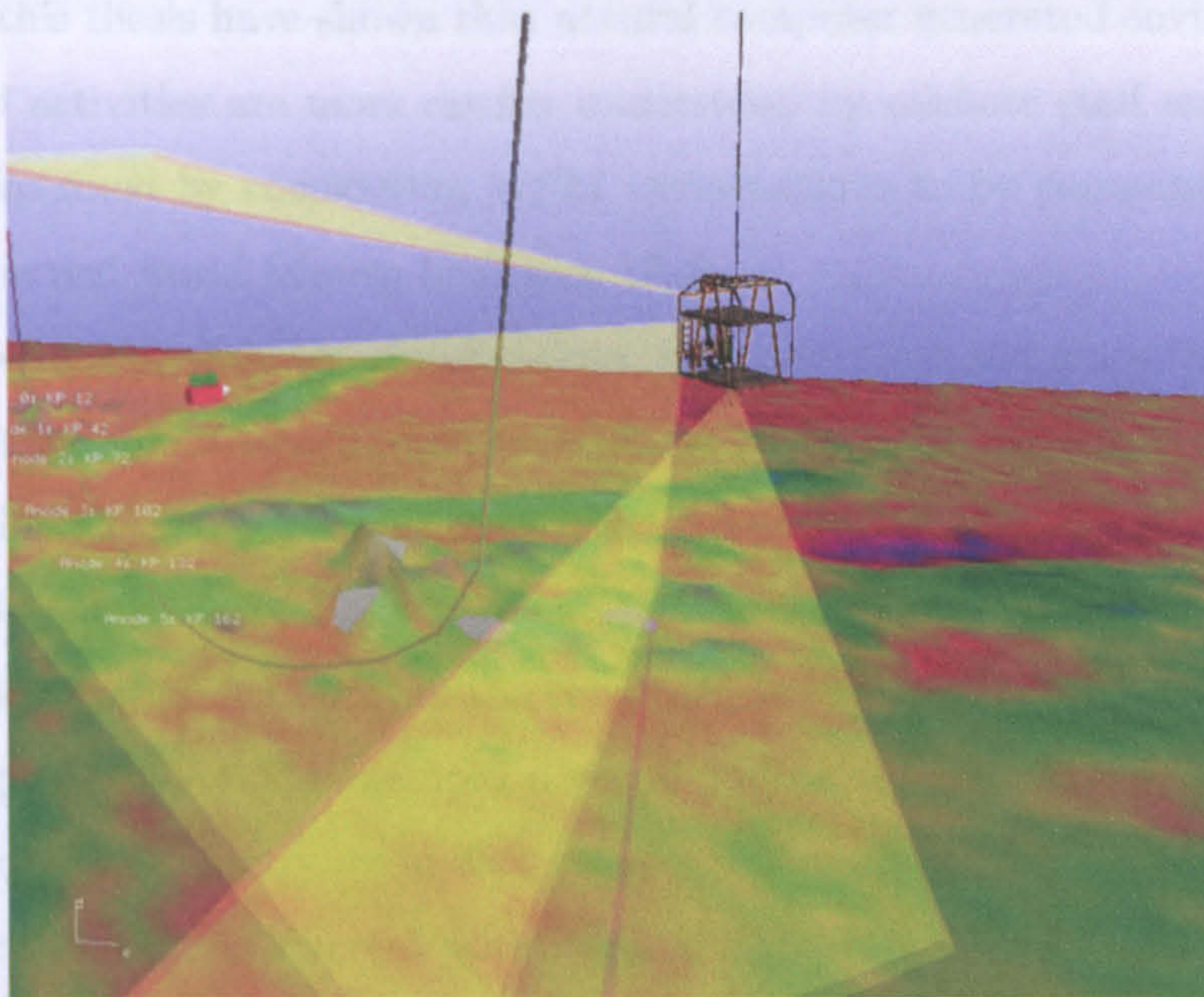

Figure 12.3: Real-time Pipelay Visualization

12.3 Reducing User Interpretive Delays with WFM Visualizations

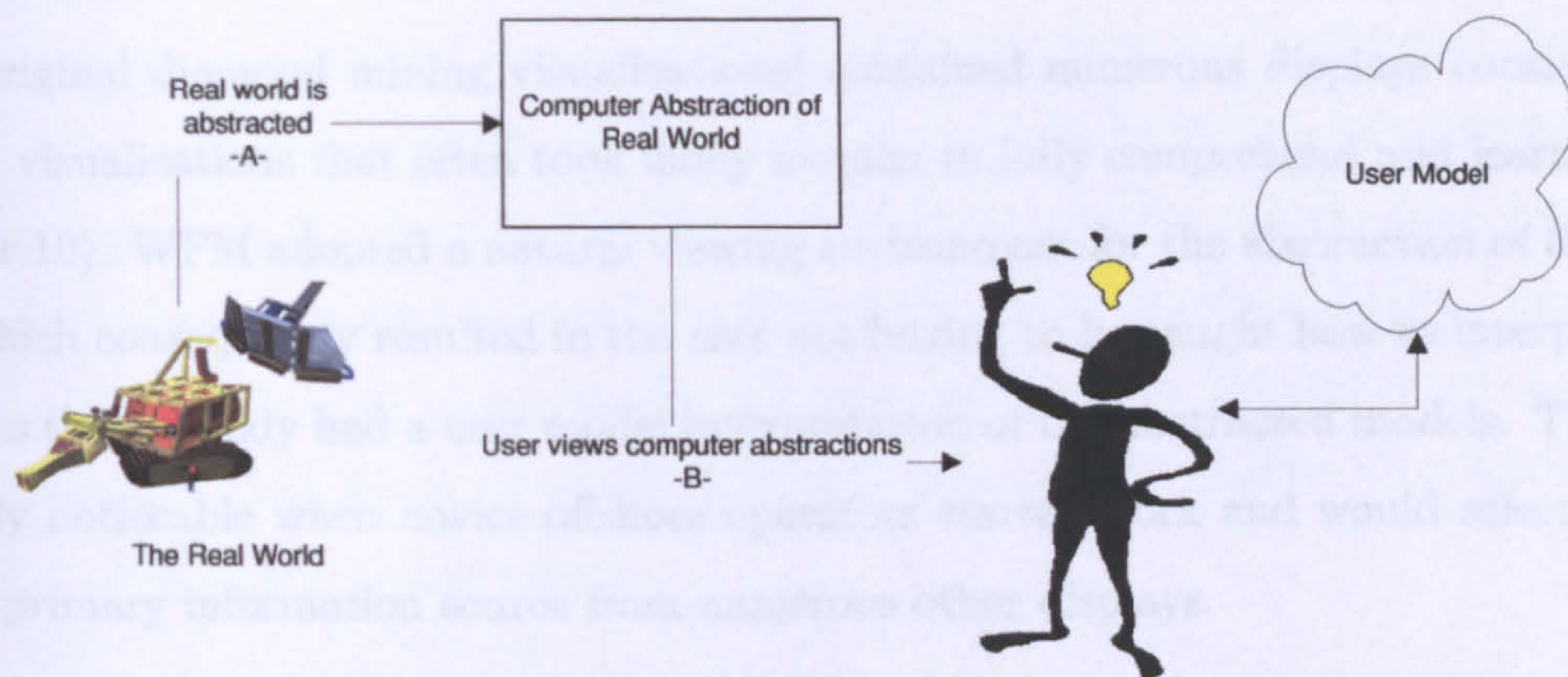

Figure 12.4: Reality and the user model

by the primary OSG developers is expected in the not too distant future and it is expected that this language will grow to become an extremely popular and successful development language.

12.3 Reducing User Interpretive Delays with WFM Visualizations

The results of this thesis have shown that natural computer generated environments of offshore data and activities are more readily understood by offshore staff and management. This can be explained by considering WFM visualizations to be computer generated abstractions of the real world (shown in Figure 12.4).

The user views the computer visualizations, then interprets and maps them to their user model which is the user's own internal mental model that describes how to interface to a system (Barfield 1993). Inconsistencies between the real-world and the user-model concept of the real-world will lead to problems when interacting with the system. Such problems can be caused by delays that can occur in the construction of the computer's abstraction of the real-world (Figure 12.4-A). For example, a visual update of a computer abstraction may be subject to delays due to hardware update rates etc. Nowadays, this is not really a problem as computer abstractions of the real-world tend to be real-time. A second type of delay can be cognitive delays that occur due to delays in a user's interpretation of an abstracted model (Figure 12.4-B). A number of original abstracted models used in the offshore industry (such

12.4 Future Work

as the original diamond mining visualizations) contained numerous displays consisting of complex visualizations that often took many months to fully comprehend and learn to use (Chapter 10). WFM adopted a natural viewing environment for the abstraction of the real-world which consequently resulted in the user not having to be taught how to interpret the images as they already had a user model interpretation of the abstracted models. This was especially noticeable when novice offshore operators started work and would select WFM as their primary information source from numerous other displays.

12.3.1 Ingrained User Models

Operatives who have used a particular interface for a long time develop an 'ingrained user model' (Barfield 1993). This is a user model which has been built up over time and permits a natural interaction with a system with a minimum of thought².

Just because a more intuitive visualization is available to offshore engineers does not guarantee its use. In fact those offshore engineers with ingrained user models of existing systems (which they may have used for ten years) may be very unwilling to change their working practise in order to interpret new visualizations. Even if engineers wanted to change their working practice and incorporate the WFM visualizations, old habits can sometimes be difficult to break. Ingrained user models were extremely evident when working on the diamond mining vessels.

12.4 Future Work

This section briefly suggests five areas of future offshore marine research that have been realised as a result of work carried out in this thesis. Specifically: stereo marine databases, PDA marine visualizations, sonar registration of 3D objects, predictive scouring and underwater archaeological site visualization.

12.4.1 Implementing a Stereo Marine Database

Chapter 11 described the stereo visualization of computer generated marine environments. Previously in Chapter 8, a method for integrating multiple data sets other than sonar was

²Examples of an ingrained user model would include driving a car, walking or even interfacing to software that one has been using for a long time.

12.4 Future Work

investigated. For example, the user could click on a hotlink icon on a section of pipeline in order to initialise associated ROV video footage. It would be feasible to link stereographic data sets, such as ROV video footage (Woods et al. 1994) with the stereographic computer generated database providing an overall true 3D marine system. The benefits of a completely stereo marine visualization system would need to be investigated. It is predicted that such a stereo system would be useful for on-shore post survey collaborative visualization and discussion of pipeline exposure points.

12.4.2 PDA Technology Visualization

In the last 12 months personal digital assistant (PDA) technology has become more popular within the scientific research community. Modern PDAs now contain powerful processors with large amounts of memory and high resolution displays. Future work would investigate the possibility of porting some of the offshore visualizations described in this thesis to the PDA architecture. It is proposed that the main benefits here would be interacting with entire WFM databases such as a kilometers of pipeline survey data using a single highly portable 4 inch display. The user of the PDA would be able to visualize areas of interest on the pipeline and consider various 'what if?' scenarios. It is highly probable that new visualization techniques would need to be researched due to the reduced display size.

12.4.3 Sonar Registration of 3D Objects and Future Projects

The initial case studies in this thesis described how 3D computer generated objects such as large concrete harbour blocks were precisely positioned by overlaying the objects onto their associated 3D sonar data (Chapter 7). The original system used a semiautomatic program to position the objects (an exact registration algorithm was not developed due to time constraints on the job). Future work would examine how computer generated objects could be precisely positioned and orientated solely from the original sonar data.

As sonar technology improves, and as the oceans become more and more polluted, 3D computer visualization will become more and more popular for real-time sub-sea activities such as ROV piloting. These improvements in sonar quality will enable new offshore projects to be considered. For example, if an accurate 3D model of an oil-rig leg lattice is built, and the quality of sonar systems improves to a level that an ROV could be tracked within the

12.4 Future Work

leg structure (ie within the oil rig), then an accurate visualization of the ROV in relation to the leg structure could be constructed. If the visualization also contained ROV umbilical tracking, then this would enable the ROV pilot to fly more securely around and through the leg lattice knowing the correct exit procedure (ie without tangling the umbilical). Initially some form of calibration would be required to make sure that the real oil rig structure and 3D computer abstraction were correctly registered.

12.4.4 Predictive Scouring

Some of the case studies described in this thesis (such as the Montgomery ship wreck survey in Chapter 6) require annual surveys for comparative and safety reasons. These studies have generally been of a reflective nature. It is proposed that collaboration with oceanologists, geologists and physicists could enable predictive models to be constructed that provide future scouring patterns and wreck disintegration to be predicted (there are now enough annual data-sets for scientific investigation).

12.4.5 Underwater Archaeological Site Visualization

European seas are a repository of wealth and historical remnants as a result of maritime traffic throughout the centuries. Unfortunately, underwater sites of archaeological and historical interest are only accessible to the offshore archeologist and not to members of the general public. The procedures involved in recovering artefacts from the sea bottom and making them available in museums is a difficult and potentially dangerous operation and is likely to destroy the unique nature of the site and the artifacts within.

The goals of underwater archeological site visualization is to allow the public at large to access underwater archaeological sites in the European seas through virtual experiences and multimedia representations. This aim requires multi-disciplinary collaboration from experts in the management of cultural resources, underwater archaeology, enhanced remote learning systems, virtual/augmented reality systems, 3-D scenario reconstruction, image coding and image data-base management and underwater survey and inspection systems.

The author has recently been selected to lead a group of European scientists on the computer visualization of underwater archeological sites. This work will extend the author's work achieved within this thesis and will incorporate novel areas of marine realism (not

12.5 Concluding Remarks

required from an industrial offshore perspective) such as a simulated underwater submarine journey to an underwater archeological site. Challenges ahead may include realistic shoaling (flocking) algorithms for fish, ROV halogen light travelling through the water column and accurate mapping of sonar and photogrammetry data relating to ancient submerged artifacts. Recent advances in pixel shading technology will be used for this research (Fernando & Kilgard 2003).

This thesis has developed the hypothesis that presenting offshore engineers and office based management with more intuitive and natural computer generated viewing environments enables complex offshore tasks, activities and procedures to be more readily monitored and understood. The marine visualizations presented in this thesis take advantage of recent advancements in computer graphics technology and our extraordinary ability to interpret 3D spatial data (Malone 1983), (Spence 2001).

Careful quantitative analysis of a simulated complex offshore scenario in a university laboratory using experienced offshore personnel was never a feasible option within this research. Consequently the author has immersed himself within the offshore industry and worked closely with offshore personnel in order to gain firsthand an improved understanding of the industry. This close interaction coupled with the practical difficulties associated with the harsh offshore working environment led to a more qualitative research methodology that was better suited to the synergetic interaction between offshore and visualization engineer.

The acceptance, success and originality of the work described in this thesis has been proven by its success in industry³ and its success in academic circles with five IEEE publications including two invited papers for IEEE's Computer Graphics and Applications. The real-time marine visualization research outlined in this thesis was awarded Best Case Study Paper at the IEEE Visualization Conference in Salt Lake City, Utah (Chapman et al. 2000).

12.5 Concluding Remarks

Since starting this research in October 1997, an increasing number of marine companies have realised the potential of 3D computer visualization for facilitating offshore operations. This is noticeable from the increased number of 3D marine visualization publications in

³WFM is currently in use with numerous offshore companies such as Debeers, Namco and CSO.

12.5 Concluding Remarks

journals such as *Sea Technology* and *Ocean Systems*. A further increase in publications is expected from industry and academia over the next few years as more and more companies realise the potential of 3D graphics systems for modelling and interpreting underwater data.

It is important to note that 3D is commonly perceived as being 'superior' to 2D. This is incorrect. Information can often be visualized in a more intuitive format in 2D. Novel, effective and popular visualization techniques that are presented at IEEE's Visualization and InfoVis conferences often use 2D visualization techniques. Rendering datasets using three dimensions does not necessarily make a visualization clearer, in fact in many cases it can make a visualization more confusing (added complexity of occlusion etc). Visualizing marine datasets in 3D will only facilitate operations and comprehension of the data if the user retains the ability to interact and manipulate their viewpoint and data. Like in so many instances, 3D visualizations are most successful when we can interact, grab, twist and fly around the datasets. The 3D marine visualization examples described in this thesis have been successful because of their close (and cramped!) development within the offshore environment.

This research has demonstrated that 3D computer graphics and visualization techniques can be used effectively within the offshore environment, both as a planning tool and for real-time situation awareness. Through effective visualization, marine and offshore activities can be made more efficient in their operations: productivity can be increased, training times can be reduced and the comprehension of complex offshore scenarios can be simplified through the use of more intuitive displays.

This thesis began with a quote from Mr Bert Jeeninga who in 1998, boldly stated the potential for 3D computer visualization of the underwater environment (Jeeninga 1998). The Whole Field Modelling system described in this thesis has validated his predictions by making significant improvements to spatial and temporal understanding of offshore data and activities.

Appendix A

Data Structures

A.1 DTM

The DTM digital terrain maps used by WFM are binary files that contain a square area of seabed. Each DTM contains a 36 byte header which contains the Easting and Northing of the top left and bottom right coordinates of the square area of seabed.

Every DTM will contain an 18 point border that is used for filtering and image processing. The individual depth files are stored as short integers and are stored in centimeter depth. The resolution of a DTM is dependent on the number of data points in the map and the geographical distance stored within the map.

This information is all stored with the *dtm.dat* file located within the DDT tree (described below). Note that the number of data points represented within the DTM can be calculated (Equation A.1.1) as the header will always contain 36 bytes and the map will always be square.

$$\text{Datapoints} = \left(\sqrt{\frac{(\text{filesizeinbytes} - 36)}{2}} \right)^2 - 36 \quad (\text{A.1.1})$$

While surveying the seabed with sonar, sonar returns may not be gathered and processed for every section of seabed. Consequently, small areas of a DTM will contain holes. Small holes may be filled using standard image processing techniques (such as a Gaussian filter). Large holes however must remain in the DTM. Holes within the DTM are represented by the smallest number possible using signed integers (-32768).

The example DTM shown in Figure A.1 contains 536^2 datapoints. The distance covered may be 200m^2 which would give a resolution of $\frac{200}{500} = 40\text{cm}$.

A.1 DTM

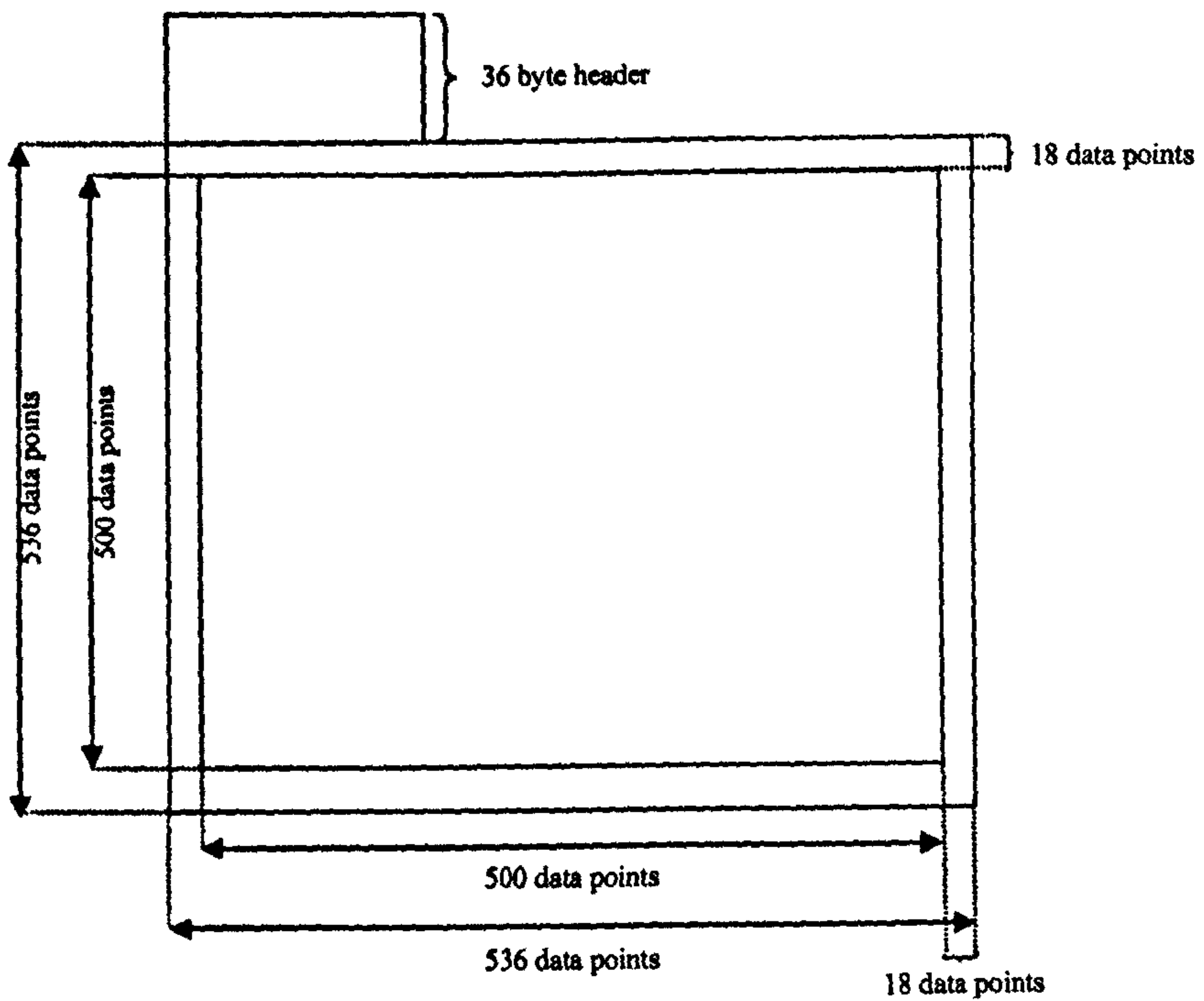

Figure A.1: DTM Structure

A.2 DDT

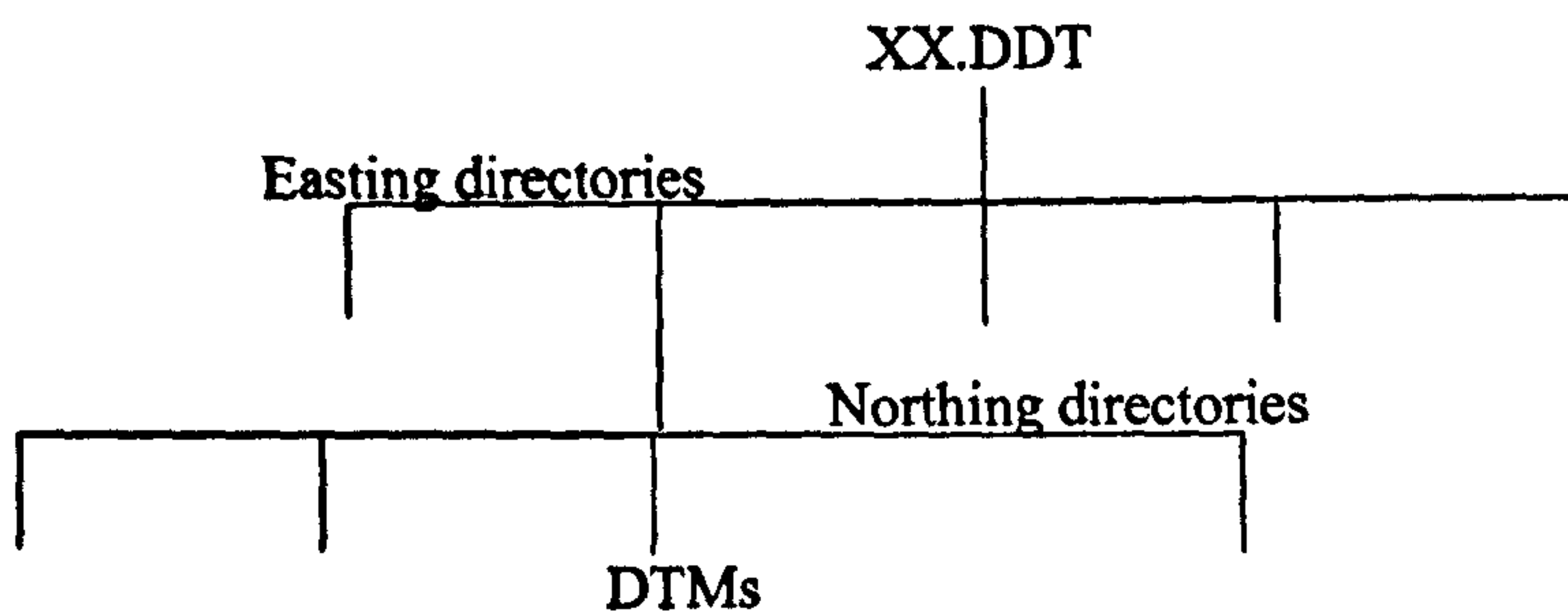

Figure A.2: DDT directory structure

A.2 DDT

A DDT is a file structure used to store a collection of DTMs. A DDT hierarchy will consist of the *xxx.DDT* root containing a number of subdirectories labelled numerically in Eastings. The Easting directories contains a number of numerically labelled Northing subdirectories which in turn contain the relevant digital terrain map (for example *mindepth.dtm*) and a contents file (*contents.tab*) that contains information on how the DTM was constructed.

A.3 PIF

The pipe information file structure stores a number of 'hits'. Each 'hit' represents a confirmed top of pipe position acquired from bathymetric and sub bottom profiler sonar techniques (Section 2.6.4). The file structure consists of:

PIF, Number of Records, Pipe diameter, Description, {KP, Easting (m), Northing (m), Offset from route (m), Depth of seabed (m), Depth of burial (m), Origin of data}

The origin of data can be:

- As given (provided by the client)
- As found with SVS or SBP
- As gathered from a land survey

A.3.1 Calculating a Transformation Matrix for a Pipe Section

The equations and transformation matrix shown in Equations A.3.1 and A.3.4 describe the necessary mathematics to scale, rotate and translate a section of pipeline¹ to fit between two captured pipeline positions (PIF_n and PIF_{n+1} taken from the pipe information file). F represents the final transformation matrix that will scale, rotate and translate a single section of pipeline between PIF_n and PIF_{n+1} . These pipeline sections can then be concatenated to form a continuous 3D pipeline model.

$$\begin{aligned}
 \bar{P} &= PIF_{n+1} - PIF_n \\
 \bar{T} &= \overline{PIF_n} + \frac{\bar{P}}{2} \\
 \bar{S} &= (\text{pipeDiameter}, \text{pipeDiameter}, |\bar{P}|) \\
 \psi &= \pi + \arctan 2 \frac{PIF.x_{n+1} - PIF.x_n}{PIF.z_{n+1} - PIF.z_n} \\
 \theta &= \arcsin \frac{PIF.y_{n+1} - PIF.y_n}{|\bar{P}|}
 \end{aligned} \tag{A.3.1}$$

$$T = \begin{pmatrix} 1 & 0 & 0 & T_x \\ 0 & 1 & 0 & T_y \\ 0 & 0 & 1 & T_z \\ 0 & 0 & 0 & 1 \end{pmatrix}, R_y(\psi) = \begin{pmatrix} \cos(\psi) & 0 & \sin(\psi) & 0 \\ 0 & 1 & 0 & 0 \\ -\sin(\psi) & 0 & \cos(\psi) & 0 \\ 0 & 0 & 0 & 1 \end{pmatrix}$$

$$R_x(\theta) = \begin{pmatrix} 1 & 0 & 0 & 0 \\ 0 & \cos(\theta) & -\sin(\theta) & 0 \\ 0 & \sin(\theta) & \cos(\theta) & 0 \\ 0 & 0 & 0 & 1 \end{pmatrix}, S = \begin{pmatrix} S_x & 0 & 0 & 0 \\ 0 & S_y & 0 & 0 \\ 0 & 0 & S_z & 0 \\ 0 & 0 & 0 & 1 \end{pmatrix}$$

$$F = T.R_y.R_x.S \tag{A.3.4}$$

¹Assumes pipeline is a 1m³ cylinder centred along the Z axis.

A.3.2 Pipeline Cross-sections

The problem of occluded buried pipes can be overcome through the use of cross-section displays. Initially two positions must be calculated that are orthogonal to the direction of the pipeline at a given point. A linear interpolation can then be performed between these two points and cross-referenced to the associated digital terrain map.

The transformation matrix for calculating the cross section extremities is shown in Equation A.3.6. Bearing (ψ) was previously calculated in Equation A.3.1. The offset λ denotes the distance of the cross-section point from the pipeline.

$$\mu = \begin{cases} \psi + \frac{\pi}{2} & \text{Port cross-section limit;} \\ \psi - \frac{\pi}{2} & \text{Starboard cross-section limit.} \end{cases} \quad \begin{array}{l} \lambda = \text{Starboard Cross-section limit} \\ \end{array} \quad (\text{A.3.5})$$

$$\begin{pmatrix} \cos(\mu) & 0 & \sin(\mu) & \lambda \\ 0 & 1 & 0 & 0 \\ -\sin(\mu) & 0 & \cos(\mu) & 0 \\ 0 & 0 & 0 & 1 \end{pmatrix} \quad (\text{A.3.6})$$

Appendix B

Dynamic Runtime Objects

A publication by Smetak & Caputo (1997) describes how to keep large projects under control using a concept of dynamic runtime objects. This concept forces developers to segregate code in such a way that the tendency toward inappropriate object dependencies is greatly reduced. Appropriate dependencies are handled in a 'uniform, understandable and manageable fashion'. The end result therefore is an application that is well organised and easy to extend by the users at runtime. This Dynamic Runtime Object architecture has enabled the author to implement the modular visualization environment concepts described in Chapter 3.

The 'modules' described within this thesis (used for the construction of marine visualization architectures) are themselves runtime objects and views that live in separate MFC extension DLLs. The objects are hosted by a generic container application called ObjectView.

Three components make this system work: a class broker, a view broker and an object broker. The object broker uses ActiveX structured storage and manoeuvres objects in and out of memory as required reducing the application's overhead. This methodology is extensible to situations that require multiple views on complex objects with complex and intricate interdependencies. This methodology is used to create three different dynamic objects that live in MFC Extension DLLs. Each DLL houses a dynamic object class and associated graphical user interface classes (Figure B.1). The first DLL demonstrates how a view should interact with a dynamic object and how to handle persistent data for dynamic objects. The second DLL demonstrates how to handle object interdependencies and the third DLL demonstrates the concept of interchangeable classes which is useful to provide

hooks for customizing applications at runtime.

One of Smetak and Caputo's design axioms is that good architectures should keep user interface objects and classes separate from functional object classes. For example, `CSimpleView` is the user interface class and `CSimpleObject` is the functional class. `CSimpleView` may hold a reference to `CSimpleObject` but `CSimpleObject` should have no knowledge of `CSimpleView`. `CSimpleView` can access `CSimpleObject` by using the view broker and object broker. The view broker will send a `WMOBJECTINFO` custom message that includes a unique key associated with the dynamic object needed. Given the key, the object broker can get hold of and provide access to the required dynamic object. A pointer to the object is also passed with the message.

The three key components that support the extensibility of dynamic runtime objects are the class broker that registers classes for dynamic objects. The view broker that manages views on different objects and the object broker that dispenses dynamic objects as requested.

A thorough and detailed explanation of the above concepts can be found in (Smetak & Caputo 1997).

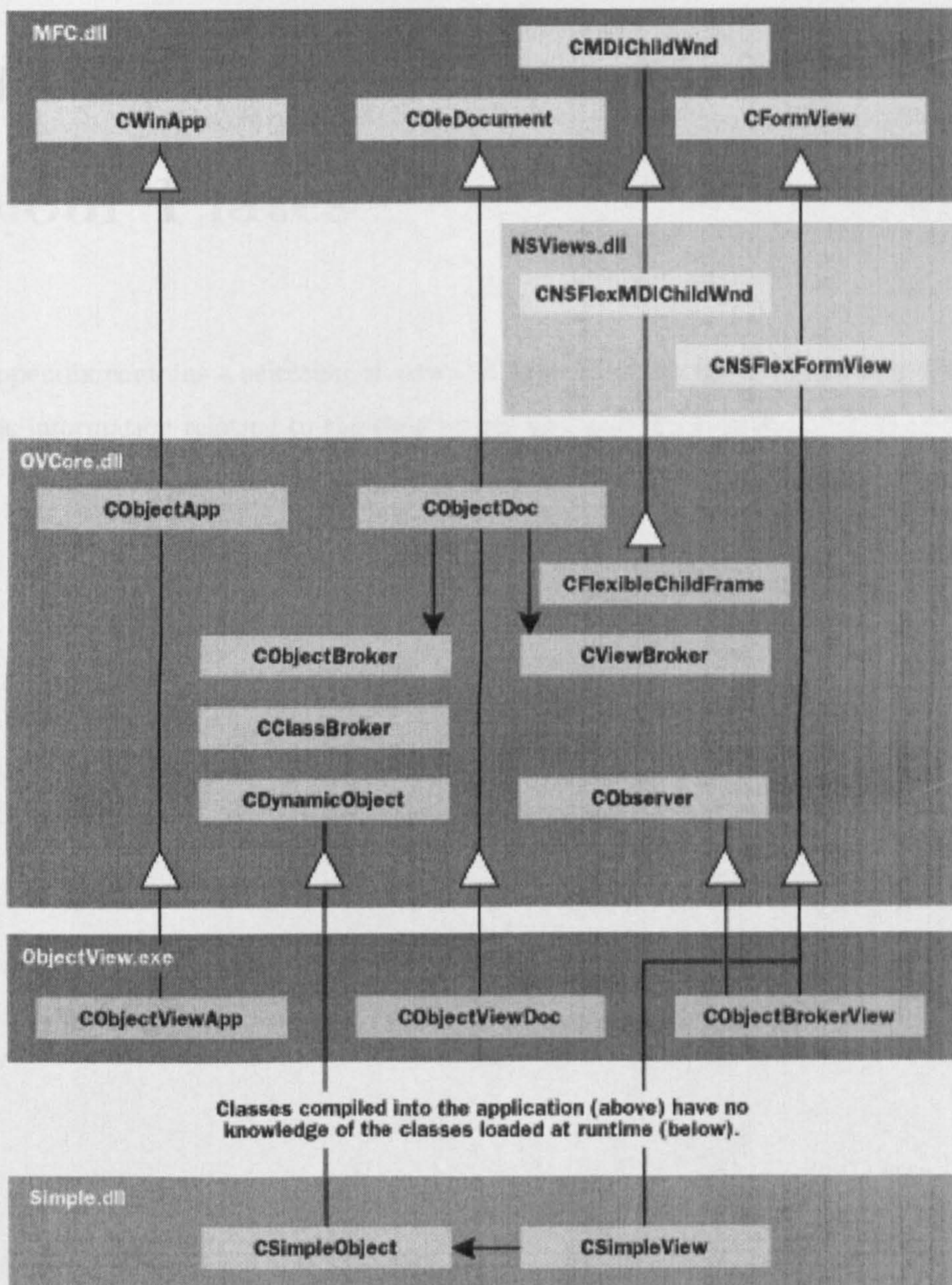

Figure B.1: `CSimpleObject` and `CSimpleView` (Smetak 1997)

Appendix C

Colour Plates

This appendix contains a selection of visualizations from this thesis. Each figure's caption contains information relating to the data source and related chapter.

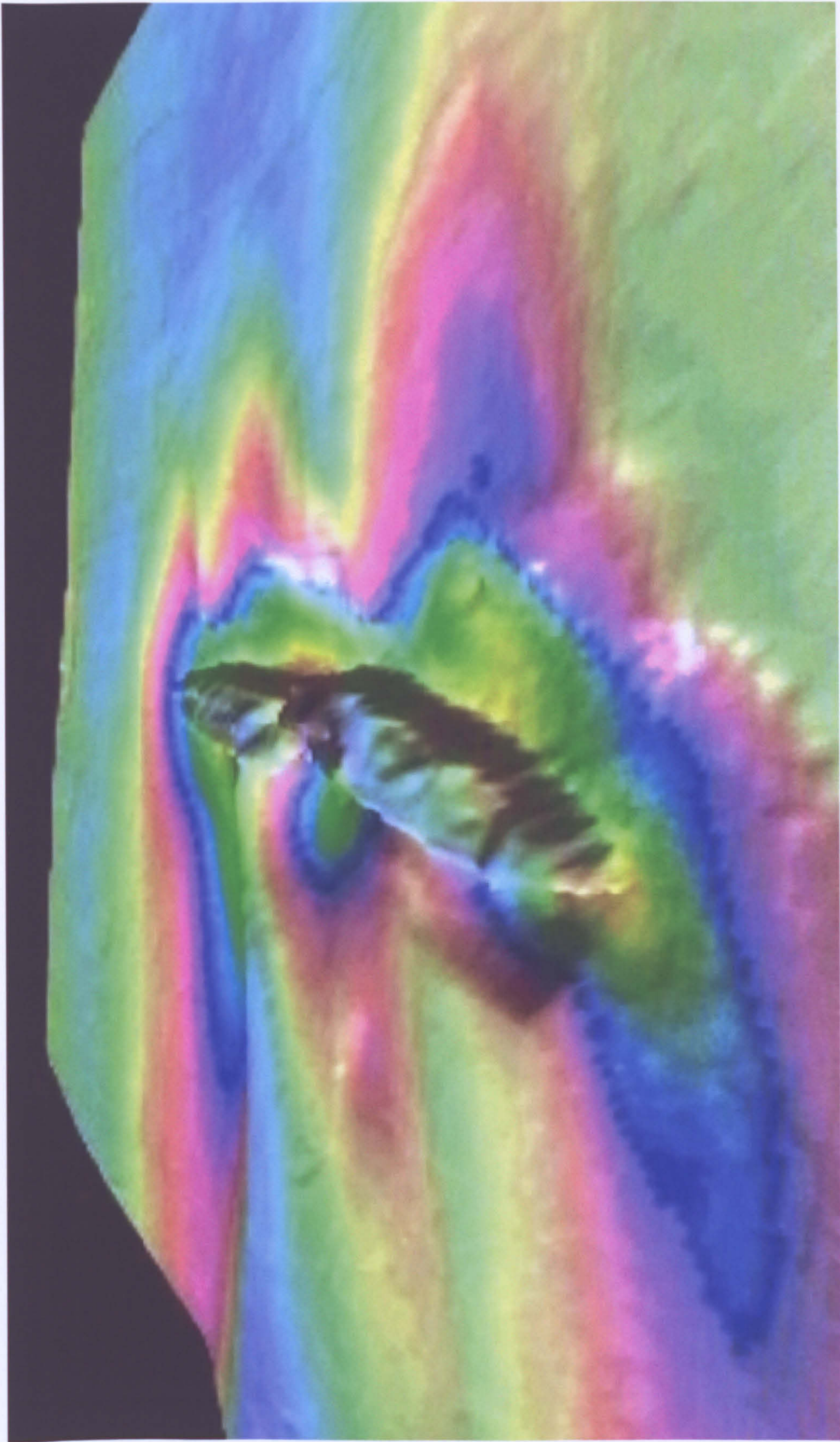

Figure C.1: Chapter 6 : Bathymetric data showing the SS Richard Montgomery



Figure C.2: Chapter 6 : Bathymetric data with accurately positioned shipwreck model



Figure C.3: Chapter 6 : Coloured bathymetry with accurately positioned shipwreck model



Figure C.4: Chapter 6 : Simulating a realistic underwater environment using fog

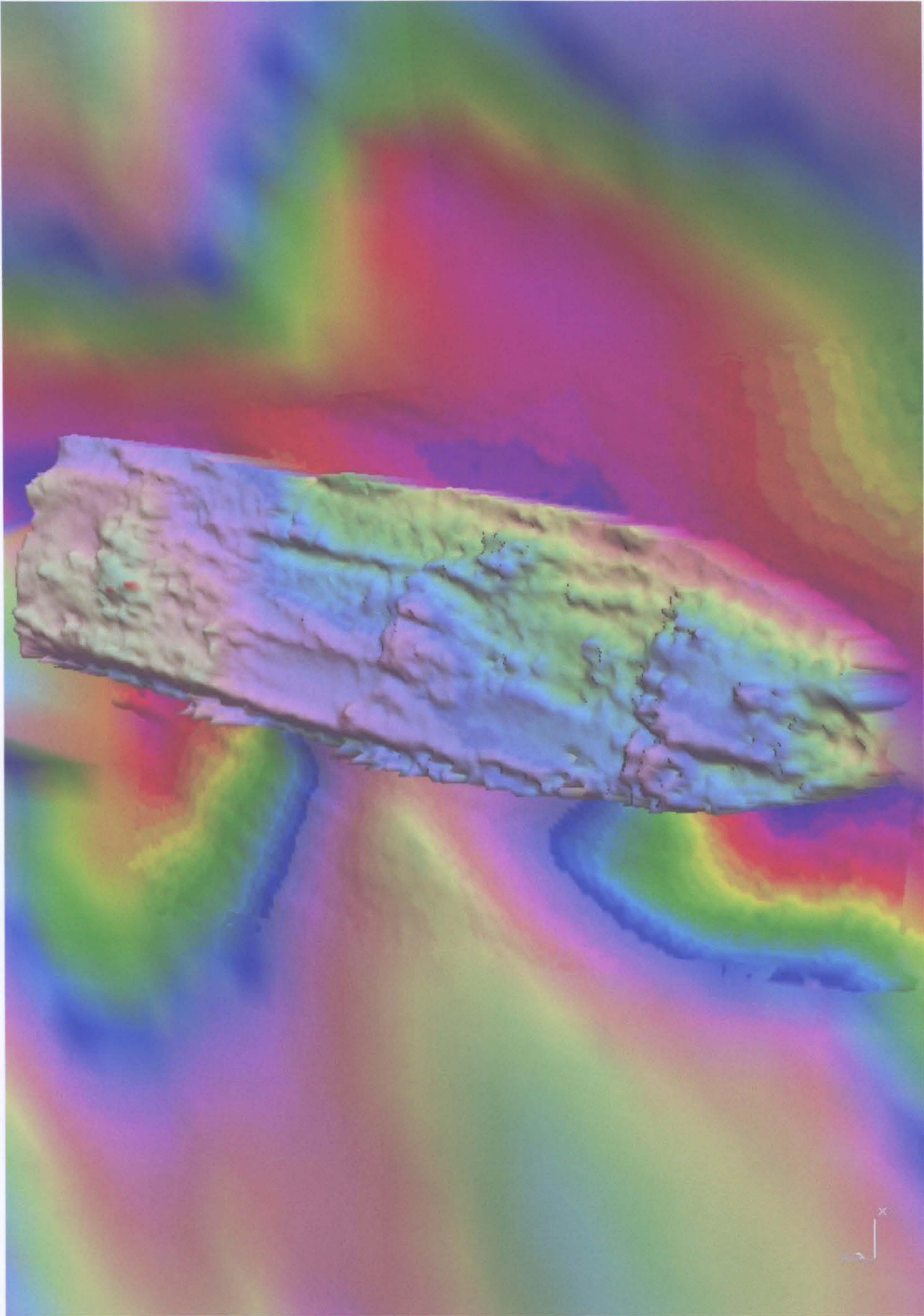

Figure C.5: Chapter 6

High resolution data shipwreck lying on a reduced resolution seabed

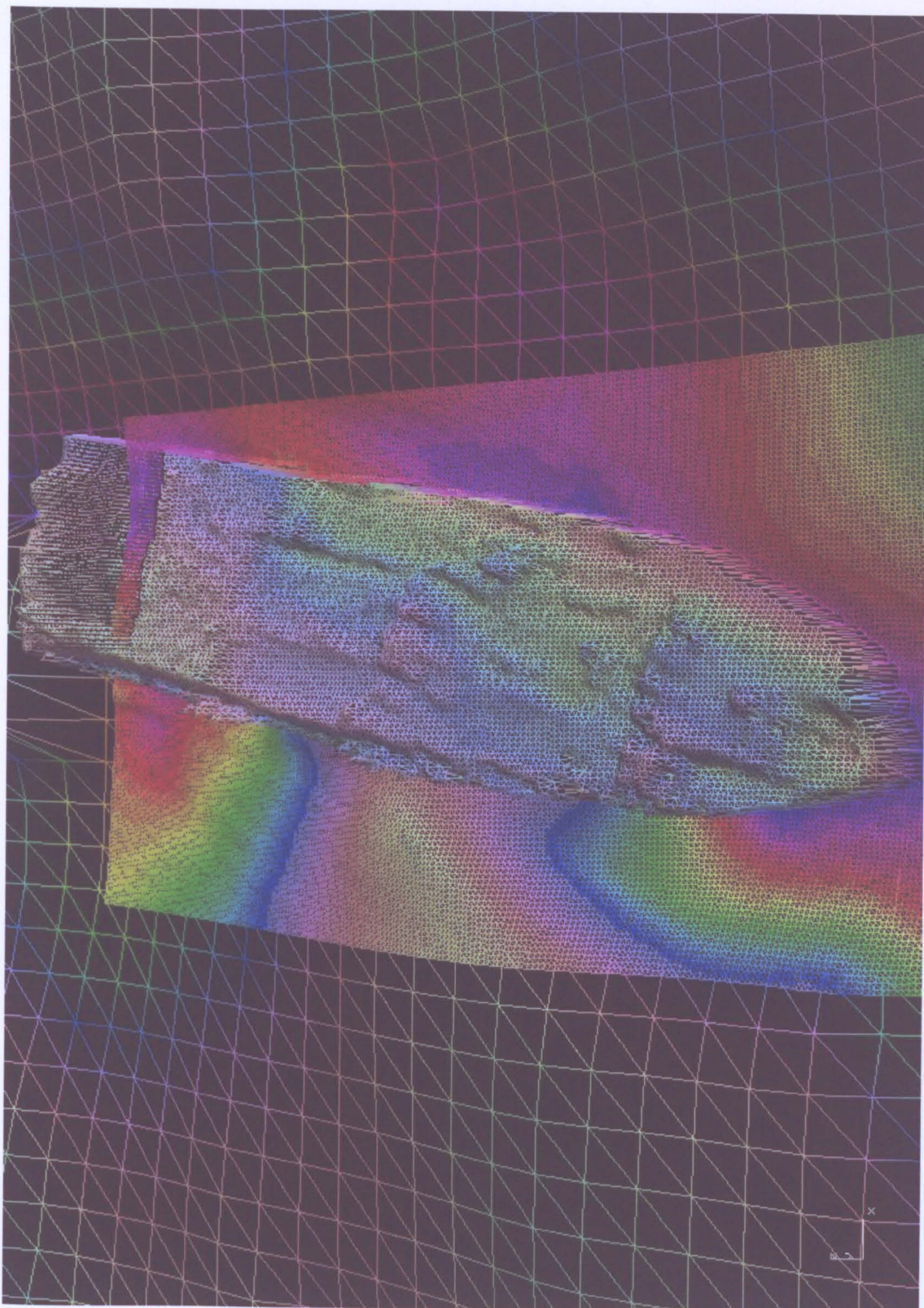

Figure C.6: Chapter 6 : High resolution data shipwreck lying on a reduced resolution seabed (wireframe)

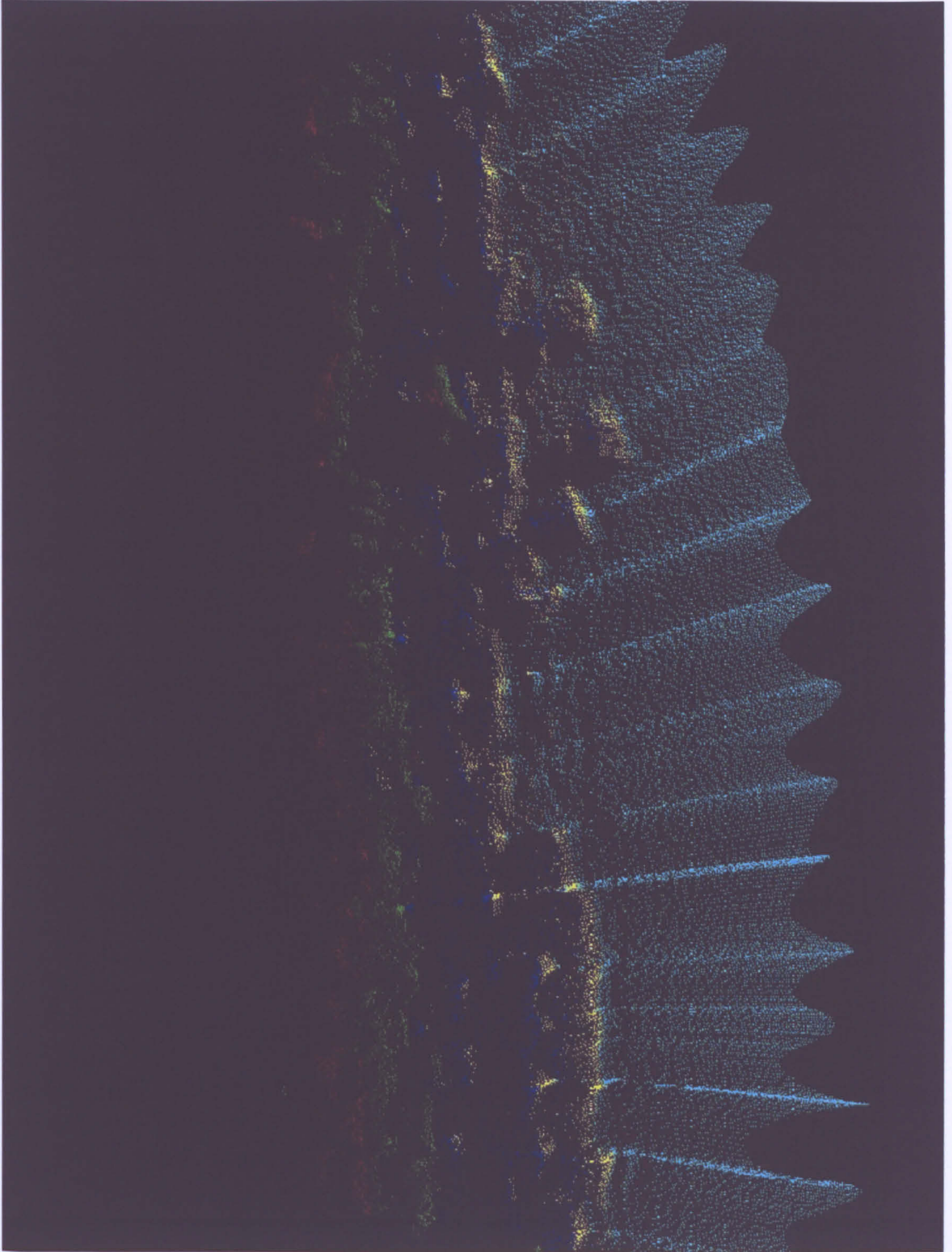

Figure C.7: Chapter 7 : Harbour wall visualization EDT data

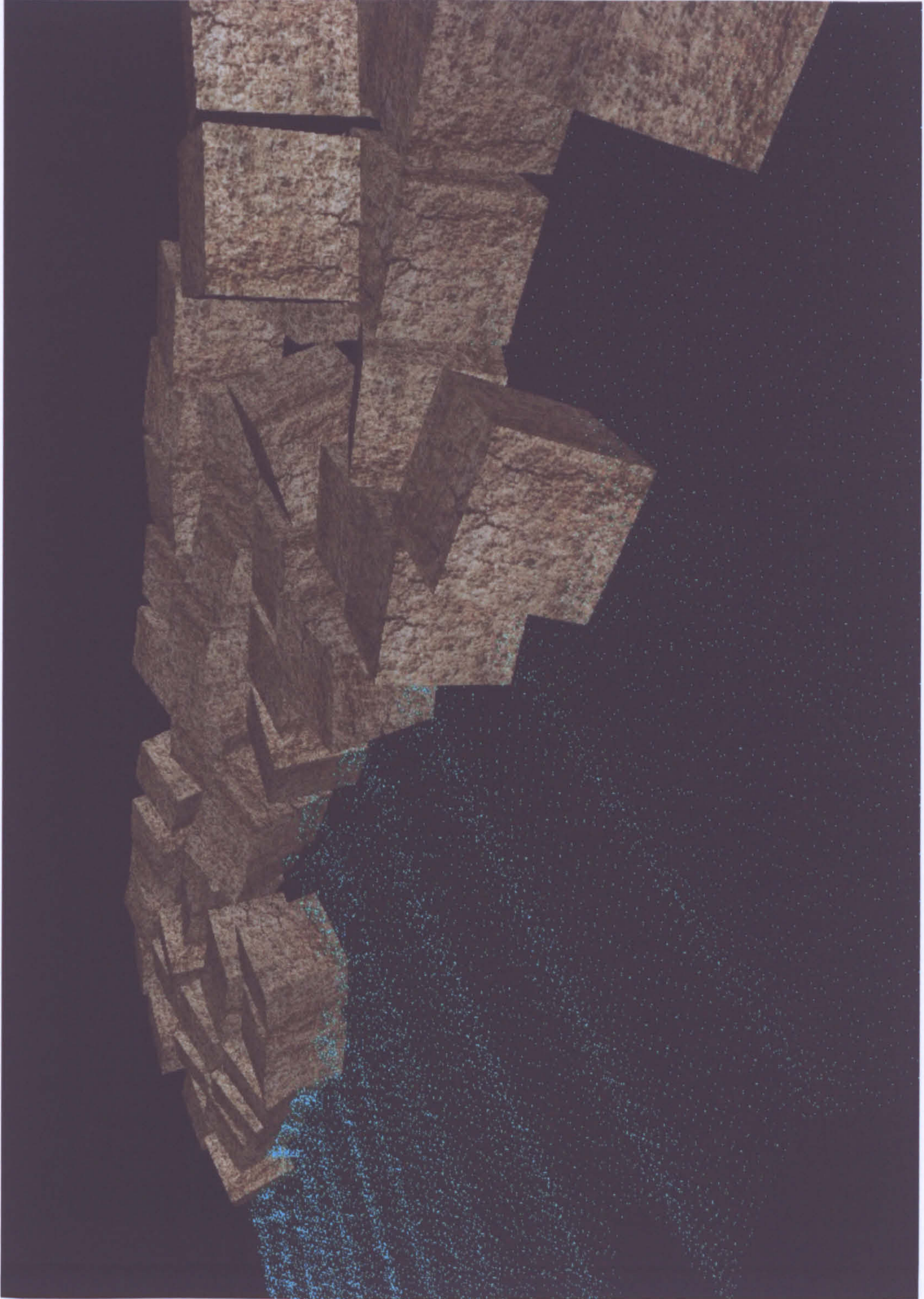

Figure C.8: Chapter 7 : Virtual harbour wall environment

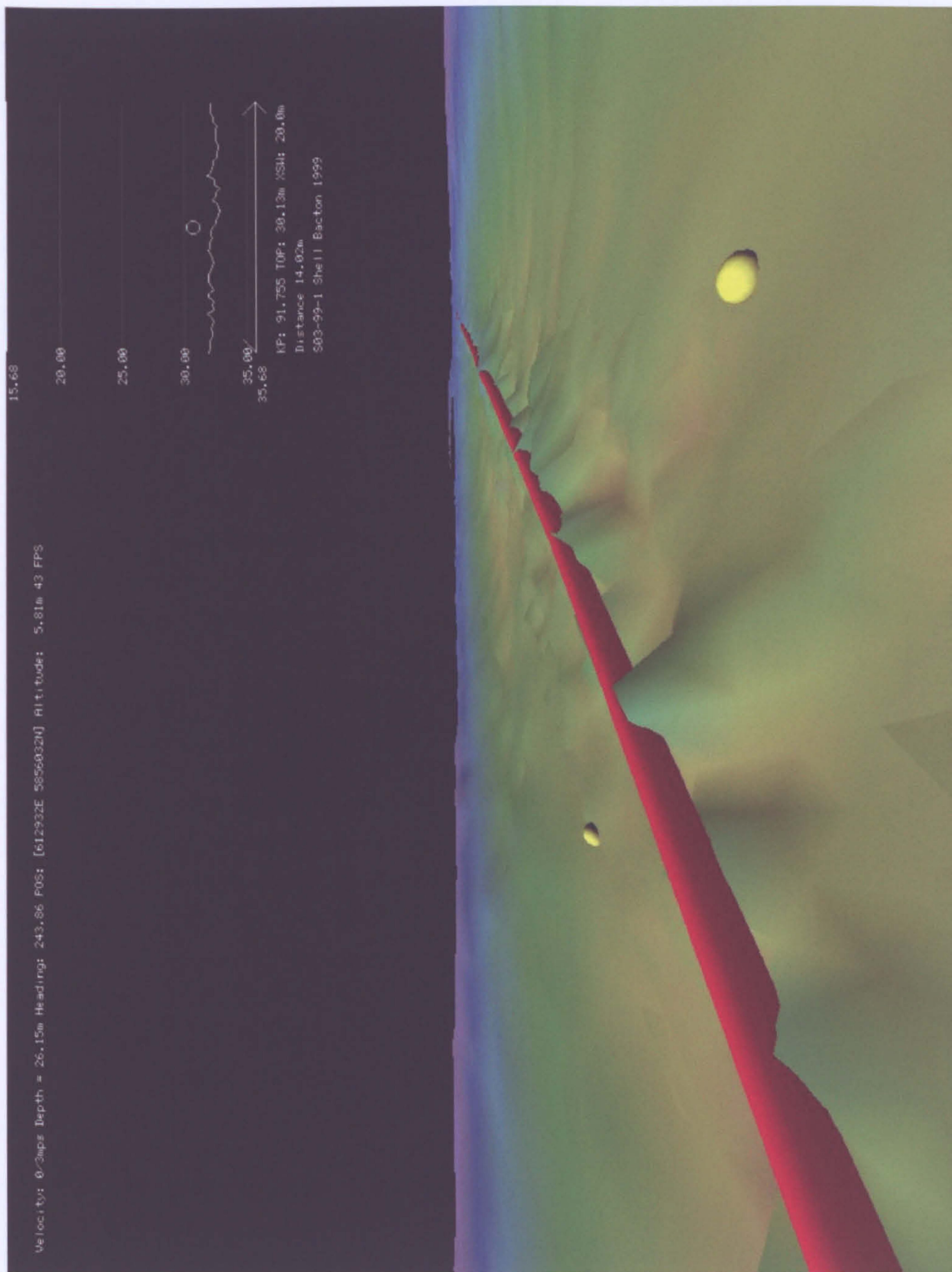

Figure C.9: Chapter 8 : Investigating pipeline exposure points

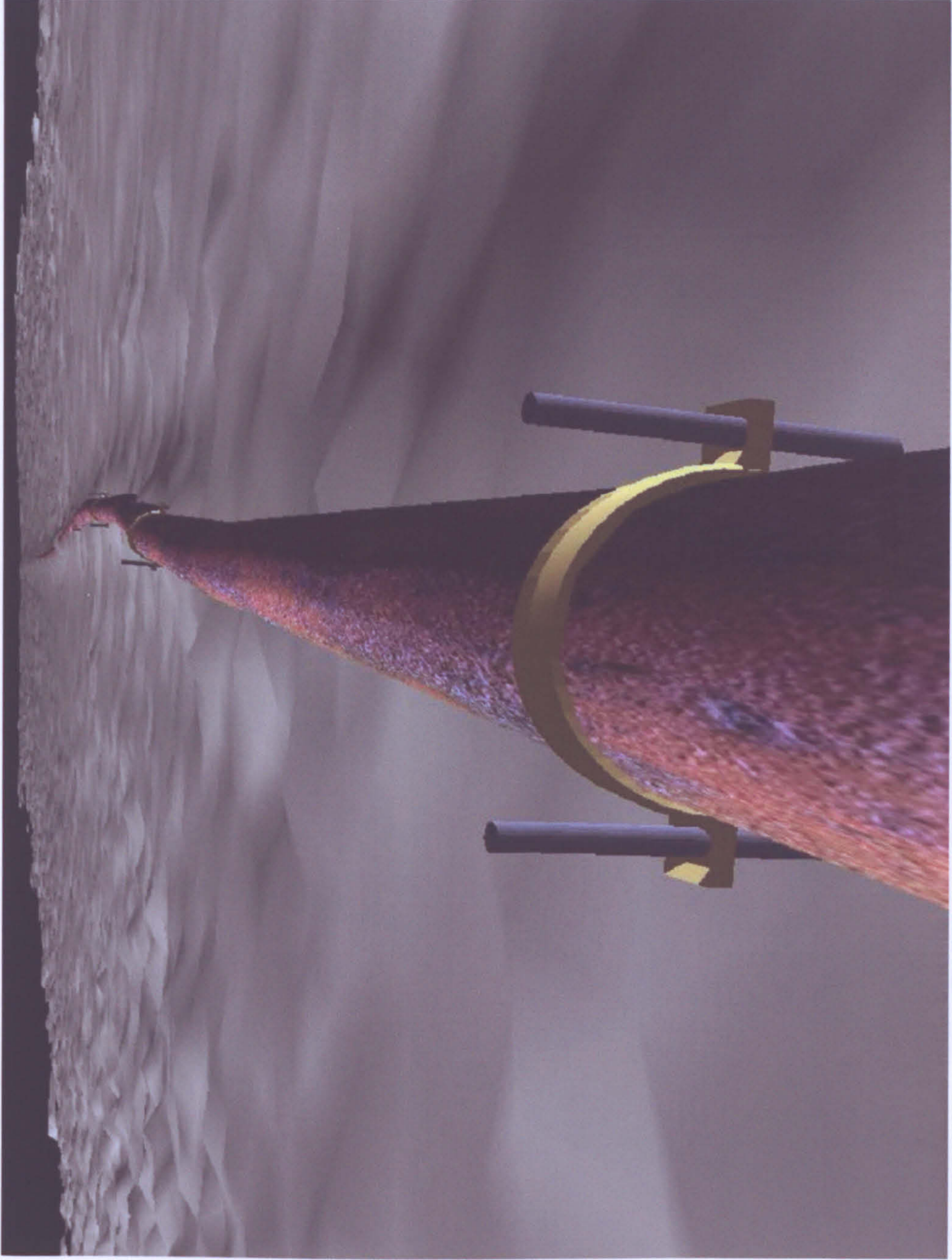

Figure C.10: Chapter 8 : Real pipeline, real seabed, virtual screwed anchor

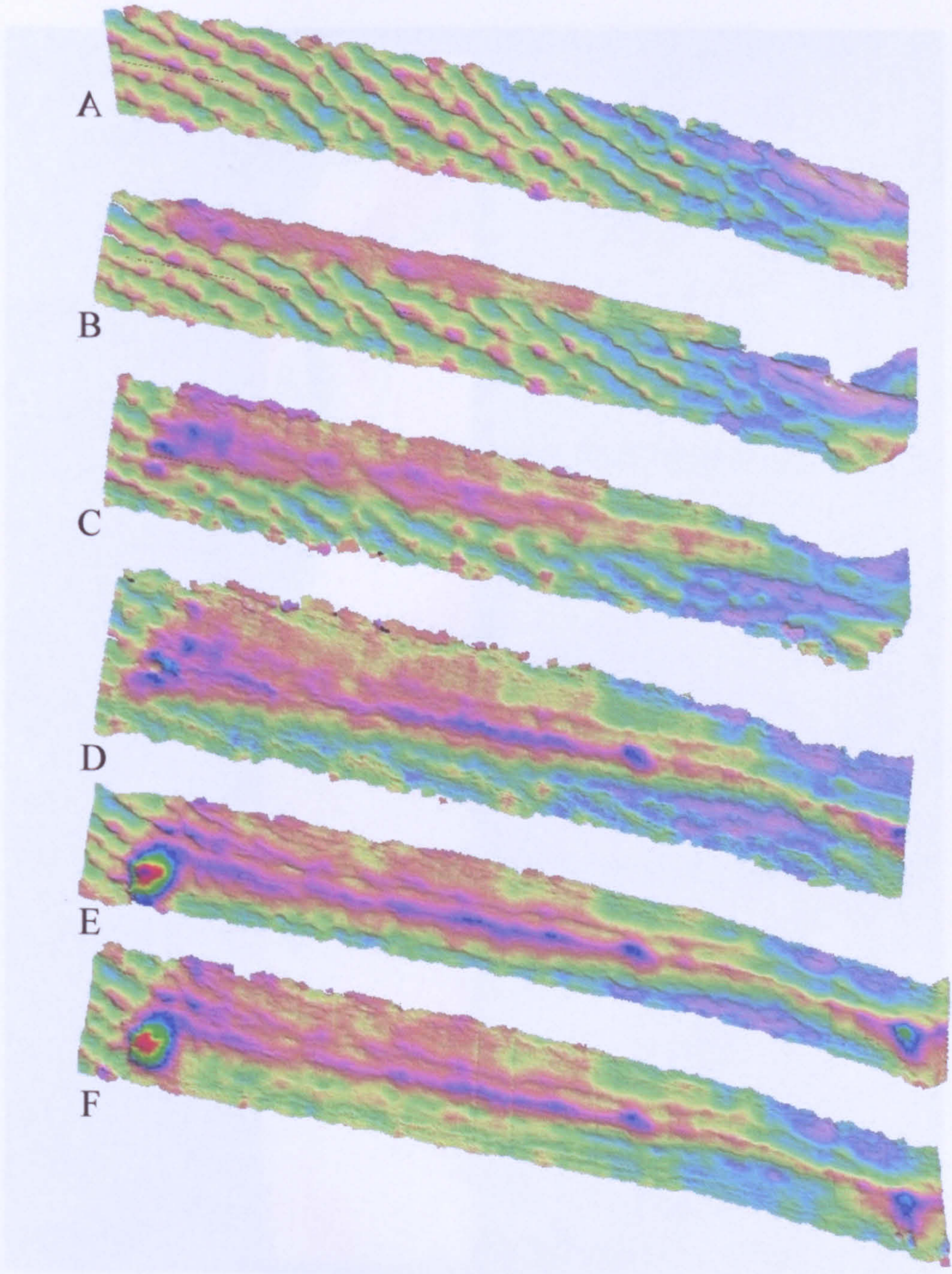
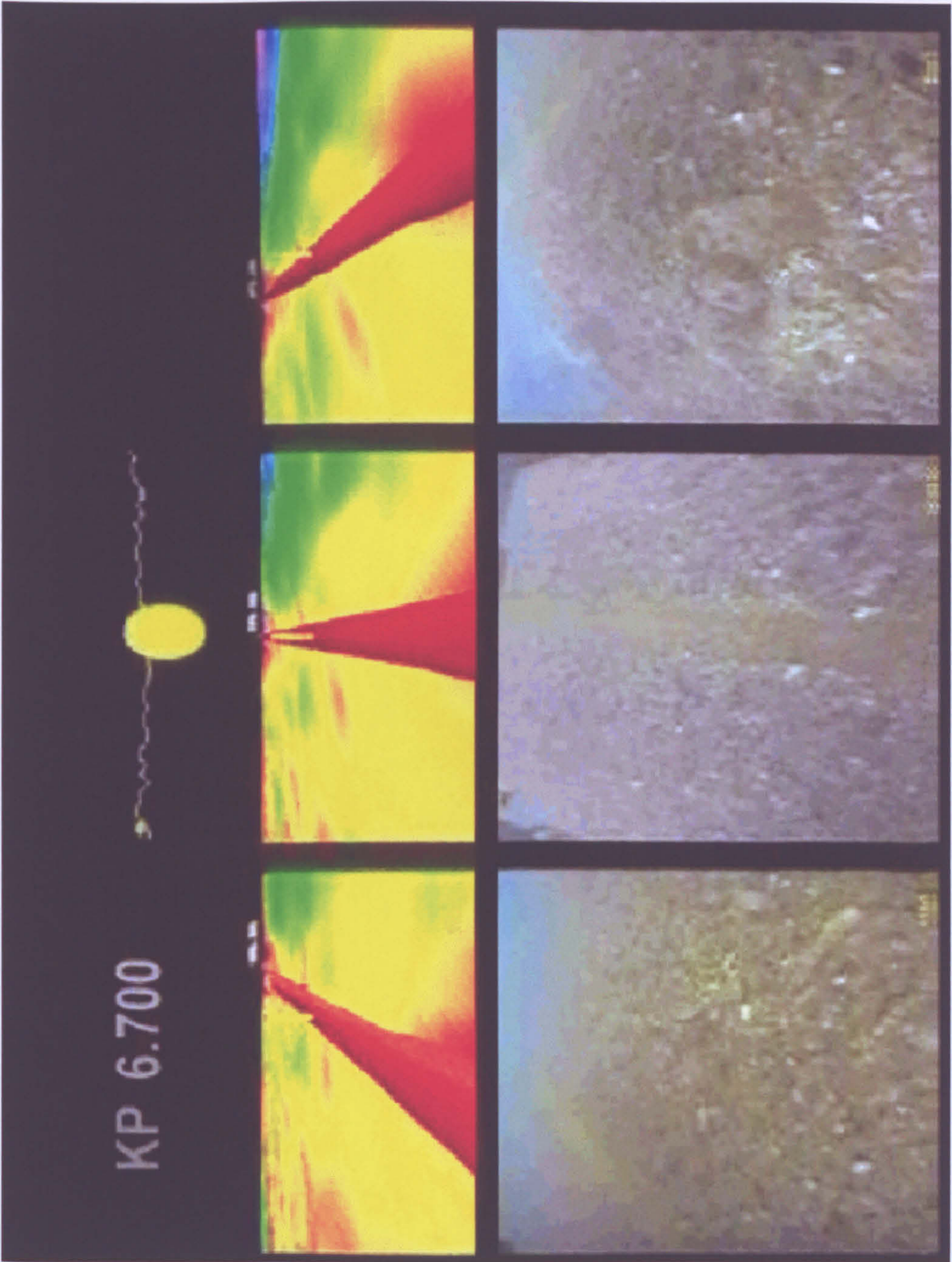

Figure C.11: Chapter 8 : Iterative Dredging Process



KP 6.700

Figure C.12: Chapter 8 : Model validation - Integrating ROV and virtual displays

Figure C.12: Chapter 8 : Model validation - Integrating ROV and virtual displays

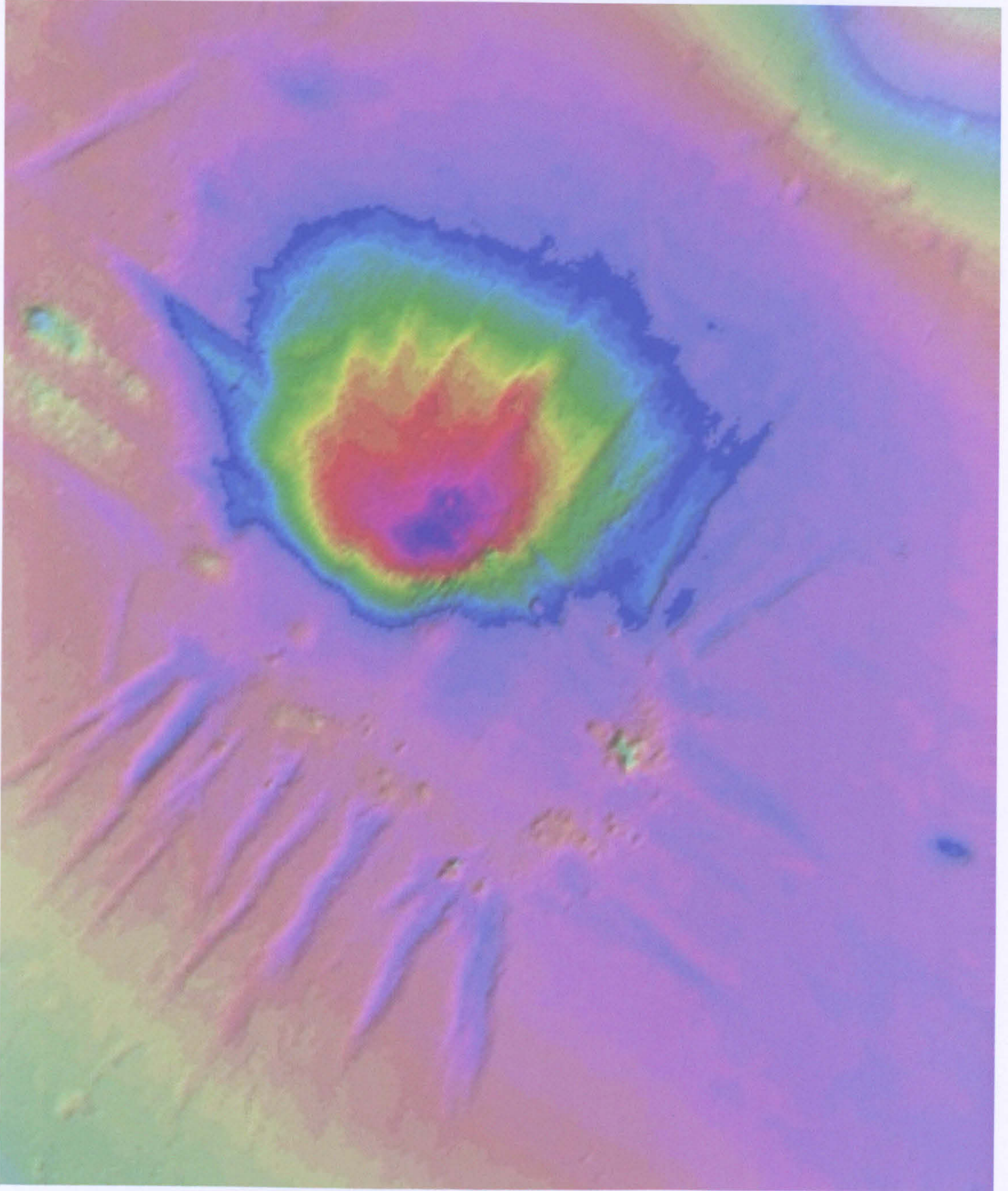

Figure C.13: Chapter 9 : Depth coloured bathymetric plot of Holy Loch



Figure C.14: Chapter 9 : WFM real-time display of clear up operations



Figure C.15: Chapter 9 : Grab breaking water level with debris flag set

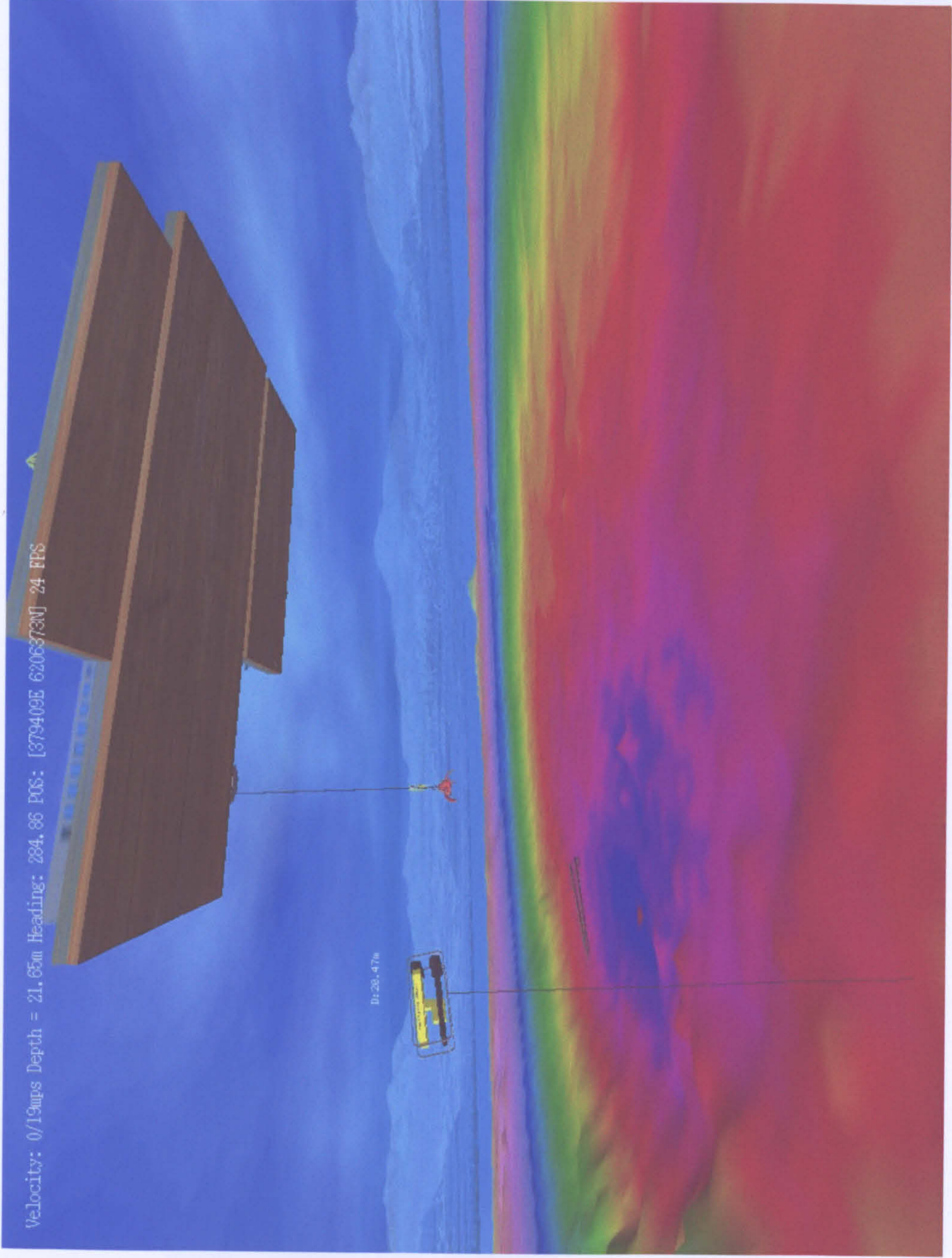

Figure C.16: Chapter 9 : Typical party chief selected view

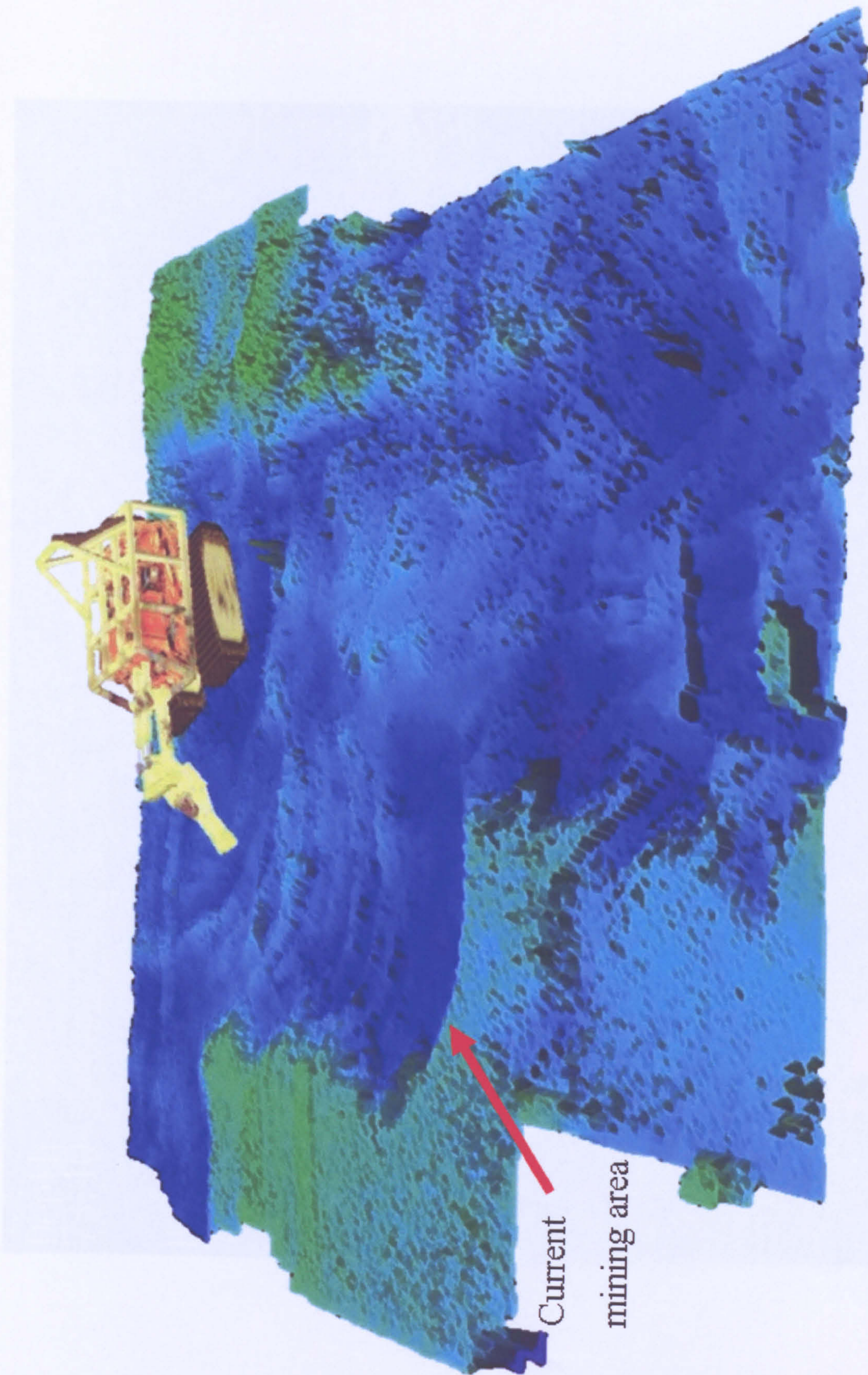

Figure C.17: Chapter 10 : Real-time WFM crawler visualization

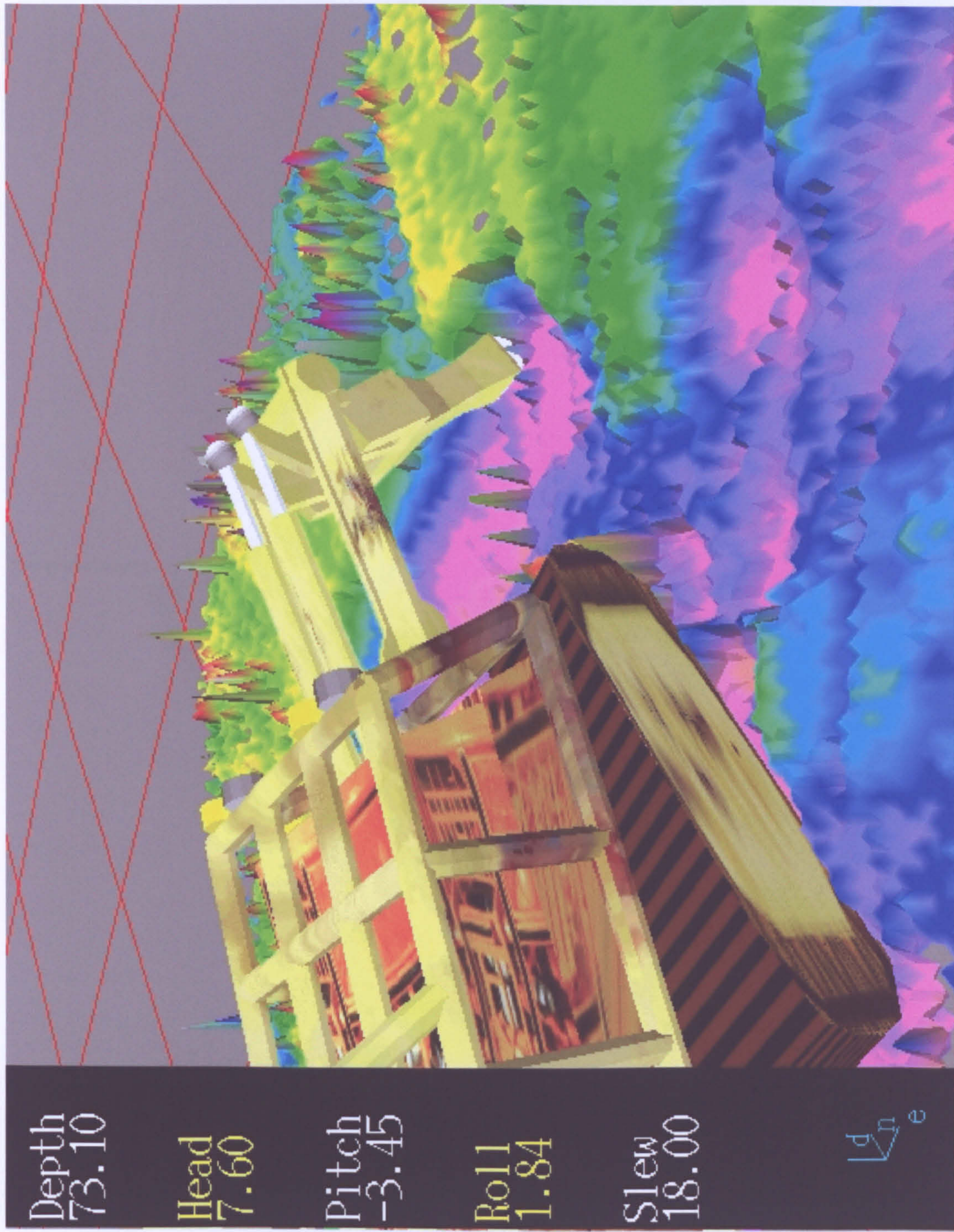

Figure C.18: Chapter 10 : Real-time dredging display including crawler positional data (left)



Figure C.19: Chapter 10 : Tool deployment visualization

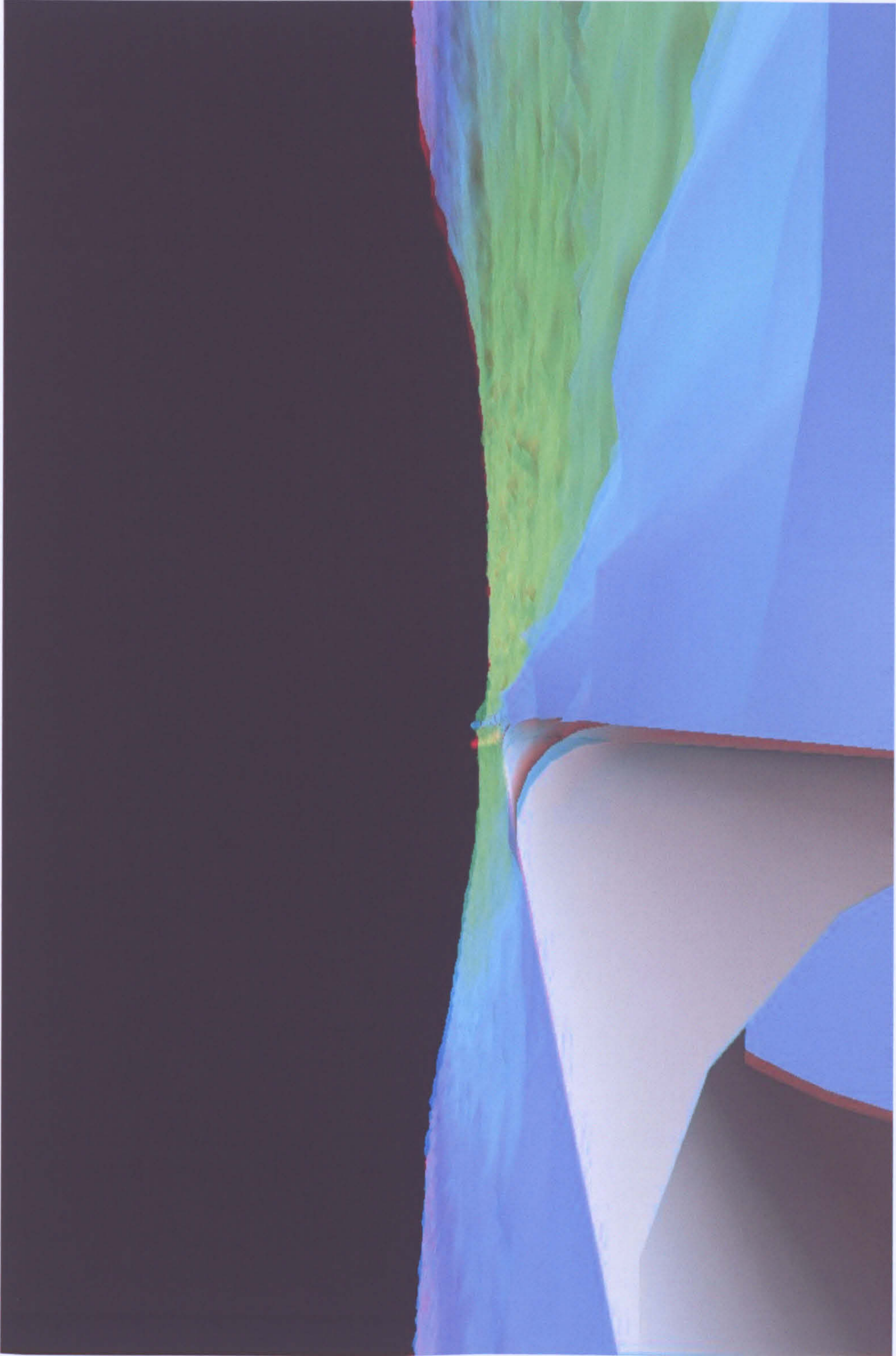

Figure C.20: Stereographic view of an exposed section of pipeline (red-blue glasses required)

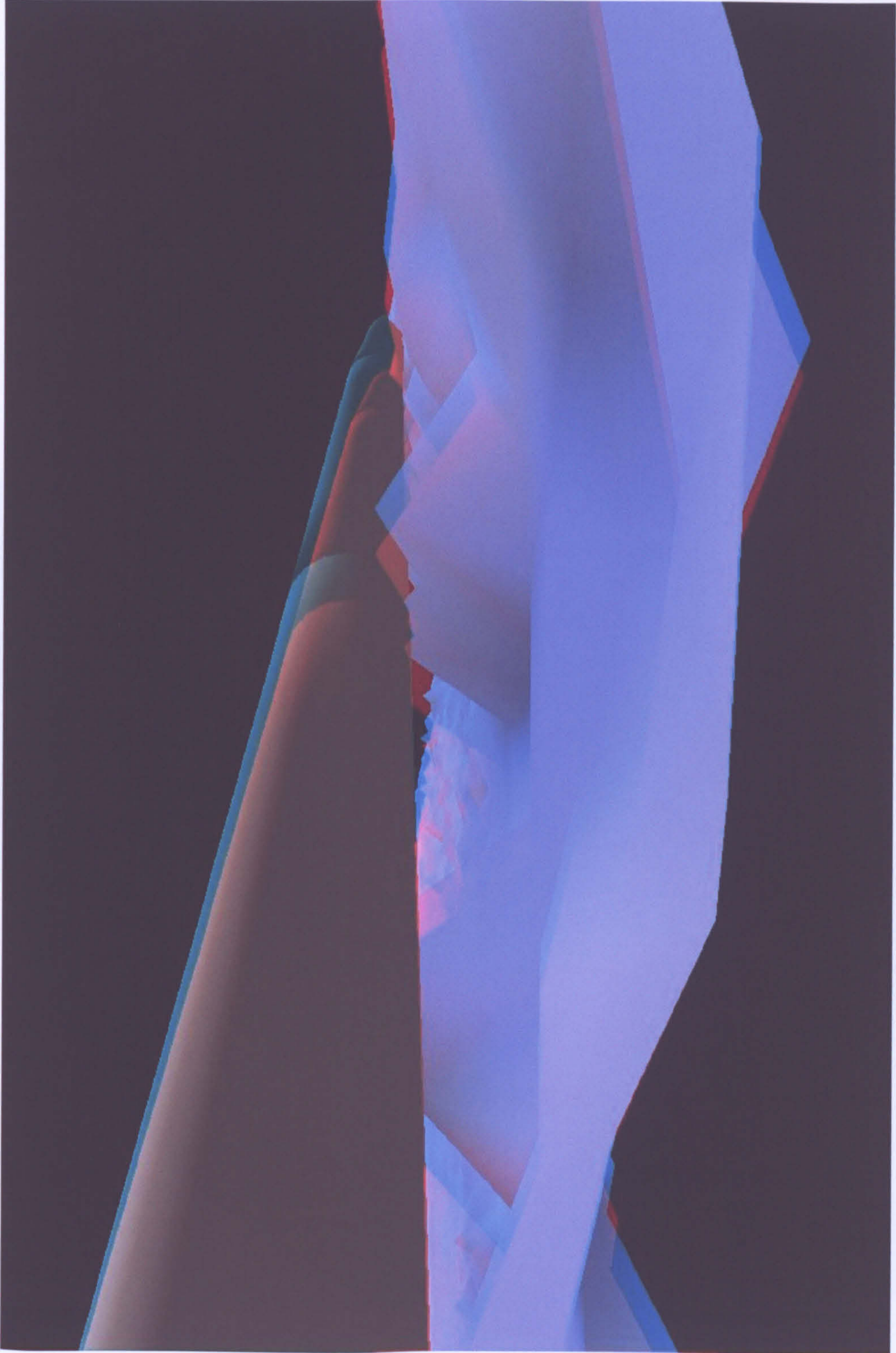

Figure C.21: Stereographic view of a free-spanning section of pipeline (red-blue glasses required)

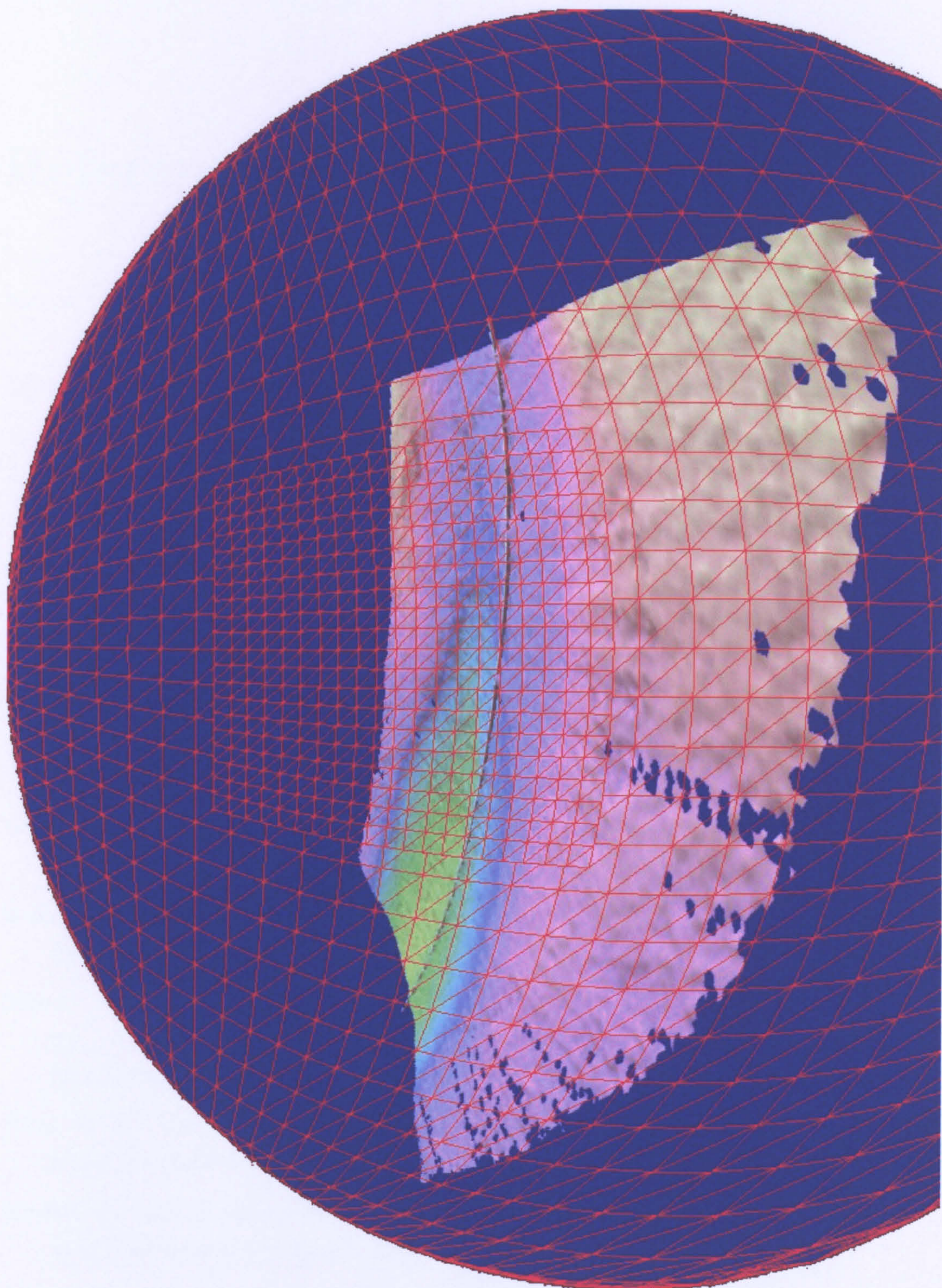

Figure C.22: Hemispheric pipeline projection including wireframe hemisphere mesh

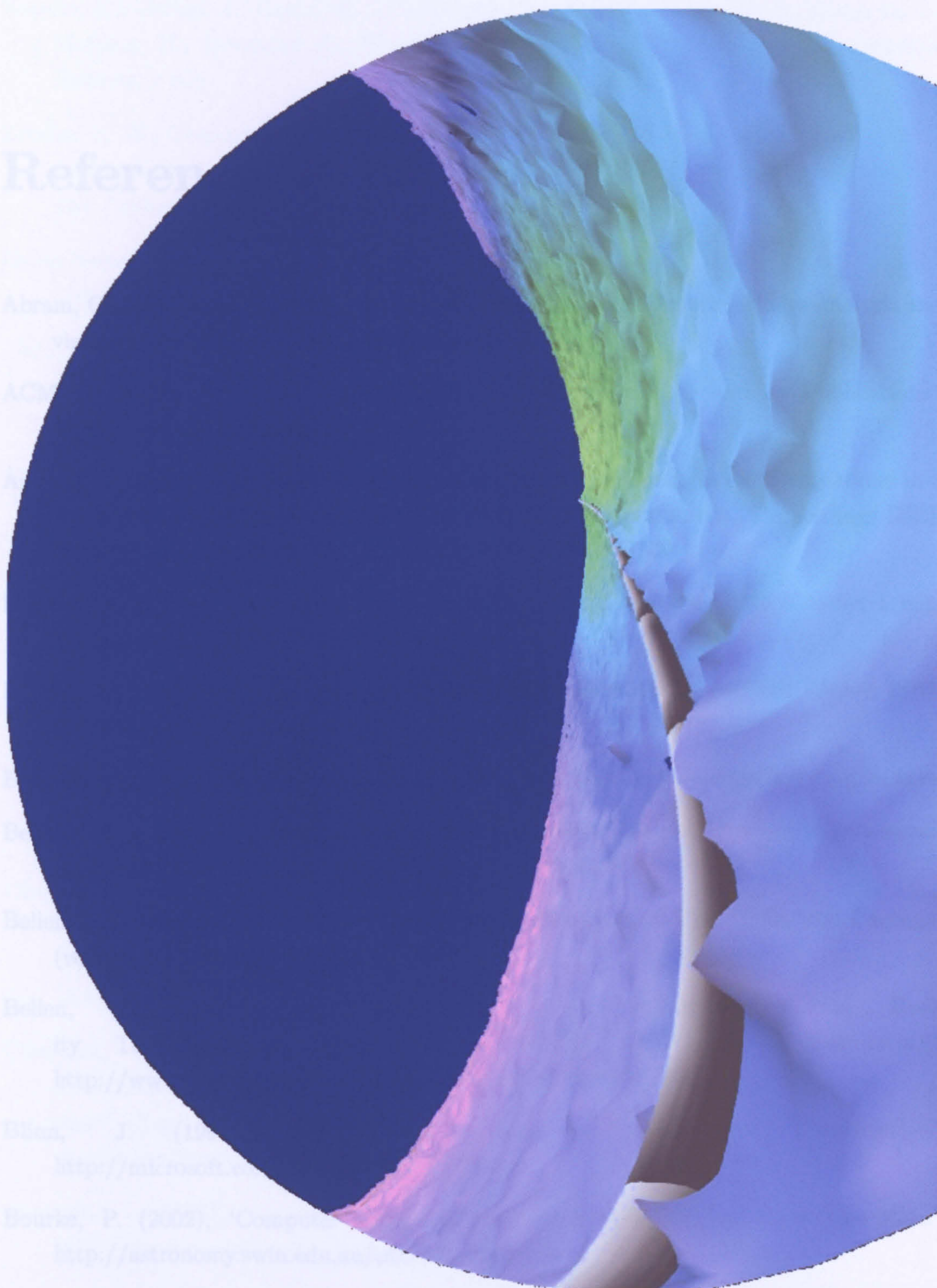

Figure C.23: Hemispheric pipeline projection

References

- Abram, G. & Treinish, L. (1995), 'An extended data-flow architecture for data analysis and visualization', *Computer Graphics* 29(2), 17–21.
- ACM (2002), 'ACM SIGGRAPH Programmes and Publications'.
<http://www.siggraph.org/>.
- Azuma, R., Ill, H. N. & Daily, M. (1999), Visualization of Conflicts and Resolutions in a 'Free Flight' Scenario, in M. G. David Ebert & B. Hamann, eds, 'Proceedings IEEE Visualization '99', IEEE, pp. 433–443. ISBN 0-7803-5897-X.
- Ballard, R. D., Archbold, R. & Crean, P. (1995), *The Discovery of the Titanic*, 1 edn, Warner Books. ISBN 0-4466-7174-6.
- Barfield, L. (1993), *The User Interface Concepts and Design*, 2 edn, Addison Wesley. ISBN 020154415.
- Behringer, R. (2002), 'Z-anaglyph software'. http://z-graphix.com/anaglyph/zanag_en.htm.
- Belcher, K. & Moore, C. (2001), '3d Graphics Technology Changes Deepwater Installation Practices', *Sea Technology* 42(1), 49–51. ISSN 0093-3651.
- Belien, S. & Leenders, R. (1995), 'Comparison of Visualization Techniques and Packages (version 2.0)'. SARA Visualization Centre.
- Belien, S. & Leenders, R. (2002), 'An Immersive Virtual Reality Test Bed at noaa's Pacific Marine Environmental Laboratory'.
<http://www.noaanews.noaa.gov/magazine/stories/mag19.htm>.
- Blinn, J. (1990), 'Jim's Home Page - Notes on Visualization'.
<http://microsoft.com/blinn/VISUAL.HTM>.
- Bourke, P. (2002), 'Computer Generated Camera Projections and Lens Distortion'.
<http://astronomy.swin.edu.au/pbourke/projection/>.
- BP (2001), 'BP Centre for Visualization - University of Colorado at Boulder'.
http://www.colorado.edu/Research/bpVisCenter/Research_ImmersiveDrilling.htm.

REFERENCES

- Brodie, K., Gallop, J., Grant, A. J., J.Haswell, Hewitt, W. T., Larkin, S., Lilley, C. C., Morphet, H., Townsend, A., Wood, J. & Wright, H. (1995), *Review of Visualization Systems*, 2 edn.
- Brodie, K. W., Carpenter, L. A., Earnshaw, R. A., Gallop, J. R., Hubbard, R. J., Mumford, A. M., Osland, C. D. & Quarendon, P. (1992), *Scientific Visualization - Techniques and Applications*, Springer - Verlag, chapter 3.
- Cable-News-Network (2000), 'Kursk Submarine Raised'.
<http://www.cnn.com/2001/WORLD/europe/10/07/kursk.raising/>.
- Card, S. K., Mackinlay, J. D. & Shneiderman, B. (1999), *Readings in Information Visualization - Using Vision to Think*, 1 edn, Morgan Kaufmann Publishers. ISBN 1-55860-533-9.
- Chapman, P. M., Wills, D., Stevens, P. & Brookes, G. (1998), Seabed Visualization, in D. Ebert, H. Hagen & H. Rushmeier, eds, 'Proceedings IEEE Visualization '98', IEEE, pp. 479-481. ISBN 0-8186-9176-X.
- Chapman, P. M., Wills, D., Stevens, P. & Brookes, G. (1999a), 'Visualizing Underwater Environments using Multi-frequency Sonar', *IEEE Computer Graphics and Applications* 19(5), 61-65. ISSN 0272-1716 (invited paper).
- Chapman, P. M., Wills, D., Stevens, P. & Brookes, G. (1999b), Whole Field Modelling - Effective Real-time and Post-survey Visualization of Underwater Pipelines, in M. G. David Ebert & B. Hamann, eds, 'Proceedings IEEE Visualization '99', IEEE, pp. 445-448. ISBN 0-7803-5897-X.
- Chapman, P. M., Wills, D., Stevens, P. & Brookes, G. (2000), Real-time Visualization of the Clear-up of a Former U.S. Naval Base, in M. G. David Ebert & B. Hamann, eds, 'Proceedings IEEE Visualization 2000', IEEE, pp. 505-508. ISBN 0-7803-6478-3 (Awarded Best Conference Case Study Paper).
- Chapman, P. M., Wills, D., Stevens, P. & Brookes, G. (2001), 'Visualization Viewpoints: Real-time Visualization in the Offshore Industry', *IEEE Computer Graphics and Applications* 21(4), 6-10. ISSN 0272-1716 (invited paper) www.computer.org/cga/homepage/offshore.htm.
- Coastalo (2000), 'Coastal Oceanographics Company Website'.
<http://www.coastalo.com/dredgepack.htm>.
- Collins, B. (1993), *Animation and Scientific Visualization*, 1 edn, Academic Press, chapter 1 - Data Visualization - Has it all been seen before?, pp. 3-28. ISBN 0-12-227745-7.

REFERENCES

- Dang, A. (2001), 'The rise of nvidia'. <http://firingsquad.gamers.com/features/nvidiahistory/>.
- DataPath (2001), 'Realimation company website'. www.realimation.com.
- DeLora, M. (2000), *Games Programming Gems*, 1 edn, Charles River Media. Chapter 5.
- Duce, D. & Hopgood, F. (1990), 'Introduction to the Computer Graphics Reference Model', *BITS Newsletter No.4*.
- EarthVision (2002), 'Dynamic graphics company website'. www.dgi.com.
- Elumens (2001), 'The SPIClops API User Manual'. <http://www.elumens.com/>.
- Elumens (2002a), 'Elumens company website'. <http://www.elumens.com>.
- Elumens (2002b), 'Spherical projection of images api'. <http://www.elumens.com/technology/software.html>.
- ERMapper (2002), 'Er mapper company website'. <http://www.ermapper.com/>.
- ESRI (2002), 'Esri GIS and Mapping Software - company website'. <http://www.esri.com/>.
- Fakespace (2002), 'Fakespace company website'. <http://www.fakespacesystems.com/>.
- Fernando, R. & Kilgard, M. (2003), *The Cg Tutorial: The Definitive Guide to Programmable Real-time Graphics*, Aw Professional.
- Fish, J. & Carr, A. (1990), *Sound Underwater Images*, 1 edn, Lower Cape Publishing. ISBN 0936972149.
- Fish, J. & Carr, A. (2000), 'Sidescan Shipwreck Survey'. <http://www.edgetech.com/sonar>
- Foulser, D. (1995), 'Iris explorer: A framework for investigation', *Computer Graphics* 29(2), 13-16.
- Gallop, J. (1994), State of the Art in Visualization Software, in H. M. Hearnshaw & D. J. Unwin, eds, 'Visualization in Geographical Information Systems', Wiley Publishers, pp. 42-47. ISBN 0-47194435-01.
- Gardner, J., Butman, P., Mayer, L. & Clarke, J. (1998), 'Mapping U.S. Continental Shelves', *Sea Technology* pp. 10-17.
- Greene, N. (1986), Applications of World Projections, in 'Proceedings of Graphics Interface 1986', Wiley Publishers, pp. 108-116.
- Haber, R. B. & McNabb, D. A. (1990), 'Visualization Idioms: A Conceptual Model for Scientific Visualization Systems', *Visualization in Scientific Computing* pp. 74-93.

REFERENCES

- Hatcher, G. A. (1992), A Geographic Information System as a Data Management Tool for Seafloor Mapping, Msc thesis, University of Rhode Island, Narragansett, Rhode Island.
- Hatcher, G. A. (1999), Real-time GIS for Marine Applications, *in* D. Wright & D. Barlett, eds, 'Marine and Coastal Geographical Information Systems', pp. 137-147. ISBN 0-7484-0870-3.
- Iconetics (2002), '3dsmax homepage'. <http://www.3dmax.com/industry/index.cfm>.
- IEEE (2000), 'Ieee Visualization conference archive'. <http://vis.computer.org/>.
- Jeeninga, B. (1998), 'From Quality Control to Software Design', *Hydro International* 2(2), 65-67. ISSN 1385-4569.
- Kaplan, B. & Maxwell, J. (1994), Qualitative research methods for evaluating computer information systems, pp. 45-68.
- Lamport, L. (1986), *L^AT_EX: A Document Preparation System*, Addison-Wesley.
- Lee, K. (2001), *Inside 3D Studio Max 4*, 1 edn, New Riders Publishing. ISBN 0735710945.
- Lienhard, J. H. (2000), 'The Royal Oak'. <http://www.uh.edu/engines/epi292.htm>.
- Lillycrop, W., Irish, J. & Parson, L. (1997), 'Shoals System', *Sea Technology* 38(6), 17-25.
- Link, R. (2000), 'K-141 kursk'. <http://www.russialink.org.uk/kursk/>.
- Lipton, L. & Halnon, J. (1998), 'Interfacing Shutter-type Stereoscopic Hardware With Windows Workstations'. http://www.stereographics.com/html/crystaleyes_sdks.html.
- Lord, H. (1995), 'Improving the Application Development Process with Modular Visualization', *Computer Graphics* 29(2), 10-12.
- Ltd., S. (2002), 'Crystal eyes shutter glasses by stereo graphics ltd.'. <http://www.stereographics.com/>.
- Malone, T. (1983), How do People Organise their Desks, *in* 'Transactions on Office Information Systems', ACM, pp. 99-112.
- Manley, T. & Tallet, J. (1990), 'Volumetric Visualization: An Effective use of GIS Technology in the Field of Oceanography', *Oceanography* pp. 23-29.
- MathWorks (2002), 'The Mathworks, inc. Home Page.'. <http://www.mathworks.com/index.shtml>.
- McCormick, B. H., DeFanti, T. A. & Brown, M. D. (1987), 'Visualization in Scientific Computing', *Computer Graphics* 21(6), 1-14.

REFERENCES

- Microsoft (2002), 'Microsoft internet explorer'. <http://www.microsoft.com/windows/ie/default.asp>
- Myers, M. D. (1997), *Qualitative research in information systems*, pp. 241–242.
- NASA (2002), 'Nasa mars microrover telecommunications'.
<http://mars.jpl.nasa.gov/MPF/rovercom/rovcom.html>.
- Nautronix (2000), 'Nautronix Company Website'. www.nautronix.com.
- Netscape (2002), 'Netscape homepage'. <http://www.netscape.com/>.
- Numerics, V. (2001), 'Pvwave'. <http://www.vni.com/products/wave/>.
- nVidia (2002), 'Nvidia Company Website'. <http://www.nvidia.com/>.
- OPL (1998), *Dredgers of the World*, OPL Oilfield Publications.
- OPL (1999), *Remotely Operated Vehicles of the World*, OPL Oilfield Publications, p. 95.
- Orwell, G. (1954), *Nineteen Eighty-four*, Penguin Books. ISBN 014027877X.
- OSG (2003), 'Open scene graph website'. <http://www.openscenegraph.org>.
- Osland, C. (1992), Framework, in K. W. Brodlie, L. A. Carpenter, R. A. Earnshaw, J. Gallop, R. Hubbard, A. Mumford, C. Osland & P. Quarendon, eds, 'Scientific Visualization: Techniques and Applications', Springer Verlag, Berlin, pp. 15–35.
- Pratson, L. F. & Haxby, W. F. (1997), 'Panoramas of the Seafloor', *Scientific American* pp. 67–71. www.sciam.com/0697issue/0697pratson.html.
- Refsland, S., Ojika, T., DeFanti, T., Johnson, A., Leigh, J., Loeffler, C. & Tu, X. (1998), Virtual great barrier reef: A theoretical approach towards an evolving, interactive vr environment using a distributed dome and cave system., in J.-C. Heudin, ed., 'Proceedings of Virtual Worlds '98. Paris, France', Springer Verlag, Berlin, pp. 323–336.
- Rollings, A. (1999), *Game Architecture and Design*, 1 edn, Coriolis Group. ISBN 1576104257.
- Rosset, G. (2002), 'Augmented Reality Homepage'. <http://www.augmented-reality.org/>.
- Smedvig (2000), 'Roxar World Website'. www.smedtech.com.
- Smetak, E. & Caputo, J. (1997), 'Dynamic Runtime Objects: Building Applications Your Users Can Modify at Runtime', *Microsoft Systems Journal*.
- SMPTE (1993), 'Report of the Task Force on Digital Image Architecture', *SMPTE*. SMPTE Task Force Report.

REFERENCES

- Spence, R. (2001), *Information Visualization*, 1 edn, Addison Wesley, chapter 4 - Representation, pp. 52–69. ISBN 0-201-59626-1.
- Spyglass (2001), 'Company website'. <http://www.opentv.com/redirect.html>.
- SRD (1990), 'Training and Development Notes'.
- Stride, A. (1982), *Offshore Tidal Sands, Processes and Deposits*, Chapman and Hall, New York, pp. 46–48.
- SUT & BP (2001), 'The British Petroleum and Society for Underwater Technology Underwater Image Competition 2001'. <http://www.soc.soton.ac.uk/GDD/img2001/>.
- Swale (2002), 'The Richard Montgomery'. <http://www.swale-community.org/richard.htm>.
- Thirugnanasothy, N. (2001), 'What is uniras'. <http://www.brad.ac.uk/cc/documentation/uniras/>.
- TOR (2000), 'How the Kursk will be Raised'. <http://www.ticketsofrussia.ru/kursk>.
- Upton, C., Jr, T. F., Kamins, D., Laidlaw, D., Schlegel, D., Vroom, J., Gurwitz, R. & VanDam, A. (1989), 'The Application Visualization System: A Computational Environment for Scientific Visualization', *IEEE Computer Graphics and Applications* 9(4), 30–42. ISSN 0272-1716 (invited paper).
- Urick, R. J. (1975), *Principles of Underwater Sound*, McGraw-Hill, New York. ISBN 0932146627.
- VanDam, A., Forsberg, A., Laidlaw, D., LaViola, J. & Simpson, R. (2000), 'Immersive vr for Scientific Visualization', *Computer Graphics and Applications*.
- Voodoo (2002), 'Voodoo reference page'. <http://www.voodoofiles.com/3dfxhelp.asp>.
- Wallas, G. (1926), *The Art of Thought*, Jonathan Cape, London.
- Watt, A. (1994), *3D Computer Graphics*, 2 edn, Addison Wesley, chapter 5, pp. 132–136. ISBN 0-201-63186-5.
- White, D., Scribner, K. & Olafsen, E. (1999), *MFC Programming With Visual C++ 6 Unleashed*, Sams. ISBN 0672315572.
- Wills, G. (2001), 'The exploratory data visualizer'. <http://www.bell-labs.com/user/gwills/EDVguide/guide/guide.html>.
- Woo, M., Neider, J. & Davis, T. (1997), *OpenGL Programming Guide*, 2 edn, Addison Wesley, chapter 6, pp. 239–247. ISBN 0-201-46138-2.

REFERENCES

- Woods, A., Docherty, T. & Koch, R. (1994), Experiences of Using Stereoscopic Video with an Underwater Remotely Operated Vehicle, *in* 'Underwater Intervention', pp. 34-38.
- Wright, D. (1994), From Pattern to Process on the Deep Ocean Floor: A Geographic Information System Approach, Phd., University of California, Santa Barbara, California. (First ever Ph.D thesis in marine GIS.
- Wright, D. (1996), 'Rumblings on the ocean floor: Gis supports deep-sea research', *Geographical Information Systems* 6(1), 22-29.
- Wright, D. (1999), Down to the Sea in Ships: The Emergence of Marine gis, *in* D. Wright & D. Barlett, eds, 'Marine and Coastal Geographical Information Systems', pp. 1-10. ISBN 0-7484-0870-3.
- Young, M., Argiro, D. & Kubuca, S. (1995), 'Cantata: Visual programming environment for the khoros system', *Computer Graphics* 29(2), 22-24.